

NOTES:

- 1) PERFORMANCE IS PER CUSTOMER CONDITIONS AND SPECIFIC QUOTATION.
- 2) ALLOW 28" MINIMUM CLEARANCE ON ALL SIDES OF CHILLER FOR PROPER AIR FLOW AND MAINTENANCE.
- 2) WEIGHT: TAE 081: 682 LBS

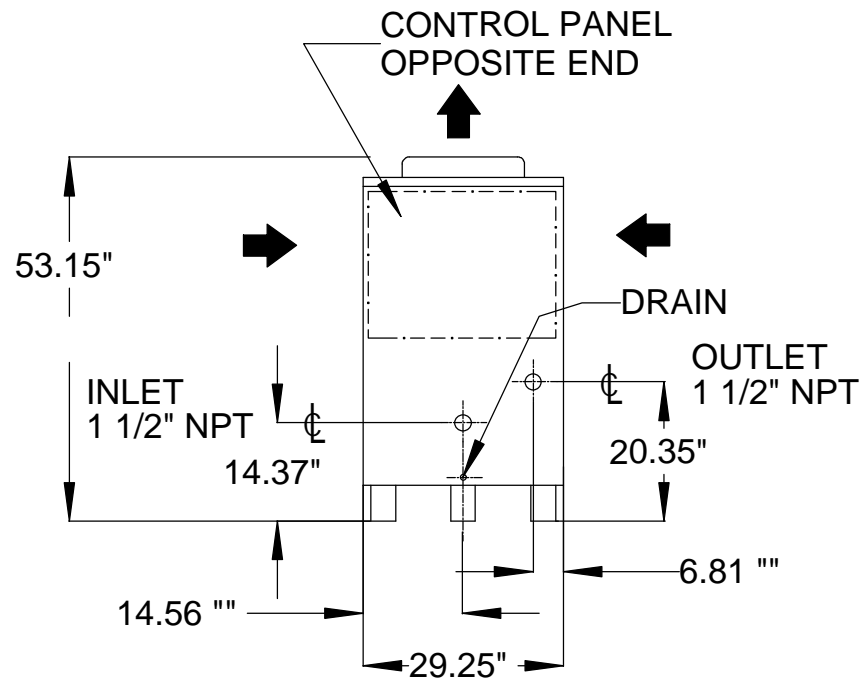
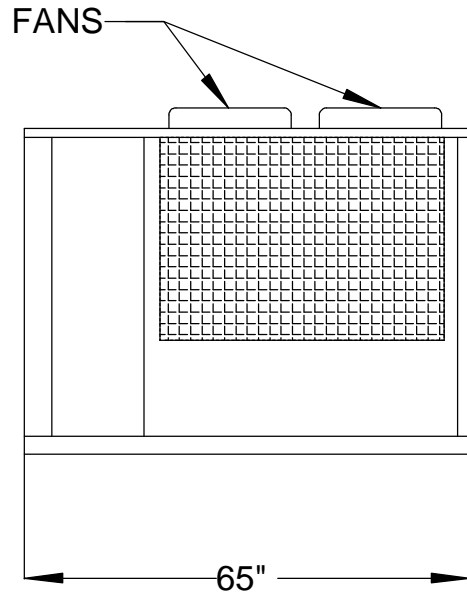

★★★ **GENERAL AIR PRODUCTS**

TITLE
AIR COOLED CHILLER
MODELS: TAE081

SIZE A	DRAWN BY: DPH	DATE: 07/21/00	REV 0
SCALE NTS	DWG NO G-200109	SHEET 1 OF 1	