

NOTES:

- 1) PERFORMANCE IS PER CUSTOMER CONDITIONS AND SPECIFIC QUOTATION.
- 2) ALLOW 28" MINIMUM CLEARANCE ON ALL SIDES OF CHILLER FOR PROPER AIR FLOW AND MAINTENANCE.
- 2) WEIGHT: TAE101: 755 LBS.
TAE121: 803 LBS.
- 3) BSP TO NPT THREAD ADAPTERS ARE SHIPPED LOOSE. INSTALL ADAPTERS AT SITE IF REQUIRED.

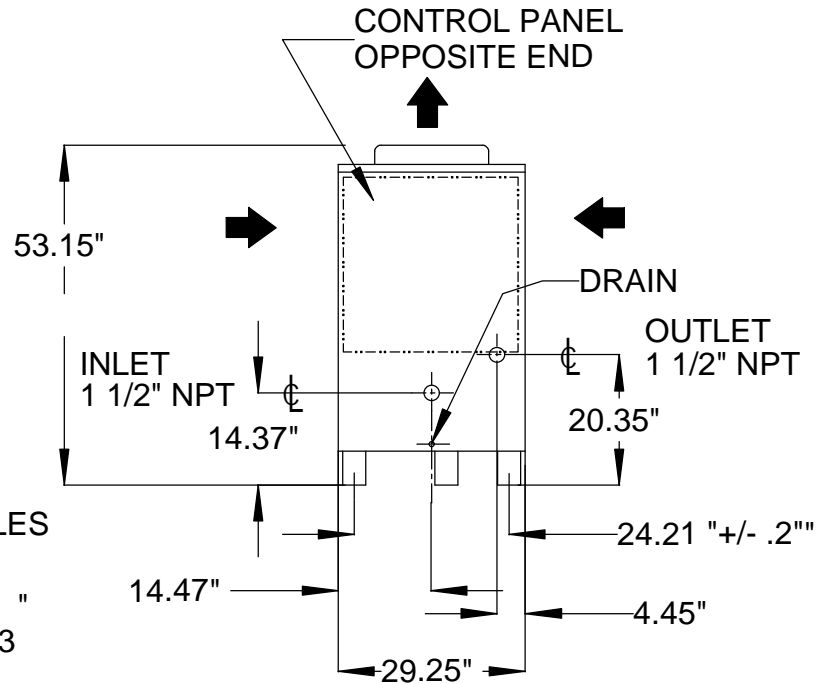

REV 1, 9/20/00; ADDED BSP TO NPT ADAPTERS

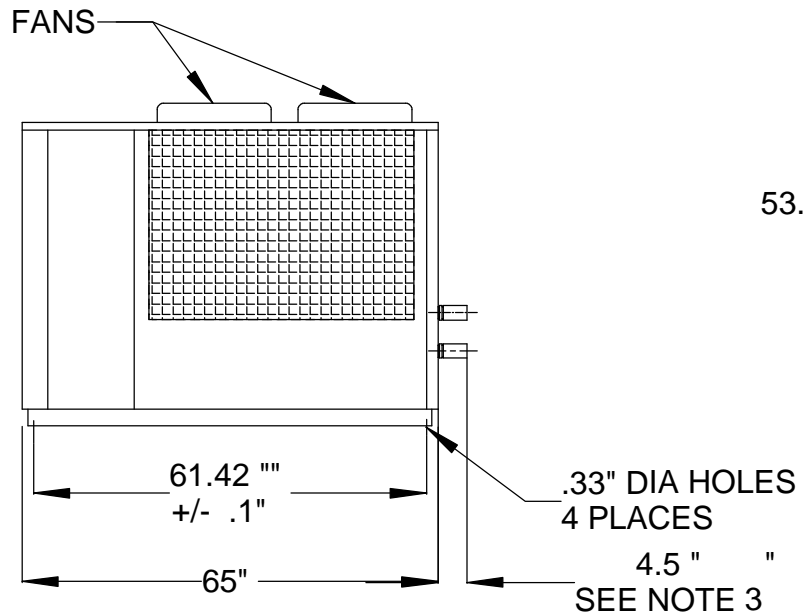

GENERAL AIR PRODUCTS

TITLE

AIR COOLED CHILLER

MODELS: TAE101 AND TAE121

SIZE

DRAWN BY:

DPH

DATE:

06/14/00

REV

1

SCALE

NTS

DWG NO

G-200059

SHEET

1 OF 1