

OIL-LESS COMPRESSOR THREE PHASE WIRING INSTRUCTIONS



GENERAL

AIR PRODUCTS, INC.

NOTE: MOST MOTORS ARE MULTIPLE VOLTAGE. CHECK NAMEPLATE AND VERIFY CORRECT INTERNAL CONNECTIONS FOR VOLTAGE BEING SUPPLIED TO UNIT.

FEEDER WIRE SIZE MUST BE CAPABLE OF CARRYING CURRENT LOAD OF COMPRESSOR AT MAXIMUM PRESSURE.

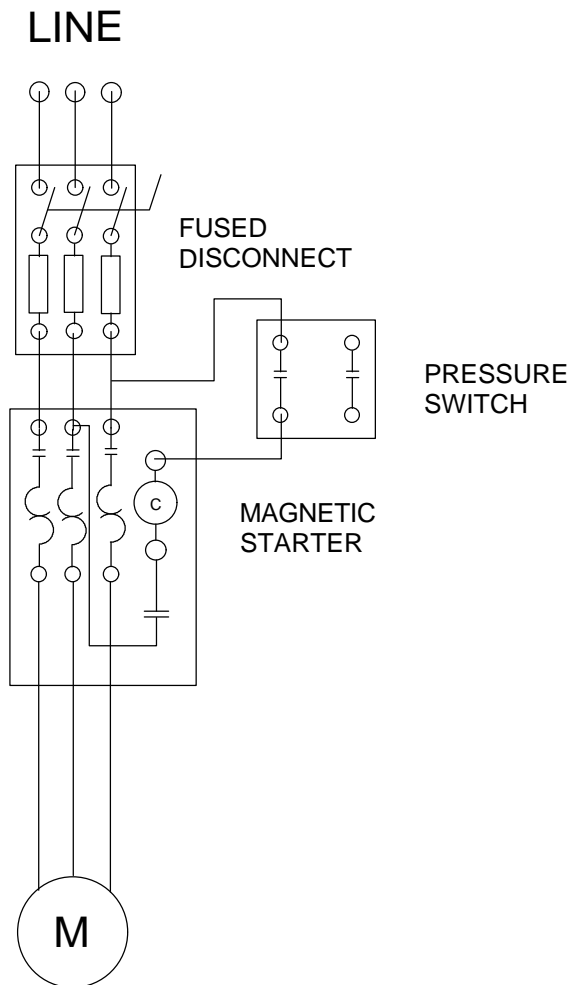

THREE PHASE

OTHER WIRING VARIATIONS POSSIBLE DEPENDING ON LOCAL CODES

PRESSURE SWITCH TO CONTROL PILOT CIRCUIT

CONSULT MANUFACTURERS INSTRUCTIONS ON STARTER FOR VARIATIONS ON DIAGRAM SHOWN