

## OIL-LESS COMPRESSOR INSTRUCTION SHEETS

### NOTE

This compressor is intended for installation indoors for use on dry sprinkler systems in accordance with the Standard for Installation of Sprinkler Systems, NFPA 13 and the National Electrical Code, NFPA 70. The compressor should be sized to restore and maintain the air pressure in the sprinkler system in accordance with the requirements in NFPA 13.

### DANGER

This compressor is not equipped and should NOT be used "as is" to supply breathing quality air.

### WARNING

Motors, electrical equipment and controls can cause electrical arcs that will ignite a flammable gas or vapor. Never operate or repair in or near a flammable gas or vapor. Never store flammable liquids or gases near the compressor.

### WARNING

These compressors are suitable for pumping only atmospheric air. As defined in Compressed Gas Association Pamphlet G-7, page 3, atmospheric air is a mixture of elements and compounds where nitrogen and oxygen comprise more than 99% with all other trace gases comprising less than 1%. **DO NOT USE THIS COMPRESSOR IN CONTAMINATED ENVIRONMENTS OR FOR PUMPING MIXTURES OTHER THAN ATMOSPHERIC AIR**

### WARNING

Compressed air contains liquid water and is saturated with water vapor, which can freeze. Do not connect compressor outlet to freezer rooms or systems exposed to temperatures below freezing. If system connects to a freezer room or area exposed to freezing temperatures, a Dry Air Pac™ should be used.

### Receiving

Your compressor is inspected at the factory and packaged to protect against shipping damage. When the compressor is unpacked, inspect for damage or missing parts. All claims should be settled directly with the freight company.

**WARNING: Do not operate this compressor if damaged during shipment, handling, or use. Damage may result in bursting and cause injury or property damage.**

### Location

**NOTE: Do not connect compressor intake to freezer room. – CALL 1-800-345-8207.**

Locate the compressor in a clean, well-ventilated area where the air is relatively cool, clean, and dry. A 110°F (35 C) maximum and 40°F (4.5 C) minimum temperature for surrounding and inlet air are recommended. Provide at least 12 to 18 inches from any wall or other obstruction that will interfere with airflow through the motor's fan built into the motor. Blocking airflow through the fan may cause the compressor to over heat. Do not place the compressor in an area of excessive heat, such as near a boiler.

### Mounting

Riser mounted compressors may be mounted to a firm level floor, wall or system riser. A mounting bracket

and straps are provided. Tank mounted compressors should be bolted to the floor using the bolt holes provided in the tank legs. Always shim the unit level before bolting it to the floor. Vibration isolators (P/N KVP4X4) are recommended. When using isolator pads, do not draw bolts tight. Allow the pad to absorb vibrations. When isolators are used, a flexible hose (P/N P1202MP) should be installed between the compressor and service piping.

### Lubrication

**NOTE:** This compressor is designed for non-lubricated service. Bearings are permanently lubricated. Do not lubricate any part of the compressor or motor.

### Piping (reference "Installation Instructions" drawings)

### WARNING

Compressed air contains liquid water and is saturated with water vapor, which can freeze. Do not connect compressor outlet to freezer rooms or systems exposed to temperatures below freezing. If system connects to a freezer room or area exposed to freezing temperatures, a Dry Air Pac™ should be used.

Piping between the compressor, accessory items and the sprinkler system should be at least ¾" internal

# GENERAL AIR PRODUCTS, INC.

diameter to minimize pressure drop from the compressor to system. Larger pipe size may be required by code and may be substituted with no adverse effects. Smaller line size must not be used and will restrict the compressor flow, lowering capacity and causing the compressor/motor to work harder, which shortens compressor/motor life. All piping connected to the compressor must be fully supported and not transfer any loads to the compressor.

If an AMD-1 is used, allow sufficient distance between the compressor and AMD-1 to ensure that the maximum temperature at the AMD-1 is 200°F or less.

**For riser mounted units only, when an AMD is used, relocate the sensing line for the pressure switch to the system side of the system check valve and install a relief valve, P/N VR3P25080 between the compressor outlet and AMD.**

All oil-less compressors include a relief valve. For riser mounted models, the relief valve is installed on the compressor outlet. For tank mounted models, an ASME Code relief valve is mounted on the compressor's tank. This valve will open at a preset value above the pressure switch setting to prevent excess tank pressure in the event of switch failure.

**WARNING:** Do not attempt to change the safety relief valve setting.

A manual drain is provided on the bottom of each tank mounted compressor. Moisture accumulated in the tank, must be drained weekly. An automatic drain, P/N DVA-2T, is recommended in areas of high humidity.

The compressor outlet piping should contain an accessible drain. As a minimum a manual drain may be used, but an automatic drain is recommended to remove excess water.

**NOTE:** Accumulation of condensed water in a system causes corrosion of components and reduces system capacity.

**NOTICE:** Warranty is void if a separate check valve is not installed to prevent water back flow.

Wiring (reference "Wiring Instructions" drawings)

## WARNING

Have a qualified electrician wire the compressor to ensure that the supply line has the same characteristics (voltage, frequency and phasing) as the motor. Wiring must comply with all local and national codes.

## CAUTION

Inadequate wiring size can cause insufficient voltage at the compressor during start-up. Overheating and damage to the motor and controls may result

The supply wire must be of adequate size and no other equipment should be connected to the same line. The table below lists the recommended wire size for each model, based on a 100' run. Consult factory for longer runs.

MINIMUM RECOMMENDED WIRE SIZE		
MODEL	1 PHASE	3 PHASE
OL11016**	12	N/A
OL21533**	10	N/A
OL33550**	8	12
OL435V75**	8	12
OL610V100**	8	12
OL900V100**	8	12
OL1200V200**	10	10

The motors supplied are multiple voltage motors. A label on the pressure switch cover indicates the voltage the motor is pre-wired for. If the supply voltage, on site, is different from the voltage indicated on this label, change the internal motor voltage connections to match the supply voltage. To change internal voltage connections, remove the cover plate located on the rear or side of the motor and reconnect the wire leads as shown on the motor's wiring diagram.

On all three phase and  $\frac{1}{2}$ Hp and  $\frac{3}{4}$ Hp single phase models, an arrow on the motor indicates the direction of rotation of the compressor. If the compressor rotates in the opposite direction, reverse the rotation of the motor. On single phase units, reverse motor rotation by interchanging the red and black motor leads. Interchanging any two incoming supply wires reverses rotation of three phase motors.

**NOTICE:** Single-phase oil-less compressors can not be operated at 208V. Operating the compressor at 208V voids the warranty.

**NOTICE:** Single-phase motors include internal thermal overload protection, which has an automatic reset device.

**WARNING:** Disconnect electrical power before servicing to disable reset devices. Thermal protection can automatically start the motor when the protector resets.

On single phase models, the motor is pre-wired to the pressure switch provided, which controls starting (cut in pressure) and stopping (cut out pressure) of the motor. The pressure switch is factory set at 27 psig cut in and 40 psig cut out. Consult General Air Products before adjusting the pressure switch.

# **GENERAL AIR PRODUCTS, INC.**

On three-phase compressors, the motor is not pre-wired to the pressure switch. Refer to the three phase wiring instruction drawing for recommended wiring.

A magnetic starter is required, for all models, to protect the motor from overload conditions. Refer to the proper wiring instruction drawing for recommended wiring to a starter.

**NOTE:** Failure to use the pressure switch may result in overpressure of the compressor or other components in the system. Overpressure of the compressor may result in blown head gaskets or other damage.

**NOTE:** Do not run two phases of a three phase supply through the pressure switch. Serious damage can result.

## Maintenance Instructions

### **WARNING**

DISCONNECT, TAG AND LOCK OUT POWER SOURCE THEN RELEASE ALL PRESSURE FROM THE SYSTEM BEFORE ATTEMPTING TO INSTALL, SERVICE, RELOCATE OR PERFORM ANY SERVICE.

The following instructions are based on NORMAL operation. If the compressor is in an excessively dusty area, increase frequency of maintenance checks.

#### WEEKLY

- Drain condensate from receiver and traps.
- Check for unusual noise or vibration.
- Clean air filters. – **NOTE: Do not clean filters with petroleum based products.**
- Clean all external parts of the compressor and motor.

#### MONTHLY

- Manually test safety relief valve.
- Inspect air system for leaks and tighten nuts and cap screws as required.

#### QUARTERLY

- Change filters.

## Limited Warranty

General Air Products, Inc. warrants its products to be free of defects in material and workmanship under normal use and service for 12 months from date of purchase. Our warranty applies only when such defective parts are returned to us, or our Authorized Service Depot, transportation prepaid, and subject to our inspection and approval. Liability is limited to repair or replacement of material found defective, free of charge, FOB our plant. Unauthorized repairs or replacements will not be subject to factory warranty. This warranty is in lieu of all other warranties, expressed or implied.

## General Notes

- 1) Warranty can be voided if modifications or adjustments are made without consultation and approval; from factory personnel.
- 2) If there are any questions regarding installation or operation of this compressor, please call the 800 number listed below.



**GENERAL AIR PRODUCTS, INC.**

**MANUFACTURERS • ENGINEERS • DISTRIBUTORS**

604 Jeffers Circle, Exton, PA 19341 • P.O. Box 1387, West Chester, PA 19380-0028

For Assistance Please Call 1-800 345-8207  
Please keep these instructions for future reference.

OILLESSINST  
REV 02/10/03

# GENERAL AIR PRODUCTS, INC.

## Trouble Shooting Guide

Symptom	Possible Cause(s)	Corrective Action
Motor hums and runs slowly or not at all	<ol style="list-style-type: none"> <li>1. Low voltage or no voltage</li> <li>2. Shorted or open motor winding</li> <li>3. Defective check valve</li> <li>4. Defective pressure switch – contacts will not close</li> </ol>	<ol style="list-style-type: none"> <li>1. Check voltage during attempt to start. Voltage must be within +/-10% of nominal voltage to start motor. Increase wire size if necessary to lower voltage drop.</li> <li>2. Replace motor</li> <li>3. Replace check valve</li> <li>4. Repair or replace pressure switch</li> </ol>
Reset mechanism cuts out repeatedly or fuses blow repeatedly	<ol style="list-style-type: none"> <li>1. Insufficient voltage to motor</li> <li>2. Pressure switch set too high</li> <li>3. Wrong fuse size</li> <li>4. Piping too restrictive</li> <li>5. Defective motor</li> </ol>	<ol style="list-style-type: none"> <li>1. Check voltage during attempt to start. Voltage must be within +/-10% of nominal voltage to start motor. Increase wire size if necessary to lower voltage drop.</li> <li>2. Consult factory, adjust or replace</li> <li>3. Be sure fuses and heaters are rated properly</li> <li>4. Add receiver vessel or increase pipe volume after compressor.</li> <li>5. Replace motor</li> </ol>
Unit short cycles repeatedly	<ol style="list-style-type: none"> <li>1. Piping too restrictive</li> <li>2. Leak in line before system check valve</li> </ol>	<ol style="list-style-type: none"> <li>1. Add receiver vessel or increase pipe volume after compressor.</li> <li>2. Repair leaks(s)</li> </ol>
Compressor Overheating	<ol style="list-style-type: none"> <li>1. Dirty intake filter</li> <li>2. Wrong motor rotation</li> <li>3. Air flow to fan on flywheel blocked</li> </ol>	<ol style="list-style-type: none"> <li>1. Clean intake filter</li> <li>2. Correct rotation</li> <li>3. Clear air flow to fan or relocate unit</li> </ol>
Excessive noise in operation	<ol style="list-style-type: none"> <li>1. Damaged bearings</li> <li>2. Worn piston rings or skirts</li> <li>3. Broken valves</li> <li>4. Loose blower wheel</li> <li>5. Damaged Blower baffle</li> </ol>	<ol style="list-style-type: none"> <li>1. Contact General Air Products, Inc. Service Department. 1-(800)345-8207</li> </ol>
System pressure builds slowly	<ol style="list-style-type: none"> <li>1. Compressor sized incorrectly</li> <li>2. Leaks or restrictions in piping</li> <li>3. Dirty intake filter</li> <li>4. Blown head gasket</li> </ol>	<ol style="list-style-type: none"> <li>1. Check system size and compressor sizing</li> <li>2. Correct leaks and remove restrictions</li> <li>3. Clean intake filter</li> <li>4. Replace head gasket</li> </ol>

For Assistance Please Call 1-800 345-8207  
Please keep these instructions for future reference.

# RISER MOUNT OIL-LESS COMPRESSORS INSTALLATION INSTRUCTIONS



ALL PIPING AND WIRING TO BE IN ACCORDANCE WITH APPLICABLE STATE, LOCAL AND NATIONAL CODES & SHOULD BE APPROVED BY AHJ

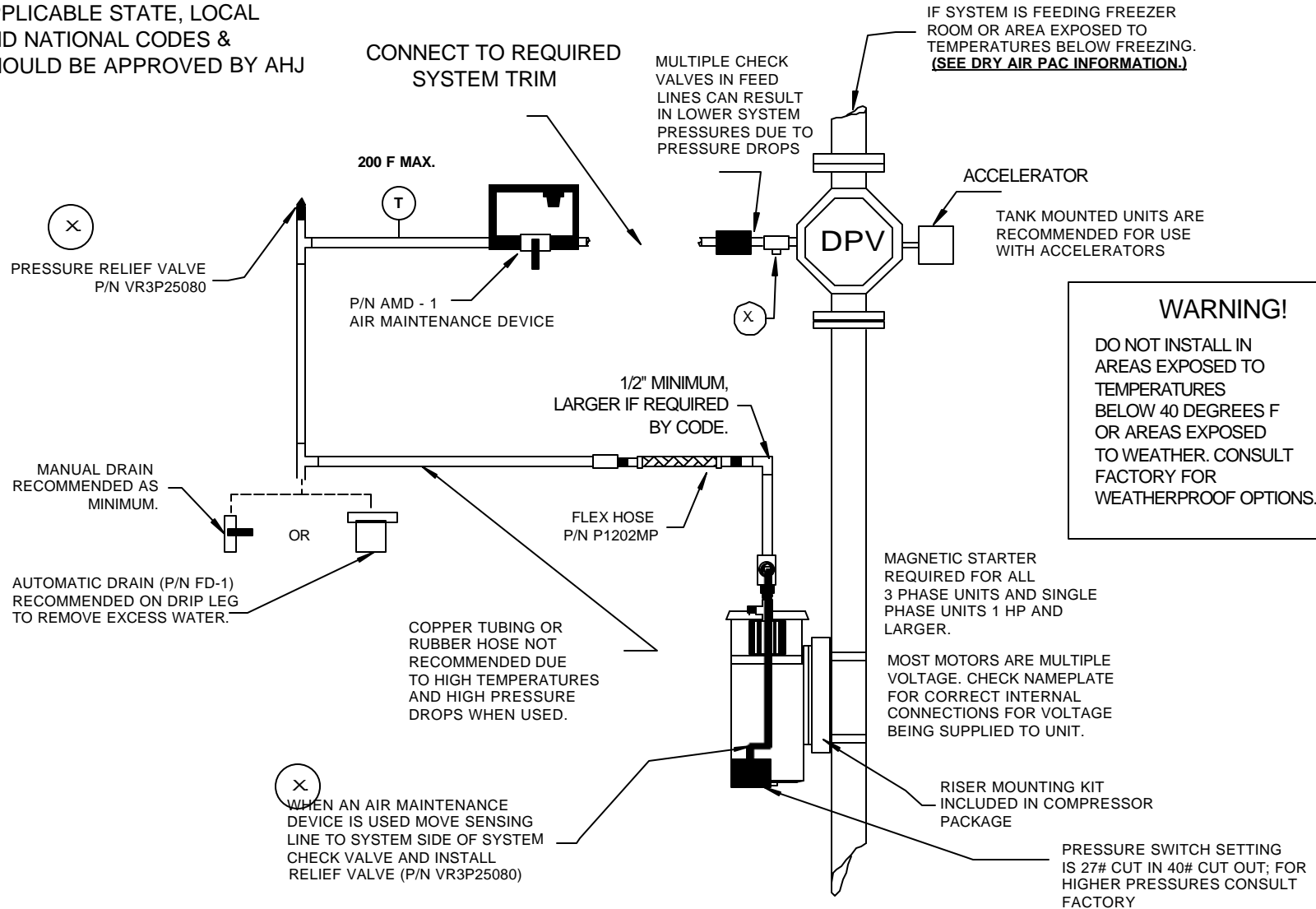

PART NUMBERS LISTED ARE FOR ACCESSORY ITEMS RECOMMENDED FOR COMPLETE INSTALLATION - CONSULT YOUR LOCAL DISTRIBUTOR FOR AVAILABILITY

# TANK MOUNTED OIL-LESS COMPRESSORS INSTALLATION INSTRUCTIONS



ALL PIPING AND WIRING TO BE IN ACCORDANCE WITH APPLICABLE STATE, LOCAL AND NATIONAL CODES & SHOULD BE APPROVED BY AHJ

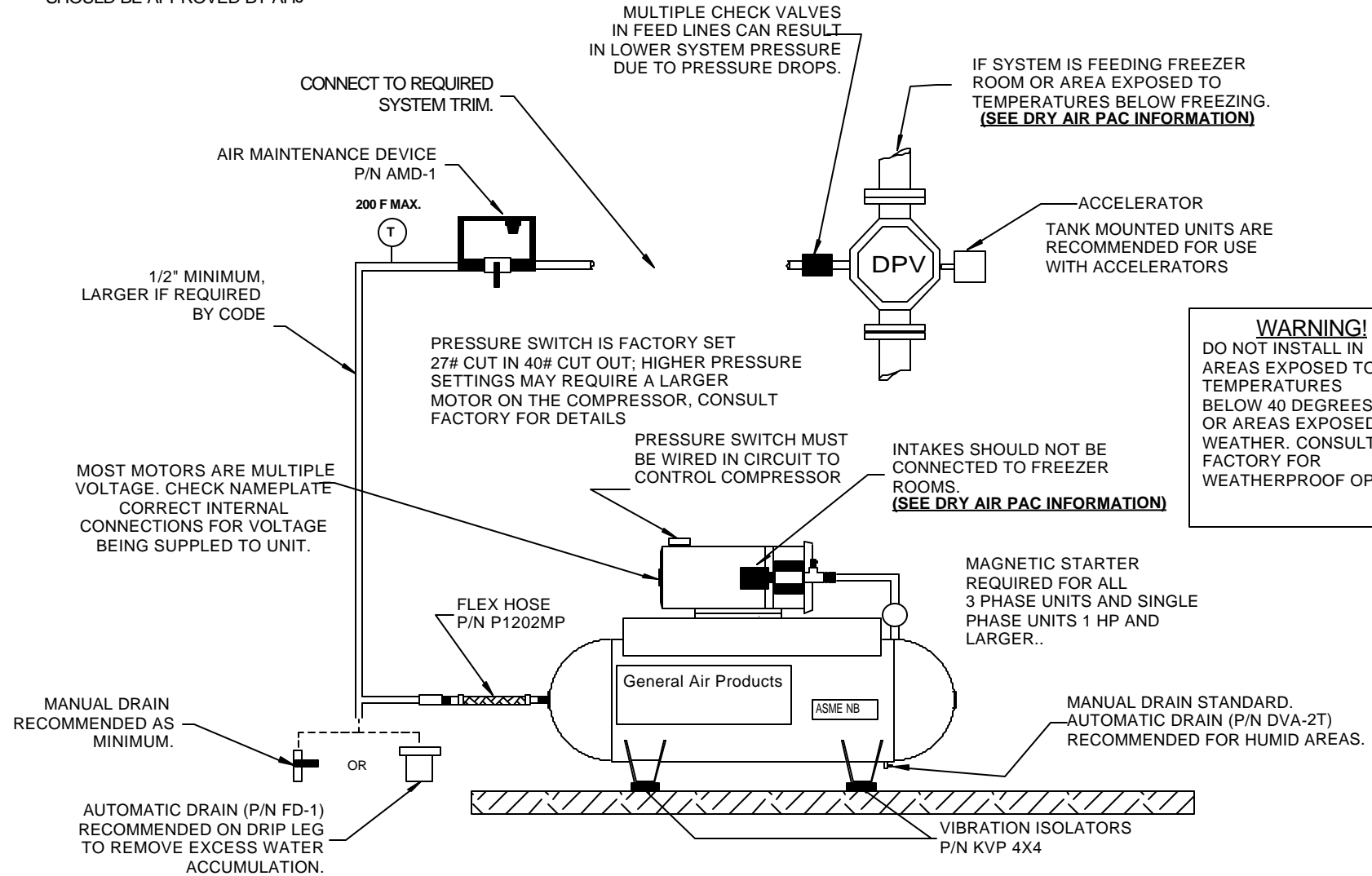

PART NUMBERS LISTED ARE FOR ACCESSORY ITEMS RECOMMENDED FOR COMPLETE INSTALLATION - CONSULT YOUR LOCAL DISTRIBUTOR FOR AVAILABILITY

TNKOLIS (05/03/99)

# OIL-LESS COMPRESSOR SINGLE PHASE WIRING INSTRUCTIONS

NOTE: MOST MOTORS ARE MULTIPLE VOLTAGE. CHECK NAMEPLATE AND VERIFY CORRECT INTERNAL CONNECTIONS FOR VOLTAGE BEING SUPPLIED TO UNIT.

FEEDER WIRE SIZE MUST BE CAPABLE OF CARRYING CURRENT LOAD OF COMPRESSOR AT MAXIMUM PRESSURE.

**FIG 1**

SINGLE PHASE BUILT IN OVERLOAD PROTECTION. (NOT TO EXCEED 3/4 HP).

FOR 115V ELIMINATE FUSE IN GROUND LEG.

PRESSURE SWITCH HP RATING MUST NOT BE EXCEEDED.

OTHER WIRING VARIATIONS POSSIBLE DEPENDING ON LOCAL CODES.

PRESSURE SWITCH

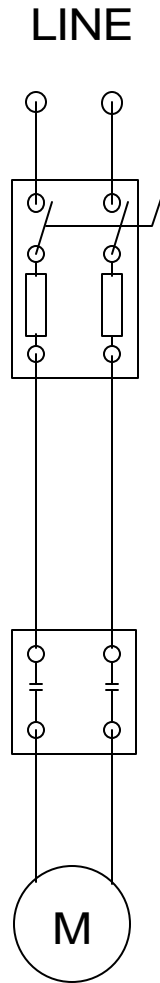

**FIG 1**

**FIG 2**

SINGLE PHASE WITH OR WITHOUT OVERLOAD PROTECTION.

FOR 115V ELIMINATE FUSE IN GROUND LEG.

PRESSURE SWITCH TO CONTROL PILOT CIRCUIT.

OTHER WIRING VARIATIONS POSSIBLE DEPENDING ON LOCAL CODES.

CONSULT MANUFACTURER'S INSTRUCTIONS ON STARTER FOR VARIATIONS ON DIAGRAM SHOWN.

PRESSURE SWITCH

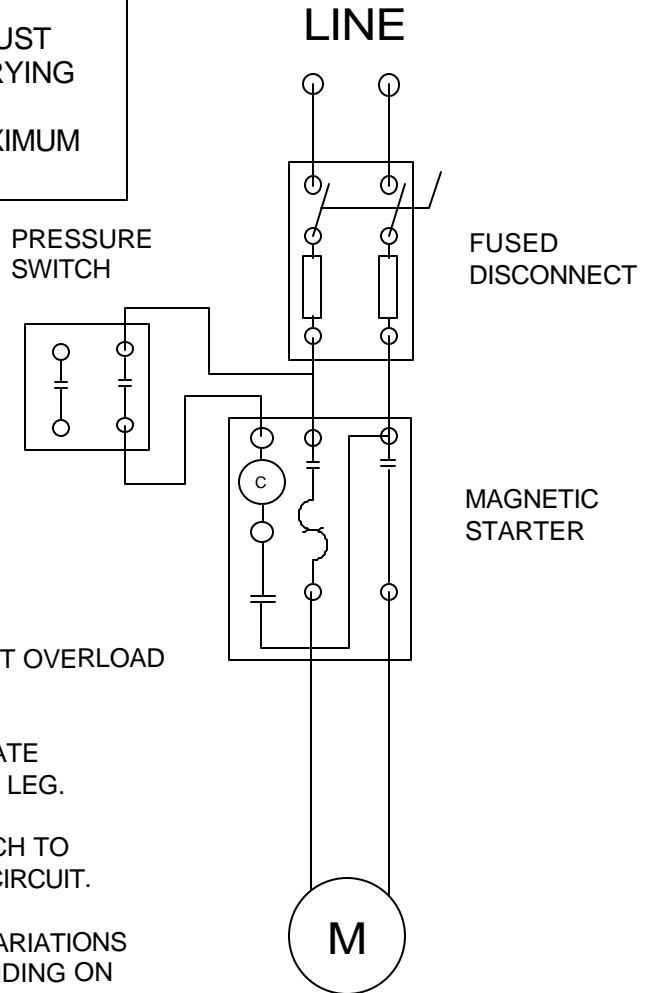

**FIG 2**

# OIL-LESS COMPRESSOR THREE PHASE WIRING INSTRUCTIONS



NOTE: MOST MOTORS ARE MULTIPLE VOLTAGE. CHECK NAMEPLATE AND VERIFY CORRECT INTERNAL CONNECTIONS FOR VOLTAGE BEING SUPPLIED TO UNIT.

FEEDER WIRE SIZE MUST BE CAPABLE OF CARRYING CURRENT LOAD OF COMPRESSOR AT MAXIMUM PRESSURE.

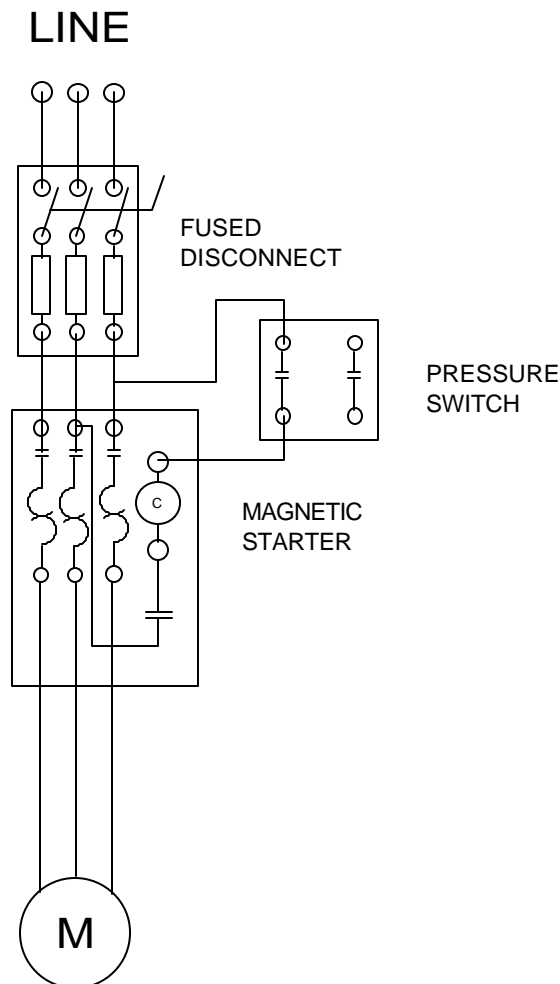

THREE PHASE

OTHER WIRING VARIATIONS POSSIBLE DEPENDING ON LOCAL CODES

PRESSURE SWITCH TO CONTROL PILOT CIRCUIT

CONSULT MANUFACTURERS INSTRUCTIONS ON STARTER FOR VARIATIONS ON DIAGRAM SHOWN