

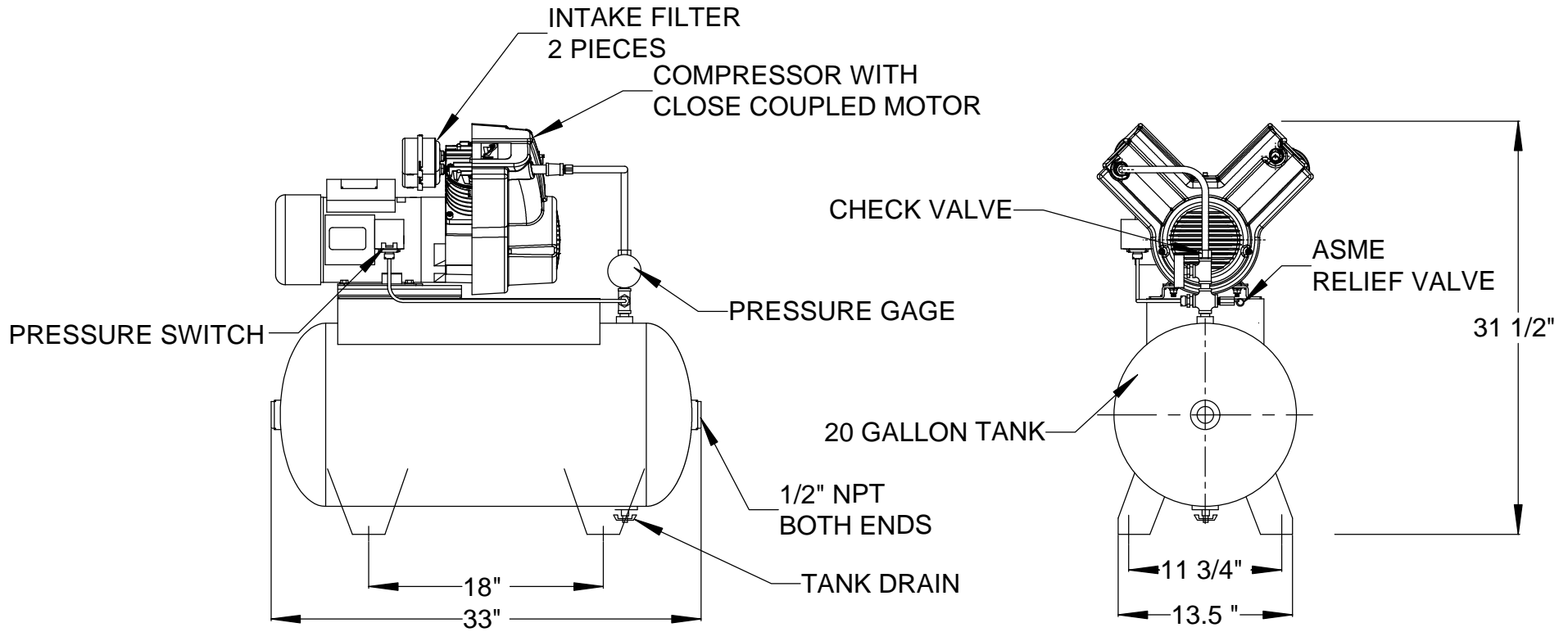

NOTES:

- 1) THIS DRAWING REPRESENTS MULTIPLE ASSEMBLIES.  
SEE TABLE FOR MODELS REPRESENTED. SINGLE PHASE ASSEMBLY IS SHOWN.
- 2) REFERENCE INDIVIDUAL PARTS LISTS FOR COMPONENT PART NUMBERS.
- 3) REFERENCE INSTRUCTION MANUAL FOR INSTALLATION AND WIRING RECOMMENDATIONS.



MODEL	VOLTAGE
OL1200V200ACT	230V/60HZ/1PH
OL1200V200ACT-50	230V/50H/1PH
OL1200V200BCT	230/460V/60HZ/3PH

OL1200V200ACT.TCW

				 <b>GENERAL AIR PRODUCTS</b>	
				<b>TITLE GENERAL ARRANGEMENT 2 HORSEPOWER TANK MOUNTED OIL-LESS COMPRESSORS</b>	
SIZE A	DRAWN BY: DPH	DATE: 07/23/03	REV 0		
SCALE NTS	DWG NO G-203014	SHEET 1 OF 1			