

4 | 3 | 2 | 1

REVISIONS				
ZONE	REV	DESCRIPTION	DATE	APPROVED
2		REDRAWN TO AUTOCAD	03-30-08	

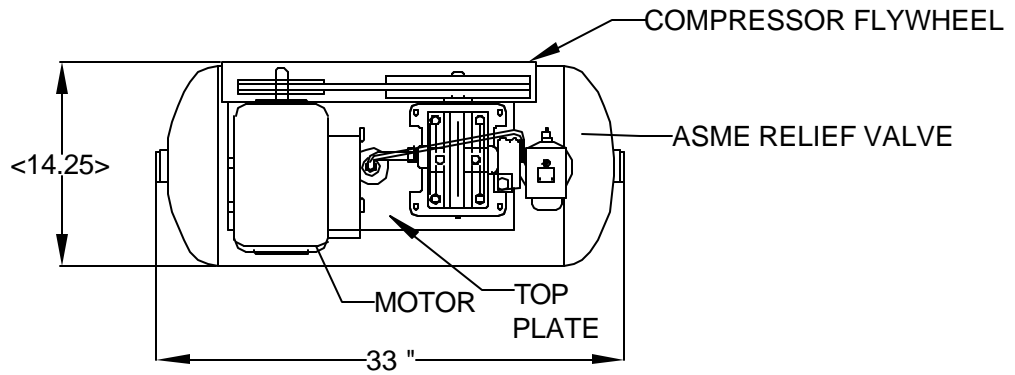

- NOTES:
- 1) THIS DRAWING REPRESENTS MULTIPLE ASSEMBLIES. SEE TABLE BELOW FOR MODELS REPRESENTED.
 - 2) REFERENCE INDIVIDUAL PARTS LISTS FOR COMPONENT PART NUMBERS.
 - 3) REFERENCE INSTRUCTION MANUAL FOR INSTALLATION AND WIRING RECOMMENDATIONS.

MODEL NUMBER	VOLTAGE
LT1220200A	115/230V/60HZ/1PH
LT1220200A-50	110/220V/50HZ/1PH
LT1220200B	230/460V/60HZ/3PH
LT1220200B-50	190/380//50HZ/3PH

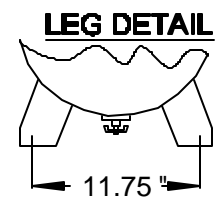
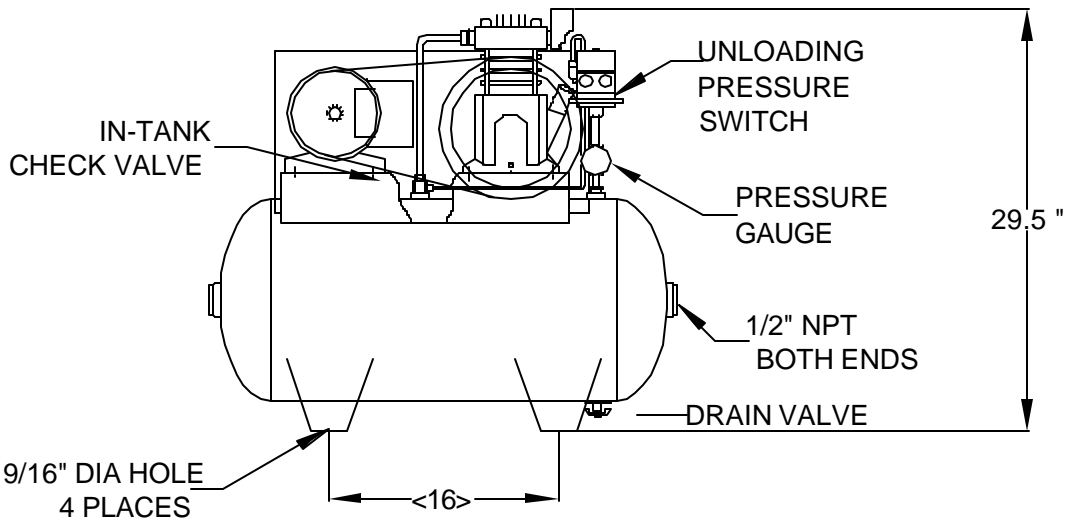

COMPRESSOR LUBRICATED TANK MOUNT LT122000.DWG

UNLESS OTHERWISE SPECIFIED
DIMENSIONS ARE IN INCHES
TOLERANCES ARE:
FRACTIONS DECIMALS ANGLES
 $\pm 1/4$.XX ±.13 ±1/2°

GENERAL
AIR PRODUCTS

APPROVALS	DATE	GENERAL ARRANGEMENT 2 HORSE POWER TANK MOUNTED LUBRICATED COMPRESSORS
DRAWN		
CHECKED		
DATE		

DWG NO. **G-200007** REV **2**

4 | 3 | 2 | 1