

NOTES:

- 1) THIS DRAWING REPRESENTS MULTIPLE ASSEMBLIES. SEE TABLE BELOW FOR MODELS REPRESENTED.
- 2) REFERENCE INDIVIDUAL PARTS LISTS FOR COMPONENT PART NUMBERS.
- 3) REFERENCE INSTRUCTION MANUAL FOR INSTALLATION AND WIRING RECOMMENDATIONS.

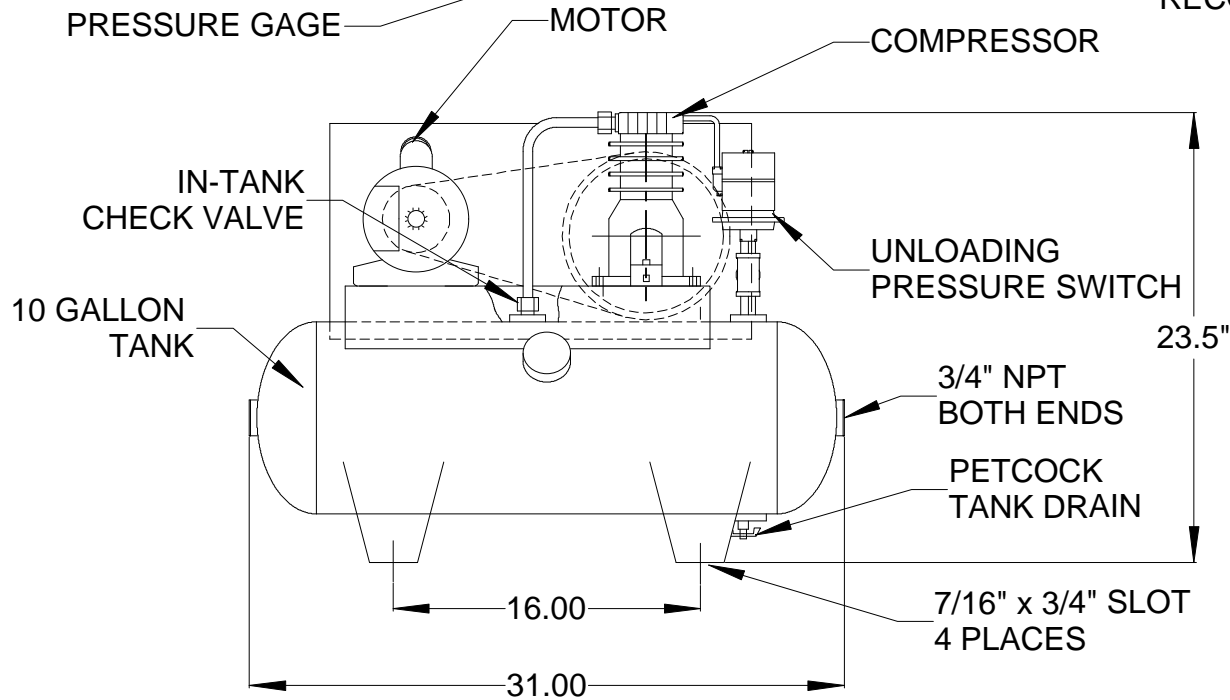

MODEL	VOLTAGE
LT29050A	110/230V/60HZ/1PH
LT29050A-50	110/220V/50HZ/1PH
LT29050B	230/460/60HZ/3PH
LT29050B-50	380V/50HZ/3PH

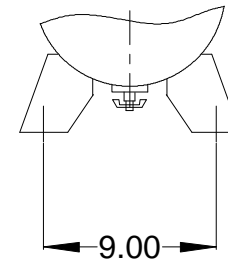

★★★ **GENERAL AIR PRODUCTS**

TITLE **GENERAL ARRANGEMENT
1/2 HORSEPOWER TANK MOUNTED
LUBRICATED COMPRESSOR**

SIZE A	DRAWN BY: DPH	DATE: 08/07/00	REV 0
SCALE NTS	DWG NO. G-200082	SHEET 1 OF 1	