

- NOTES:
- (1) THIS DRAWING REPRESENTS MULTIPLE ASSEMBLIES. SEE TABLE BELOW FOR MODLES REPESENTED.
 - (2) REFERENCE INDIVIDUAL PARTS LISTS FOR COMPLETE PART NUMBERS.
 - (3) REFERENCE INSTRUCTIONS MANUAL FOR INSTALLATION AND WIRING RECOMMENDATIONS.

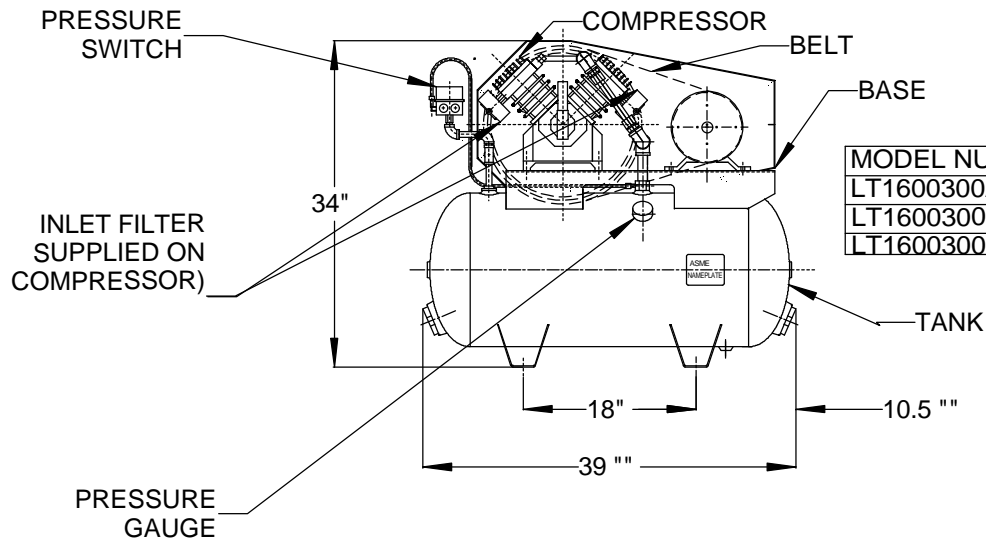

MODEL NUMBER	VOLTAGE
LT1600300A	208-230V/60HZ/1PH
LT1600300B	208-230/460V/60HZ/3PH
LT1600300B-50	208-230V/50HZ/3PH

SIZE A	DRAWN BY: JNS	DATE: 08/09/2000	REV 0
SCALE NTS	DWG NO G200089	SHEET 1 OF 1	