

REVISIONS				
ZONE	REV	DESCRIPTION	DATE	APPROVED
	2	REDRAWN TO AUTOCAD	09-24-09	

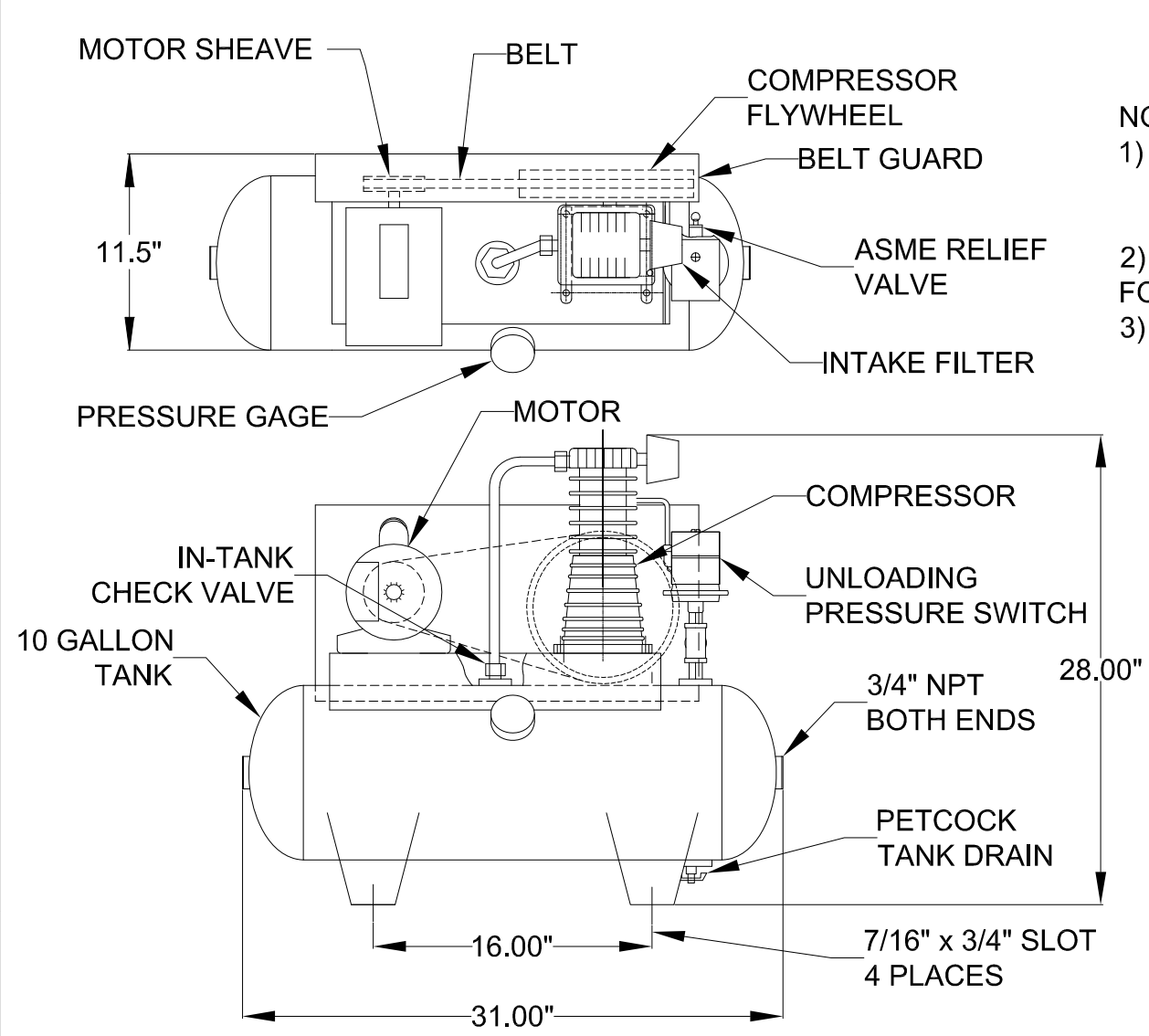

NOTES:

- 1) THIS DRAWING REPRESENTS MULTIPLE ASSEMBLIES. SEE TABLE BELOW FOR MODELS REPRESENTED.
- 2) REFERENCE INDIVIDUAL PARTS LISTS FOR COMPONENT PART NUMBERS.
- 3) REFERENCE INSTRUCTION MANUAL FOR INSTALLATION AND WIRING RECOMMENDATIONS.

MODEL	VOLTAGE
LT29050A	115/208-230V/60HZ/1PH
LT29050-50	110/220V/50HZ/1PH
LT29050B	230/460V/60HZ/3PH
LT29050B-50	190/380V/50HZ/3PH

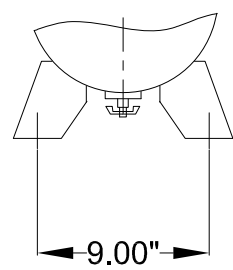

APPROVALS	DATE	TITLE
DRAWN EJR	09-24-09	GENERAL ARRANGEMENT 1/2 HORSEPOWER TANK MOUNTED LUBRICATED COMPRESSOR
CHECKED DPH	09-24-09	
SCALE SIZE	C	
SHEET 1 OF 1		DWG NO. G-200082
		REV 2

UNLESS OTHERWISE SPECIFIED
DIMENSIONS ARE IN INCHES
TOLERANCES ARE:
FRACTIONS DECIMALS ANGLES
±1/4 XX ±.50 ±1/2°

LT29050.DWG