

REVISIONS				
ZONE	REV	DESCRIPTION	DATE	APPROVED
	2	REDRAWN TO AUTOCAD	09-24-09	

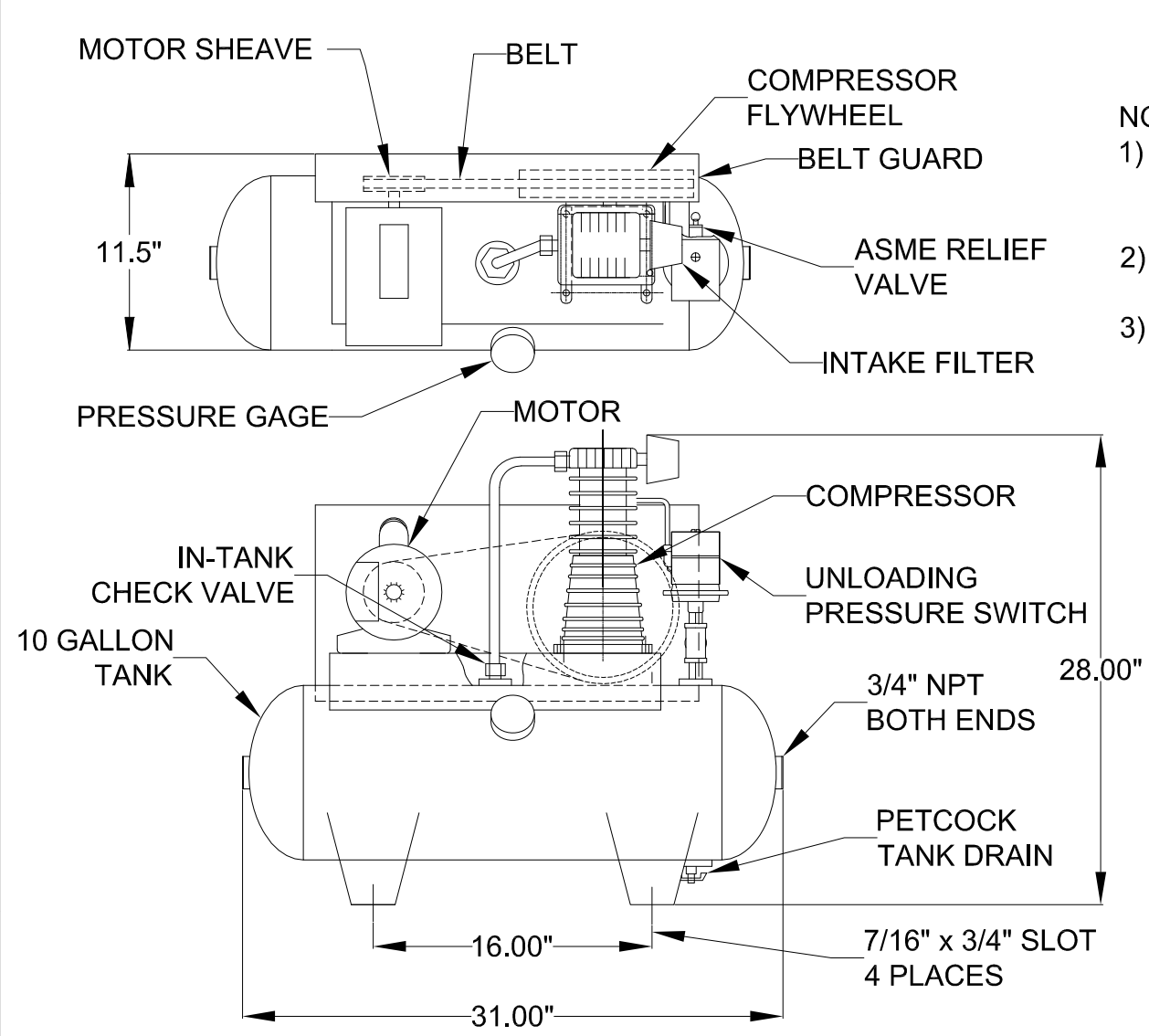

- NOTES:**
- 1) THIS DRAWING REPRESENTS MULTIPLE ASSEMBLIES. SEE TABLE BELOW FOR MODELS REPRESENTED.
 - 2) REFERENCE INDIVIDUAL PARTS LISTS FOR COMPONENT PART NUMBERS.
 - 3) REFERENCE INSTRUCTION MANUAL FOR INSTALLATION AND WIRING RECOMMENDATIONS.

MODEL	VOLTAGE
LT425100A	115/208-230V/60HZ/1PH
LT425100A-50	110/220V/50HZ/1PH
LT425100B	230/460/60HZ/3PH
LT425100B-50	190/380V/50HZ/3PH

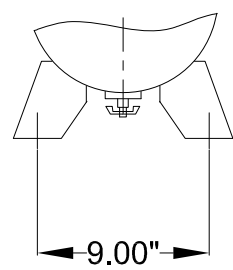

APPROVALS	DATE	TITLE
DRAWN EJR	09-24-09	GENERAL ARRANGEMENT 1 HORSEPOWER TANK MOUNTED LUBRICATED COMPRESSOR
CHECKED DPH	09-24-09	
SCALE	SIZE	DWG NO.
1 OF 1	C	G-200084
		REV 2

UNLESS OTHERWISE SPECIFIED
DIMENSIONS ARE IN INCHES
TOLERANCES ARE:
FRACTIONS DECIMALS ANGLES
±1/4 XX ±.50 ±1/2°