

REVISIONS				
ZONE	REV	DESCRIPTION	DATE	APPROVED
	2	REVISED AND REDRAWN TO AUTOCAD	09-24-09	

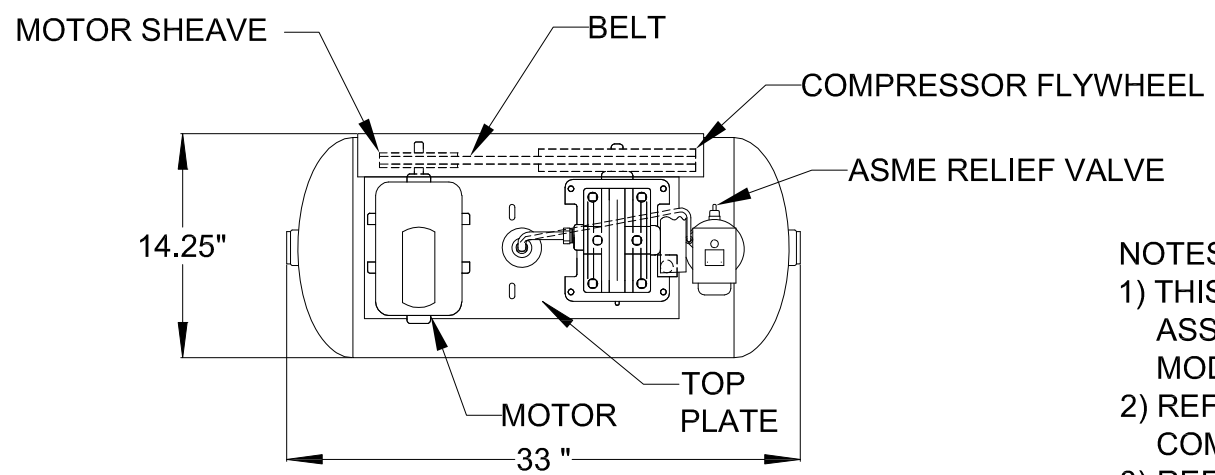

- NOTES:**
- 1) THIS DRAWING REPRESENTS MULTIPLE ASSEMBLIES. SEE TABLE BELOW FOR MODELS REPRESENTED.
 - 2) REFERENCE INDIVIDUAL PARTS LISTS FOR COMPONENT PART NUMBERS.
 - 3) REFERENCE INSTRUCTION MANUAL FOR INSTALLATION AND WIRING RECOMMENDATIONS.

MODEL	VOLTAGE
LT900150A	115/208-230V/60HZ/1PH
LT900150A-50	110/220V/50HZ/1PH
LT900150B	230/460/60HZ/3PH
LT900150B-50	190/380V/50HZ/3PH

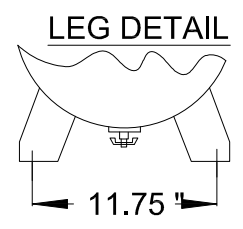
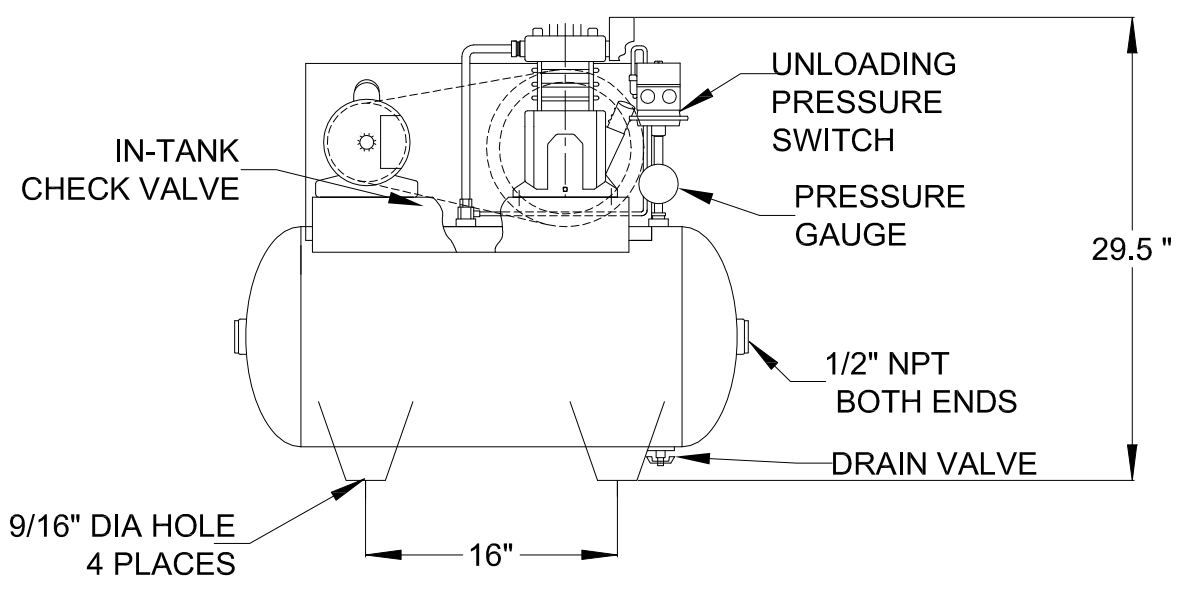

GENERAL
AIR PRODUCTS

APPROVALS	DATE	TITLE
DRAWN EJR	09-24-09	GENERAL ARRANGEMENT
CHECKED DPH	09-24-09	1 1/2 HORSEPOWER TANK MOUNTED
SCALE	SIZE	LUBRICATED COMPRESSORS
SHEET 1 OF 1	C	DWG NO. G-200086
		REV 2

UNLESS OTHERWISE SPECIFIED
DIMENSIONS ARE IN INCHES
TOLERANCES ARE:
FRACTIONS DECIMALS ANGLES
±1/4 XX ±.50 ±1/2°