

TANK MOUNTED LUBRICATED COMPRESSOR INSTRUCTION SHEETS

DANGER

This compressor is not equipped and should NOT be used "as is" to supply breathing quality air.

WARNING

Motors, electrical equipment and controls can cause electrical arcs that will ignite a flammable gas or vapor. Never operate or repair in or near a flammable gas or vapor. Never store flammable liquids or gases near the compressor.

WARNING:

These compressors are suitable for pumping only atmospheric air. As defined in Compressed Gas Association Pamphlet G-7, page 3, atmospheric air is a mixture of elements and compounds where nitrogen and oxygen comprise more than 99% with all other trace gases comprising less than 1%. **DO NOT USE THIS COMPRESSOR IN CONTAMINATED ENVIRONMENTS OR FOR PUMPING MIXTURES OTHER THAN ATMOSPHERIC AIR**

WARNING

Compressed air contains liquid water and is saturated with water vapor, which can freeze, when surrounding temperatures are lower than 32 F. Component selection to minimize the effects of water vapor must be considered.

Receiving

Your compressor is inspected at the factory and packaged to protect against shipping damage. When the compressor is unpacked, inspect for damage or missing parts. All claims should be settled directly with the freight company.

WARNING: Do not operate this compressor if damaged during shipment, handling, or use. Damage may result in bursting and cause injury or property damage.

Location

NOTE: Do not connect compressor intake to freezer room. – CALL 1-800-345-8207.

Locate the compressor in a clean, well-ventilated area where the air is relatively cool, clean, and dry. A 110°F (35 C) maximum and 40°F (4.5 C) minimum temperature for surrounding and inlet air are recommended. Provide at least 12 to 18 inches from any wall or other obstruction that will interfere with airflow through the fan bladed flywheel. The flywheel is located inside the belt guard. Blocking airflow through the flywheel may cause the compressor to over heat. Do not place the

compressor in an area of excessive heat, such as near a boiler.

Mounting

The compressor must be mounted to a firm level floor. Permanent installations should be bolted to the floor using the bolt holes provided in the tank legs. Always shim the unit level before bolting it to the floor. Vibration isolators (P/N KVP4X4) are recommended. When using isolator pads, do not draw bolts tight. Allow the pad to absorb vibrations. When isolators are used, a flexible hose (P/N P1202MP) should be installed between the compressor and service piping.

Lubrication

NOTE: This compressor is shipped without oil installed. Add oil provided, P/N APC01Q, before operation.

Specially formulated compressor oil (P/N APC01Q) is shipped with each unit. This oil should be used to initially fill the oil reservoir and for maintenance oil changes. Do not overfill the oil reservoir. Overfilling the reservoir will result in oil leaking from the reservoir breather during operation. Single cylinder compressors, L20033 and L29050 require 8 ounces of oil. L36575 and L425100, without a sight glass, require 8 ounces of oil. L36575 and L425100

❄️ **GENERAL AIR PRODUCTS, INC.**

models with sight glasses require 12 ounces of oil. Two cylinder compressors with a dipstick, LT620100 to LT1300300, should be filled until the oil reaches the notch on the end of the dipstick, approximately 22 ounces. The largest four cylinder compressors, LT1600300 and LT2000500 and the larger two cylinder compressor, LT2500500, have an oil level window. Oil should be filled to the midpoint of the window on these models, approximately 1 ½ quarts.

Piping (reference “Installation Instructions” drawing)

WARNING

Compressed air contains liquid water and is saturated with water vapor, which can freeze, when surrounding temperatures are lower than 32 F. Component selection to minimize the effects of water vapor must be considered.

Piping between the compressor, accessory items and the sprinkler system should be at least ½” internal diameter to minimize pressure drop from the compressor to system. Larger pipe size may be required by code and may be substituted with no adverse effects. Smaller line size must not be used and will restrict the compressor flow, lowering capacity and causing the compressor/motor to work harder, which shortens compressor/motor life. All piping connected to the compressor must be fully supported and not transfer any loads to the compressor.

A relief valve is mounted on the compressor’s tank. This valve will open at a preset value above the pressure switch setting to prevent excess tank pressure in the event of switch failure.

WARNING: Do not attempt to change the safety relief valve setting.

If an AMD-1 is used, allow sufficient distance between the compressor and AMD-1 to ensure that the maximum temperature at the AMD-1 is 200°F or less.

A manual drain is provided on the bottom of each tank mounted compressor. Moisture accumulated in the tank, must be drained weekly. An automatic drain, P/N DVA-2T, is recommended in areas of high humidity.

The compressor outlet piping should contain an accessible drain. As a minimum a manual drain may be used, but an automatic drain is recommended to remove excess water.

NOTE: Accumulation of condensed water in a system causes corrosion of components and reduces system capacity.

NOTICE: Warranty is void if a separate check valve is not installed to prevent water back flow.

Wiring (reference “Wiring Instructions” drawing)

WARNING

Have a competent electrician wire the compressor to ensure that the supply line has the same characteristics (voltage, frequency and phasing) as the motor. Wiring must comply with all local and national codes.

CAUTION

Inadequate wiring size can cause insufficient voltage at the compressor during start-up. Overheating and damage may result to the motor and controls.

The supply wire must be of adequate size and no other equipment should be connected to the same line. The table below lists the recommended wire size for each model, based on a 100’ run. Consult factory for longer runs.

MINIMUM RECOMMENDED WIRE		
MODEL	1 PHASE	3 PHASE
LT20033*	10	12
LT29050*	8	12
LT36575*	8	12
LT425100*	6	12
LT620100*	6	12
LT900150*	6	10
LT1220200*	4	10
LT1300300*	4	8
LT1600300*	2	8
LT2000500*	2	6
LT2500500*	2	6

The motor must be wired to the pressure switch provided, which controls starting (cut in pressure) and stopping (cut out pressure) of the motor. The pressure switch is factory set at 30 psig cut in and 40 psig cut out. Higher settings may require a larger motor on the compressor. Consult General Air Products before adjusting the pressure switch.

NOTE: Failure to use the pressure switch may result in overpressure of the compressor or other components in the system. Overpressure of the compressor may result in blown head gaskets or other damage.

❄️ *GENERAL AIR PRODUCTS, INC.*

A magnetic starter is recommended to protect the motor from overload conditions. Running two phases, of a three phase supply, through a pressure switch is not recommended.

The motors supplied are multiple voltage motors. It is necessary to verify the internal motor leads are connected for the voltage being supplied to the unit. To verify or change internal voltage connections, remove the cover plate located on the rear or side of

the motor and reconnect the wire leads as shown on the motor's wiring diagram.

An arrow on the belt guard indicates the direction of rotation of the compressor. If the compressor rotates in the opposite direction, reverse the rotation of the motor. Direction of rotation of single phase motors is controlled by internal reconnection of the motor leads as shown on the motor's nameplate. Interchanging any two incoming supply wires reverses rotation of three phase motors.

Maintenance Instructions

WARNING

DISCONNECT, TAG AND LOCK OUT POWER SOURCE THEN RELEASE ALL PRESSURE FROM THE SYSTEM BEFORE ATTEMPTING TO INSTALL, SERVICE, RELOCATE OR PERFORM ANY SERVICE.

The following instructions are based on NORMAL operation. If the compressor is in an excessively dusty area, increase frequency of maintenance checks.

WEEKLY

- Check oil level.
- Drain condensate from receiver and traps.
- Check for unusual noise or vibration.
- Clean air filters.
- Clean all external parts of the compressor and motor.

MONTHLY

- Manually test safety relief valve.
- Inspect air system for leaks.
- Inspect oil for contamination and change if necessary.
- Check for belt tension and wear.
- Check pulley set screws for tightness.
- Tighten nuts and cap screws as required.

QUARTERLY

- Change oil.
- Change filters.

Limited Warranty

General Air Products, Inc. warrants its products to be free of defects in material and workmanship under normal use and service for 12 months from date of purchase. Our warranty applies only when such defective parts are returned to us, or our Authorized Service Depot, transportation prepaid, and subject to our inspection and approval. Liability is limited to repair or replacement of material found defective, free of charge, FOB our plant. Unauthorized repairs or replacements will not be subject to factory warranty. This warranty is in lieu of all other warranties, expressed or implied.

General Notes

- 1) Warranty can be voided if modifications or adjustments are made without consultation and approval; from factory personnel.
- 2) If there are any questions regarding installation or operation of this compressor, please call the 800 number listed below

Trouble Shooting Guide

Symptom	Possible Cause(s)	Corrective Action
Motor hums and runs slowly or not at all	<ol style="list-style-type: none"> 1. Low voltage or no voltage 2. Shorted or open motor winding 3. Defective check valve or unloader valve 4. Defective pressure switch – contacts will not close 	<ol style="list-style-type: none"> 1. Check voltage during attempt to start. Voltage must be within +/-10% of nominal voltage to start motor. Increase wire size if necessary to lower voltage drop. 2. Replace motor 3. Replace check valve or unloader valve 4. Repair or replace pressure switch
Reset mechanism cuts out repeatedly or fuses blow repeatedly	<ol style="list-style-type: none"> 1. Insufficient voltage to motor 2. Pressure switch set too high 3. Wrong fuse size 4. Piping too restrictive 5. Defective motor 	<ol style="list-style-type: none"> 1. Check voltage during attempt to start. Voltage must be within +/-10% of nominal voltage to start motor. Increase wire size if necessary to lower voltage drop. 2. Consult factory, adjust or replace 3. Be sure fuses and heaters are rated properly 4. Add receiver vessel or increase pipe volume after compressor. 5. Replace motor
Unit short cycles repeatedly	<ol style="list-style-type: none"> 1. Piping too restrictive 2. Leak near pressure switch 	<ol style="list-style-type: none"> 1. Add receiver vessel or increase pipe volume after compressor. 2. Repair leaks(s)
Compressor Overheating	<ol style="list-style-type: none"> 1. Dirty intake filter 2. Wrong motor rotation 3. Air flow to fan on flywheel blocked 	<ol style="list-style-type: none"> 1. Clean intake filter 2. Correct rotation 3. Clear air flow to fan or relocate unit
Excessive noise in operation	<ol style="list-style-type: none"> 1. Loose pulley, flywheel, belt guard etc. 2. Lack of oil in crankcase 3. Compressor mounting loose 	<ol style="list-style-type: none"> 1. Tighten 2. Check for damage to bearings, replenish oil 3. Shim and tighten
Milky oil in reservoir	<ol style="list-style-type: none"> 1. Water flow from system into compressor 2. Water condensing in crankcase due to high humidity 	<ol style="list-style-type: none"> 1. Separate check valve to prevent water flow from system not installed or defective. Install or repair check valve. 2. Pipe air intake to less humid area. Run pump continuously for one hour.
System pressure builds slowly	<ol style="list-style-type: none"> 1. Compressor sized incorrectly 2. Leaks or restrictions in piping 3. Dirty intake filter 4. Blown head gasket 	<ol style="list-style-type: none"> 1. Check system size and compressor sizing 2. Correct leaks and remove restrictions 3. Clean intake filter 4. Replace head gasket

ALL PIPING AND WIRING TO BE IN ACCORDANCE WITH APPLICABLE STATE, LOCAL AND NATIONAL CODES & SHOULD BE APPROVED BY AHJ

TANK MOUNTED LUBRICATED COMPRESSORS INSTALLATION INSTRUCTIONS



MULTIPLE CHECK VALVES IN FEED LINES CAN RESULT IN LOWER SYSTEM PRESSURES DUE TO PRESSURE DROPS

IF SYSTEM IS FEEDING FREEZER ROOM, CONSULT FACTORY FOR DRY AIR PAC INFORMATION.

CONNECT TO REQUIRED SYSTEM TRIM

200 F MAX.



P/N AMD - 1
AIR MAINTENANCE DEVICE

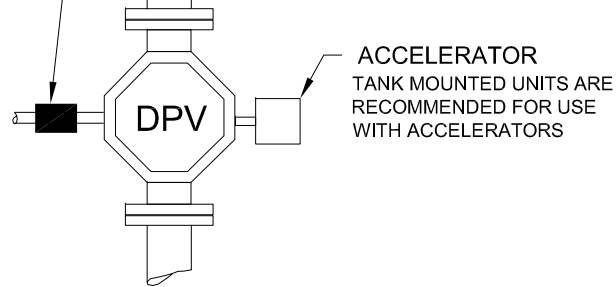

ACCELERATOR
TANK MOUNTED UNITS ARE RECOMMENDED FOR USE WITH ACCELERATORS

MOST MOTORS ARE MULTIPLE VOLTAGE. CHECK NAMEPLATE AND VERIFY INTERNAL CONNECTIONS FOR VOLTAGE BEING SUPPLIED TO UNIT.

INSTALL ALLOWING EASY ACCESS TO BELTGUARD FOR MAINTENANCE CHECKS

MAGNETIC STARTER RECOMMENDED (CONSULT APPLICABLE CODES)

NOTE: UNITS ARE SHIPPED WITHOUT OIL INSTALLED. ADD OIL (P/N APC01Q) BEFORE OPERATING

1/2" MINIMUM, LARGER IF REQUIRED BY CODE

FLEX HOSE P/N P1202MP

PRESSURE SWITCH MUST BE WIRED IN CIRCUIT TO CONTROL COMPRESSOR.

PRESSURE SWITCH IS FACTORY SET AT 30# CUT IN 40# CUT OUT; HIGHER PRESSURE SETTINGS MAY REQUIRE A LARGER MOTOR ON THE COMPRESSOR, CONSULT FACTORY FOR DETAILS.

MANUAL DRAIN RECOMMENDED AS MINIMUM.

OR

AUTOMATIC DRAIN (P/N FD-1) RECOMMENDED ON DRIP LEG TO REMOVE EXCESS WATER.

MANUAL DRAIN STANDARD; AUTOMATIC DRAIN (P/N DVA-2T) RECOMMENDED FOR HUMID AREAS.

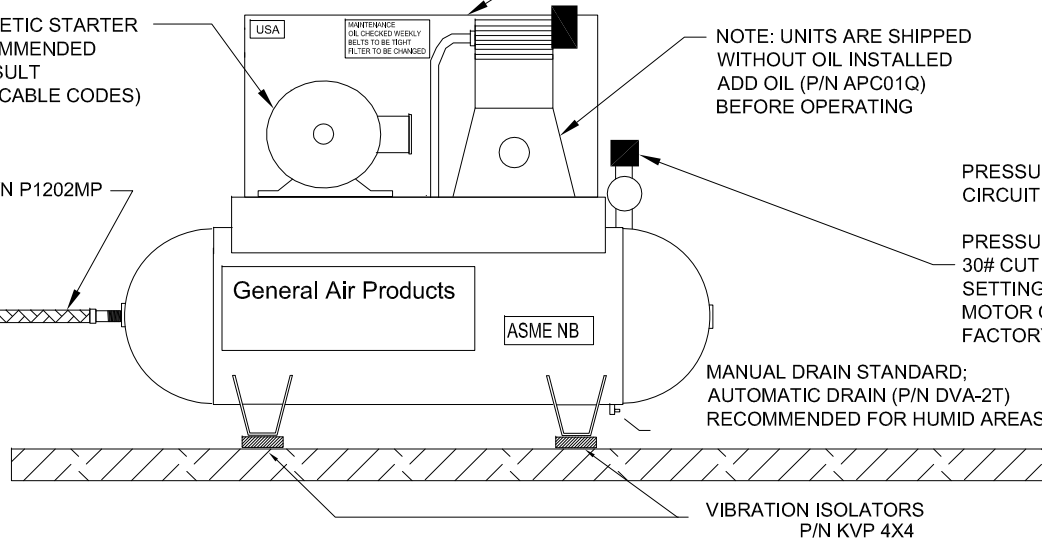

VIBRATION ISOLATORS
P/N KVP 4X4

PART NUMBERS LISTED ARE FOR ACCESSORY ITEMS RECOMMENDED FOR COMPLETE INSTALLATION - CONSULT YOUR LOCAL DISTRIBUTOR FOR AVAILABILITY

WARNING!
DO NOT INSTALL IN AREAS EXPOSED TO TEMPERATURES BELOW 40 DEGREES F. OR AREAS EXPOSED TO WEATHER. CONSULT FACTORY FOR WEATHERPROOF OPTIONS.

REVISIONS				
ZONE	REV	DESCRIPTION	DATE	APPROVED
	1	REDRAWN TO AUTOCAD	10-03-05	
	2	ADDED TERMINALS 1L1 & 3	11-02-05	

NOTE: MOST MOTORS ARE MULTIPLE VOLTAGE. CHECK NAMEPLATE AND VERIFY CORRECT INTERNAL CONNECTIONS FOR VOLTAGE BEING SUPPLIED TO UNIT.

FEEDER WIRE SIZE MUST BE CAPABLE OF CARRYING CURRENT LOAD OF COMPRESSOR AT MAXIMUM PRESSURE.

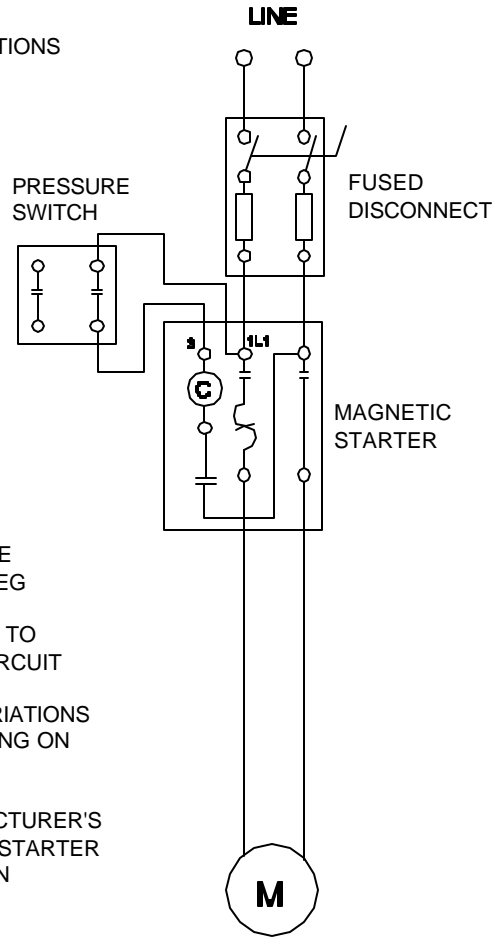

FIG 1
SINGLE PHASE

FOR 115V ELIMINATE FUSE IN GROUND LEG

PRESSURE SWITCH TO CONTROL PILOT CIRCUIT

OTHER WIRING VARIATIONS POSSIBLE DEPENDING ON LOCAL CODES

CONSULT MANUFACTURER'S INSTRUCTIONS ON STARTER FOR VARIATIONS ON DIAGRAM

FIG 1

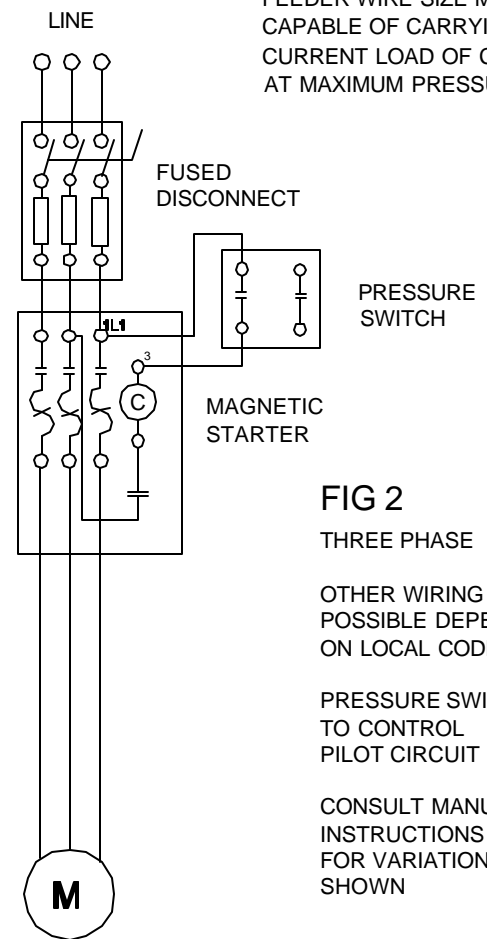

FIG 2
THREE PHASE

OTHER WIRING VARIATIONS POSSIBLE DEPENDING ON LOCAL CODES

PRESSURE SWITCH TO CONTROL PILOT CIRCUIT

CONSULT MANUFACTURER'S INSTRUCTIONS ON STARTER FOR VARIATIONS ON DIAGRAM SHOWN

FIG 2

UNLESS OTHERWISE SPECIFIED
DIMENSIONS ARE IN INCHES
TOLERANCES ARE
FRACTIONS DECIMALS ANGLES
±1/4 .004-13 ±1/2°

GENERAL
AIR PRODUCTS

APPROVALS	DATE	WIRING INSTRUCTIONS SINGLE AND THREE PHASE LUBRICATED COMPRESSOR
DRAWN		
EJR		
DESIGNED		
CHKD		
SCALE		DWG NO. E-205126
INTS		REV 2
SHEET	1 OF 1	