



Dry Air Pac™

ENGINEERED COMPRESSED AIR DRYING SYSTEMS
 FOR DRY PIPE SPRINKLER SYSTEM CORROSION MITIGATION
 AND COLD STORAGE / FREEZER ROOM APPLICATIONS

Installation, Operation and Maintenance Manual

MODELS DAP500, DAP1000 & DAP2000

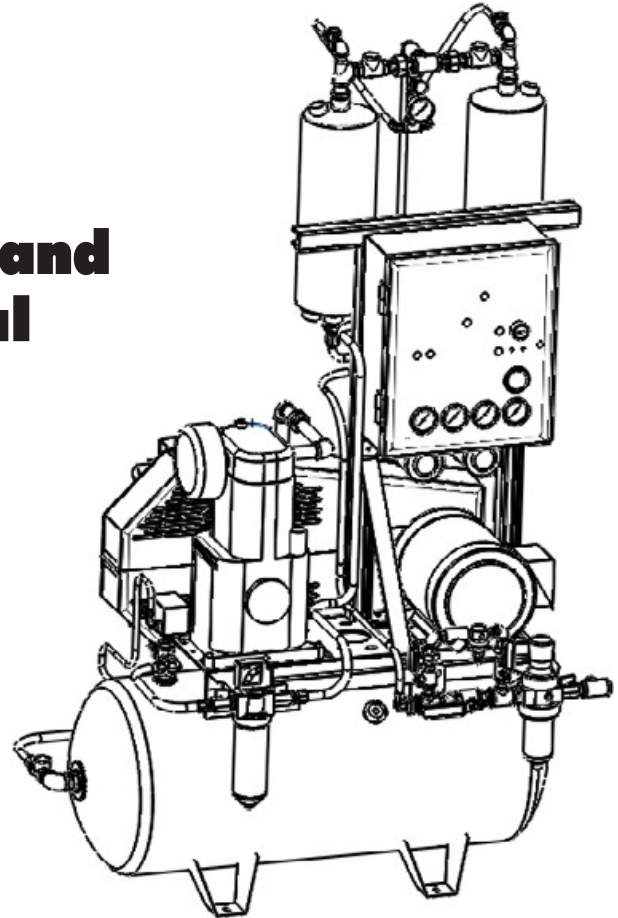

Model Number	System Capacity*	Compressor HP	Dryer Rating SCFM	Approximate Shipping Weight
DAP500	500 Gallon	2	10	375lbs
DAP1000	1000 Gallon	5	20	500lbs
DAP2000	2000 Gallon	5	27	550lbs

* System capacity is +/- 10% due to site location and conditions.

Call **1-800-345-8207**
 or visit our web site for our complete product listing
www.GeneralAirProducts.com

Table of Contents

Safety Guidelines

Section 1 - Installation Instructions

- 1.1 Location
- 1.2 Changing the Oil
- 1.3 Electrical Connection
- 1.4 Prior Run Time
- 1.5 Filter
- 1.6 Dew Point Monitor
- 1.7 DAP Outlet
- 1.8 DAP Air Maintenance Device
- 1.9 Electronic Drain Valve

Section 2 - Start-Up Instructions

Section 3 - Operation

- 3.1 - Description of Operation
- 3.2 - Setting Purge Pressure
- 3.3 - Coalescing Filter Operation
- 3.4 - Dryer Operating Sequence

Section 4 - Additional Specifications

Section 5 - Desiccant Replacement

Section 6 - Setting Pump Head Bolt Torque

Section 7 - Trouble Shooting Guide

Section 8 - Dry Air Pac General Arrangement

- 8.1 - General Arrangement for Models DAP 1000 & DAP 2000
- 8.2 - General Arrangement for Models DAP 500

Section 9 - Dry Air Pac Electrical Schematics

Section 10 - P&ID Diagram

Section 11 - Warranty Policy

**IMPORTANT: ALL INFORMATION SUBJECT TO CHANGE WITHOUT NOTICE.
Consult factory for the most up to date version of this manual - 1-800-345-8207.**

Safety Guidelines

This manual contains information that is very important to know and understand. This information is provided for SAFETY and to PREVENT EQUIPMENT PROBLEMS. To help recognize this information, observe the following symbols.



Danger indicates an imminently hazardous situation which, if not avoided, WILL result in death or serious injury.



Warning indicates a potentially hazardous situation which, if not avoided COULD result in death or serious injury.



Caution indicates a potentially hazardous situation which, if not avoided, MAY result in minor or moderate injury.



Notice indicates important information, that if not followed may cause damage to equipment.

Section 1 - Installation Instructions

1.1 Location

Install DRY AIR PAC in a clean, dry location, with ambient temperatures above 50° F at all times, adjacent to the sprinkler system piping outside the cold room.



When a Dry Air Pac is supervising more than one system, ensure each system falls under the model's rated air fill capacity. Consult factory for further sizing recommendations

The unit must be accessible on all sides for air flow and servicing all major components. The unit must be leveled and anchored to the floor (the vibration isolators supplied with the unit MUST be utilized). If the location is below freezing at any time the unit must be enclosed in a separate, heated enclosure to keep the temperature above 50° F.



Do not install the Dry Air Pac in an area where ammonia vapors or similar contaminants exist. The equipment and desiccant can be damaged by ammonia and other vapors. Locate the Dry Air Pac to ensure no ammonia or other vapors are drawn into the intake.

1.2 Changing the Oil

The Dry Air Pac has been filled with oil for test purposes. Check oil level when installing the unit. It is recommended to change oil annually or every 500 hours of run time, whichever comes first. 2 Quarts of oil are shipped with each Dry Air Pac. When adding or replacing oil only use General Part Number ACPO1Q Specially Formulated Compressor Oil.

Oil requirements are as follows:

DAP500	Approximately 8.5ounces (middle of oil level window)
DAP1000	Approximately 1 1/2 quarts (middle of oil level window)
DAP2000	Approximately 1 1/2 quarts (middle of oil level window)



Oil must be the non-detergent type. Lightweight lubricants and heavy gear oils should not be used.

Section 1 - Installation Instructions (cont'd)

1.3 Connecting Voltage

Connect supply voltage to separate line terminals L1, L2 and L3 on terminal block. All wiring must conform to the National Electrical Code (NEC) and any local or building codes.



Wire size must be capable of carrying the unit load without dropping the voltage at the terminals below normal operating levels. Check incoming wire size; if there are any questions please contact us. Check all wire connections in control cabinet, since they may loosen during shipment.

Be sure the control power transformer has its primary side jumpers connected to match the incoming supply voltage. Each unit is run at the factory. Motor rotation will always need to be checked. After connecting the power, use the on/off switch on the front of the unit to turn on the compressor briefly to check rotation. An indicating arrow is on the compressor flywheel. If rotation is not correct on three phase units, reverse any two leads.

On single phase units refer to the motor nameplate, however it should not require changing as it has been run at the factory. If you feel this is required please consult with factory personnel as there may have been changes made to the unit, which should be discussed with the factory PRIOR TO starting the unit. Please ensure sufficient power is available at the unit. Long feed line runs can cause voltage drops, which can affect the performance of the unit and damage the motor.



Only qualified electrical personnel should connect the unit.

1.4 Prior Run Time

Each Dry Air Pac is shipped with desiccant installed. Run the unit for a 1/2 hour before connecting to the sprinkler system. This will allow the desiccant to become conditioned to the proper dew point. Throttle outlet valve to maintain air drying tower pressure between 70 psig and 100 psig during this period.



The Dry Air Pac should not run for more than 40 minutes in any given hour.



If you are connecting to an old piping system there may be existing leaks in the system which cause the compressor to cycle more frequently than 4 times per hour. If this is the case there are three suggestions: 1. Fix the leaks. 2. Add a second Dry Air Pac to provide enough air to bring the cycle times back to less than 4 times per hour. 3. Add a receiver, which can act as a storage buffer to supply more air to the system. This should be discussed with factory personnel, as it will only work in cases where minor leaks are involved.

1.5 Filter

The Dry Air Pac is supplied with a removable, threaded inlet air filter so that if the AHJ requires air to be drawn from the cold room this can be done.



These units have been FM Approved with air not being drawn from the freezer room. Therefore we do not recommend they be connected to the freezer room.

The Dry Air Pac is designed so that performance will not be adversely affected with the filter left in place directly on the compressor. If connected in the cold room, the piping back to the compressor must be 1 1/2" minimum pipe size for this run, bushed down directly at the compressor inlet. This pipe must be heat traced and insulated. The inlet filter should be mounted on the inlet end of this pipe directly in the cold room. The interconnecting piping must be clean of any foreign matter, which may be drawn into the compressor and cause damage.

1.6 Dew Point Monitor

There is a 1/2" pipe plug installed in the outlet tee. This is provided as a point to install a dew point monitoring device, should you require one. This is after the regulator and gives you the pressure dew point of the system. Be careful to follow the dew point monitor manufacturer's recommendations regarding installation.

Section 1 - Installation Instructions (cont'd)

1.7 DAP Outlet

The Dry Air Pac outlet is from the combination particulate filter with pressure regulator, mounted on the lower right side of the unit facing the control panel. Connect this outlet to the sprinkler system air inlet.

1.8 DAP Air Maintenance Device

The Dry Air Pac has a UL Listed/FM approved Air Maintenance Device built into the unit. It must be adjusted to system requirements. It replaces the final regulator, which should be left fully open once the Air Maintenance Device has been adjusted and valved into the line. If connecting more than one system to the unit, the Air Maintenance Device should be in the fill position and the individual AMD's used to control each system should be utilized.



Leaks in the piping system will affect the pump up time of the system. The Dry Air Pac has been factory tested to produce the published capacity, for systems without leaks.

1.9 Electronic Drain Valve

An electronic drain valve is installed on each unit. The drain is pre-set when the unit leaves the factory. If necessary you can adjust the time between openings and the length of time the valve is open using the control knobs located on the front of the control panel. Under normal circumstances the maximum time between openings should be sufficient. If more frequent openings are required due to excessive compressor operation simply decrease the duration between openings. The Automatic-Off-Manual Test switch can be used to check operation. Leave this switch in "Automatic" during normal operation.

Section 2 - Start-Up Instructions

As noted previously, the unit must run for a minimum of a 1/2 hour before air is taken from the Dry Air Pac into the sprinkler system. Follow instructions in section 1.4

With all the connections made as described in "Installation Instructions", the unit is ready to start. With the valve ahead of the coalescing filter closed, turn the unit on. The compressor will start to fill the receiver tank and the tank pressure gauge on the front of the control panel will indicate the pressure. The unit will pressurize the receiver to approximately 100 psig and then shut off the compressor.



Do not adjust the pressure switch on the unit. It is factory set for correct operation of the unit. Warranty may be void if the pressure switch is reset.

When the compressor stops, the unloader line will operate to bleed off the pressure in the line from the compressor to the receiver inlet, so that the compressor does not start loaded. Air exhausts from the small valve at the side of the switch immediately after the compressor is shut off. This should not occur when the compressor is running or for long periods of time after the compressor shuts off. If this occurs, contact the factory.

Slowly open the valve ahead of the coalescing filter and pressurize the rest of the Dry Air Pac. The Air Maintenance Device should be in fill mode, with the 3/4" valve open.

Slowly open the outlet valve to pressurize the sprinkler system. The final regulator is factory set to 40 psig. The outlet valve should always be set to maintain pressure on the drying tower between 70 to 100 psig.



At no time should the outlet valve be opened to bleed all pressure off the drying system, as this adversely affects drying quality.

Section 2 - Start-up Instructions (cont'd)

If water in the pipe is a concern, the piping system can be dried as follows: Crack open an inspection test point on the far end of the sprinkler system to allow the current wet air in the sprinkler system to be purged out of the system. This leak should be adjusted to cause the compressor to run, after filling the system to pressure, no more than 4 times per hour. Allow this to run for 24 hours then close the inspection test port to allow the system to function normally. This procedure is an optional, extra step to ensure the piping system is as dry as possible and assumes proper pitch of piping and removal of standing water with low point drains as per NFPA 13.

The automatic drain is set to a mid position at the factory. You should not need to adjust frequency or duration but if you do, be aware that the quicker the cycle and the longer the open time, the more air will be used and the less will be available at the unit outlet. A light on the control panel will indicate when the drain is operating. The drain timing should be adjusted so all water in the air receiver is removed without bleeding excess air. A length of tubing is provided at the drain valve outlet for piping to a convenient drain or collection point.



Always keep the drain valve switch in the "Auto" position during operation.



Be sure to pipe this discharge to a location where the discharged air and water will not be a hazard to personnel. Follow local requirements for disposal of water and oil condensate.

Single Riser Installation: Once the system is filled, close the 3/4" valve on the air maintenance device, open the two 1/4" valves and set the regulator for final system maintenance pressure. The final regulator should then be fully opened to allow the air maintenance device to control system pressure.

Multiple Riser Installation: Set final regulator pressure at least 10 psi above highest pressure. Put air maintenance device into fill position (3/4" fill valve open). Adjust industrial system air maintenance devices as required.



If following the optional 24 hour drying procedure, remember to close the inspection port.

Section 3 - Operation

3.1 Description of Operation

The following is a description of the operation of the DRY AIR PAC.

Typically air is drawn into the compressor intake through the threaded inlet filter.



These units have been FM Approved with air not being drawn from the freezer room. Therefore we do not recommend they be connected to the freezer room.

If required by the AHJ, air is drawn in from the cold room through the inlet filter installed inside the cold room. This air then travels to the compressor intake via 1 1/2" minimum line size piping.

Air is drawn into the compressor intake and compressed through the compression cycle. The air then flows into the air cooled aftercooler where ambient air pulled over the coil cools the hot compressed air.

Water in the compressed air condenses out of the air as it cools and flows into the receiver. A check valve in this line prevents back flow to the compressor. The water settles to the bottom of the receiver and is discharged from the receiver when the automatic drain valve opens.

Air then leaves the receiver and goes into the coalescing filter where entrained oil is removed. The air then travels to the dryer inlet. The air is diverted to one drying tank by way of two solenoid valves. The air travels upwards through the desiccant bed and exits through the top of the tank. A portion of the dried air is diverted to the opposite tank by way of the purge valve and gauge/orifice combination. The purge pressure gauge setting is factory set (see following settings for each model). If re-setting is required, consult the factory for assistance.

Section 3 - Operation (cont'd)

The purge air enters the top of the offstream tower and travels downward to pick up the water molecules from the desiccant as the pressure drops to atmosphere. The wet purge air exits the bottom of the tank and is vented to atmosphere by way of the purge mufflers. The mufflers quiet the discharging air and also reduce the noise when the towers depressurize. The mufflers are removable for cleaning with soap and water periodically. Cleaning will ensure no build up, which will create back pressures in the tanks and decrease dryer performance. Both inlet and outlet of the tanks have screens to retain the desiccant.



Clean mufflers if pressure on the regenerating tower is above 0 psig.

The exiting air then goes to the Air Maintenance Device. (See Start Up above for operating positions). From the Air Maintenance Device the air goes into the final filter regulator. The air up to this point has been at 70 - 100 psig. When it leaves the filter regulator it is reduced to system pressure.



The dryer must operate at 70 to 100psig to function correctly. The air maintenance device regulator must be set and valved into the system.

3.2 Setting the Purge Pressure

The purge pressure set valve is located between the two tanks just over the top of the control panel. This valve is pre-set at the factory. If it needs to be adjusted for any reason, the following list shows the correct set pressures.



Consult factory before setting purge pressure.

UNIT	PURGE GAUGE	TOWER GAUGE
DAP500	20 psig	80 psig
DAP1000	35 psig	80 psig
DAP2000	25 psig	80 psig

3.3 Coalescing Filter Operation

The coalescing filter protects the desiccant dryer from oil carryover from the compressor. The filter has a built in differential pressure indicator with three color bands. Green is normal condition, yellow is warning that the element is going to need to be replaced, and red indicates the filter is overdue for replacement.

The filter has a built in automatic drain, which in normal service will expel accumulated oil or moisture from the bottom of the bowl. The drain can be tested by pushing up on the needle valve stem, which is in the mouth of the black outlet nipple on the bottom of the filter.

Service kits are available as detailed below. Model and serial numbers are required when ordering service kits.

KIT# KSMB01	Compressor Intake Filter Element(s), Coalescing Filter Element, Particulate After Filter Element and Compressor Oil
KIT# KAMA01	Same as Kit # KSMB01 and full desiccant charge for both dryer towers

Section 3 - Operation (cont'd)

3.4 Dryer Operating Sequence

The dryer operates on a 4-minute total cycle. There are four valves on the inlet manifold, and four on the outlet manifold. The outlet valves are check valves, which sequence automatically with the operation of the inlet valves. SV1 and SV2 are the inlet valves to the towers, SV3 and SV4 are the opposite purge valves such that when the left tower is drying and its inlet valve is open, the purge valve on that tower is closed.

With the unit turned on and the tank pressurized, air is ready to be used from the unit. As air is withdrawn from the unit into the sprinkler system, the receiver pressure will drop and the pressure switch will start the compressor. As the compressor runs, the dryer timer is energized. The drying tower is indicated by a light on the front of the panel and on the screen of the controller. The drying tower will show receiver pressure and the opposite tank, when purging, will show no pressure. When repressurizing prior to switch over, it will rise to receiver pressure. The purge valve can only be adjusted during the time the off line tower is purging and is showing no pressure. At this time, if necessary, adjust the purge pressure to the value in the above table when the on-stream tower pressure is 80 psig and purge tower pressure is 0 psig. The dryer cycle timer runs only when the compressor is running and accumulates time so that the length of the cycle on each tower does not get out of line with normal operation and does not saturate one desiccant bed. Purge valves are only open when the compressor runs. This minimizes compressor run time.

The frequency of change for the oil, filter elements and desiccant is highly dependent upon the following:

- Number of times the unit has to operate to satisfy the system air requirement. The tighter the system, the less the unit will have to run.
- Cleanliness of the environment in which the compressor is located.
- Maintenance schedule for the equipment.



As the desiccant will degrade (age) slightly over time, it is recommended that the desiccant be inspected once every year. This can be done by briefly removing the lower tower plugs to let a few beads out of each tower. Desiccant beads should be firm and white with very little dust. Replace desiccant if any yellowing or powdery conditions exist.



Turn off and depressurize the Dry Air Pac before removing tower plugs.



When the desiccant is replaced, all filter elements and oil should also be changed at that time if they have not been already. At a minimum the oil and filters should be changed every 750 run hours.

Section 4 - Additional Specifications

Model	Compressor HP	Dryer Rating CFM	Current Load 460V	Current Load 230V	Wire Size 460V	Wire Size 230V
DAP500	2	10	2.9 Amps	5.8 Amps	12 GA	12 GA
DAP1000	5	20	6.3 Amps	12.6 Amps	12 GA	10 GA*
DAP2000	5	27	6.3 Amps	12.6 Amps	12 GA	10 GA*

*IF UNDER 50' RUN 12 GA CAN BE USED HOWEVER, CHECK VOLTAGE WHILE RUNNING TO ENSURE NO UNDERVOLTAGE CONDITION EXISTS. FOR RUNS OVER 100' INCREASE WIRE SIZE TO CORRECT FOR VOLT DROPS.

Section 5 - Desiccant Replacement

NOTE: You will need the following in order to service the unit:
Annual Service Kit - "General" part number: KAMA01

1. Close the outlet valve of the unit and turn the power to the unit off.
2. Depressurize the unit completely by opening the petcock on the bottom of the receiver and checking the pressure gauges to ensure all air is removed. If air remains in the desiccant tanks, pull on the relief valve rings to depressurize the tanks.



All pressure must be out of the unit prior to working on the unit.



(A) Fill Port (B) Drain Port
(apply procedure to both tanks)

3. The tanks have separate desiccant fill and drain ports at the top and bottom.

4. Once the pressure has been removed from each tank, remove the lower (drain) port plug. Desiccant will drop out of the drain port. It is easiest to vacuum the desiccant out with a shop vac; however, the desiccant will drop out of the tower. You may have to probe the outlet with a thin probe in order to keep the desiccant from jamming together at the port. The desiccant is white in color; yellow means the desiccant has oil on it.

5. Ensure that all desiccant is removed from the tower. Replace the plug ensuring the threads are cleaned and re-doped with thread sealant before replacing.

CHECK the condition of the lower desiccant. As flow is upward through the bed, the lower desiccant will see any major contaminants and any carryover from the inlet filter if this has not been serviced correctly. Oil on the lower desiccant means that the filter element has been over saturated allowing oil to be carried over into the desiccant bed.

CHECK the filter drain and element before putting the new desiccant into the towers.



Consult the factory if any oil is in the towers.

7. Using "General" part number 34006-50, refill the tower with new, white desiccant. Refer to table at right for total amount of desiccant required for both towers.

Model	Desiccant Required
DAP500	25.5 lbs.
DAP1000	25.5 lbs.
DAP2000	37.8 lbs.



Only add desiccant beads to towers when refilling. Avoid adding chips and dust, which may be in the bottom of the bag of desiccant. Chips and dust can clog inlet and outlet tower screens, lowering dryer performance.

8. Reinstall the fill port ensuring that you clean the threads and re-dope prior to installation.

Section 5 - Desiccant Replacement (cont'd)

9. Remove and replace the pre & afterfilter elements prior to putting the unit back in service. This is accomplished by unscrewing the bowls and following the kit instructions to replace the elements. We would be happy to look at the old elements if you feel there is any question as to the condition. Please contact the factory for shipping instructions. Replace the filter bowls and tighten securely prior to re-pressurizing the unit.

10. Turn the power back on to the unit.

11. Close the discharge valve of the unit, and open the valve ahead of the coalescer. Turn power back on to the unit and allow the unit to repressurize. Check all joints for leaks and tighten if needed.

12. Operate the drain valve manually to bleed air to force the dryer through a full cycle to ensure that the towers pressurize and repressurize correctly and go through their cycle. This is simply a check to see that the unit is operating normally. The unit is now ready to go back in operation.

Run the unit for a 1/2 hour as above in INSTALLATION, before letting air feed back into the system.



The purge mufflers must be removed during this 1/2 hour period. Reinstall the mufflers only after the unit has run for a 1/2 hour.

Once this has been done, valve the unit back into the system.

Should you have any questions, please call the factory and ask for Customer Service at 1-800-345-8207.

Section 6 - Setting Pump Head Bolt Torque

1. Pump head bolts must be torqued to 35 ft/lbs after 40 hours of run time. Follow the torque sequence pictured below.

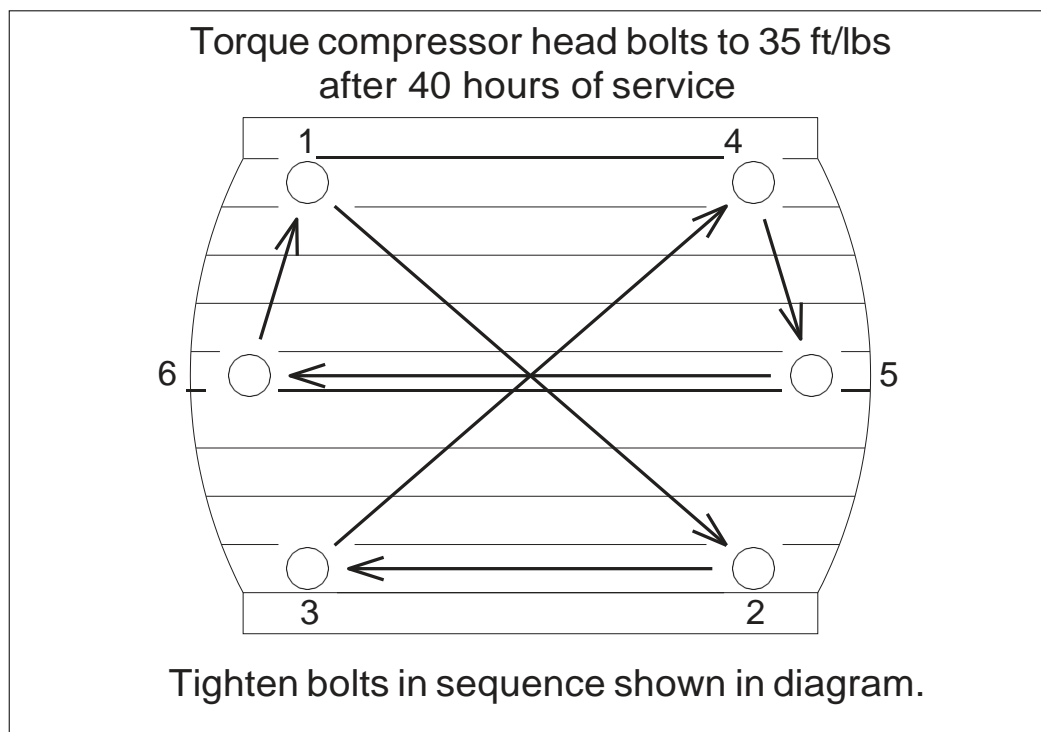

Section 7 - Trouble Shooting Guide

PROBLEM	PROBABLE CAUSE	SOLUTION
Poor Dewpoint Performance	Low pressure on desiccant dryer.	Dryer is set to operate at 70 to 100psig. Re-set regulator on DAP Air Maintenance Device, or throttle outlet to hold back pressure on dryer side to normal settings.
		Check to see that Air Maintenance Device bypass valve has not been opened.
		Check compressor output to ensure compressor is running normally.
		Check no leaks have developed in DAP system such as drain valve sticking open, filter drain valves sticking open, etc. Fix as needed
	Water and/or oil in dryer.	Check coalescing filter & automatic drain operation.
	Low purge flow.	Check purge pressure setting.
	Desiccant contamination.	Check compressor intake is not in an area where chemicals can be drawn into the intake filter with air.
		Check when the last time the desiccant was changed. Recommended frequency of change, every 3yrs.
		Check condition of desiccant. It should be pure white. Change desiccant if contaminated
		Check condition of coalescing filter element and drain.
High inlet temperature to dryer due to high flow rate.	Lower flow rate from unit. Fix system leakage.	
High inlet temperature to dryer due to high ambient temperature.	Lower ambient temperature or move unit to area less than 100°F	
Switchover Failure	Electric power loss	Turn dryer off; check connections to PLC and inlet to unit.
	Solenoid valve failure	Check valve operating sequence. Replace valve.

Section 7 - Trouble Shooting Guide

Problem	Possible Causes	Solution
Excessive Pressure Drop	Low inlet pressure.	Lower flow rate to system.
	Switching valve failure.	Check tower-operating sequence to verify and identify which valves are operating.
	Desiccant breakdown	Change desiccant
	Clogged filters	Change filter elements
	Valve shut	Open valve
Repressurization Failure or Purge Failure/ Tower Back-pressure	Purge flow control valve orifice clogged.	Clean or replace.
	Failed check valve.	Replace.
	Purge exhaust solenoid valve failure.	Turn dryer off, check connections to PLC, inspect valve and solenoid, replace if necessary.
	Purge exhaust muffler clogged.	Clean or replace.
Controller screen on unit not running	Insufficient / low voltage	Check voltage to and from transformer. Supply correct voltage to unit.

Section 8 - Dry Air Pac General Arrangement

8.1 General Arrangement for Models DAP 1000 & DAP 2000

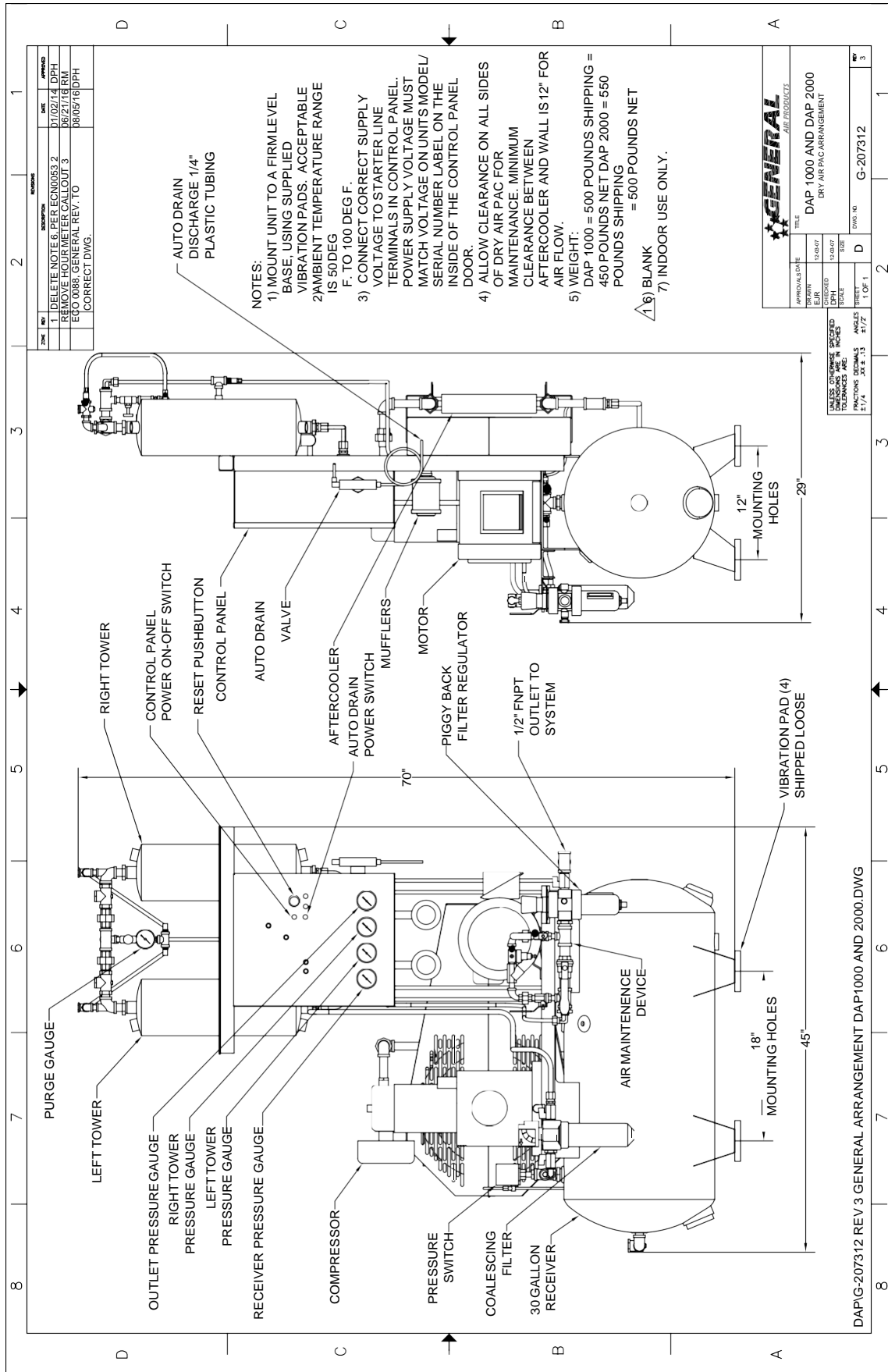

Section 8 - Dry Air Pac General Arrangement (cont.)

8.2 General Arrangement for Models DAP 500

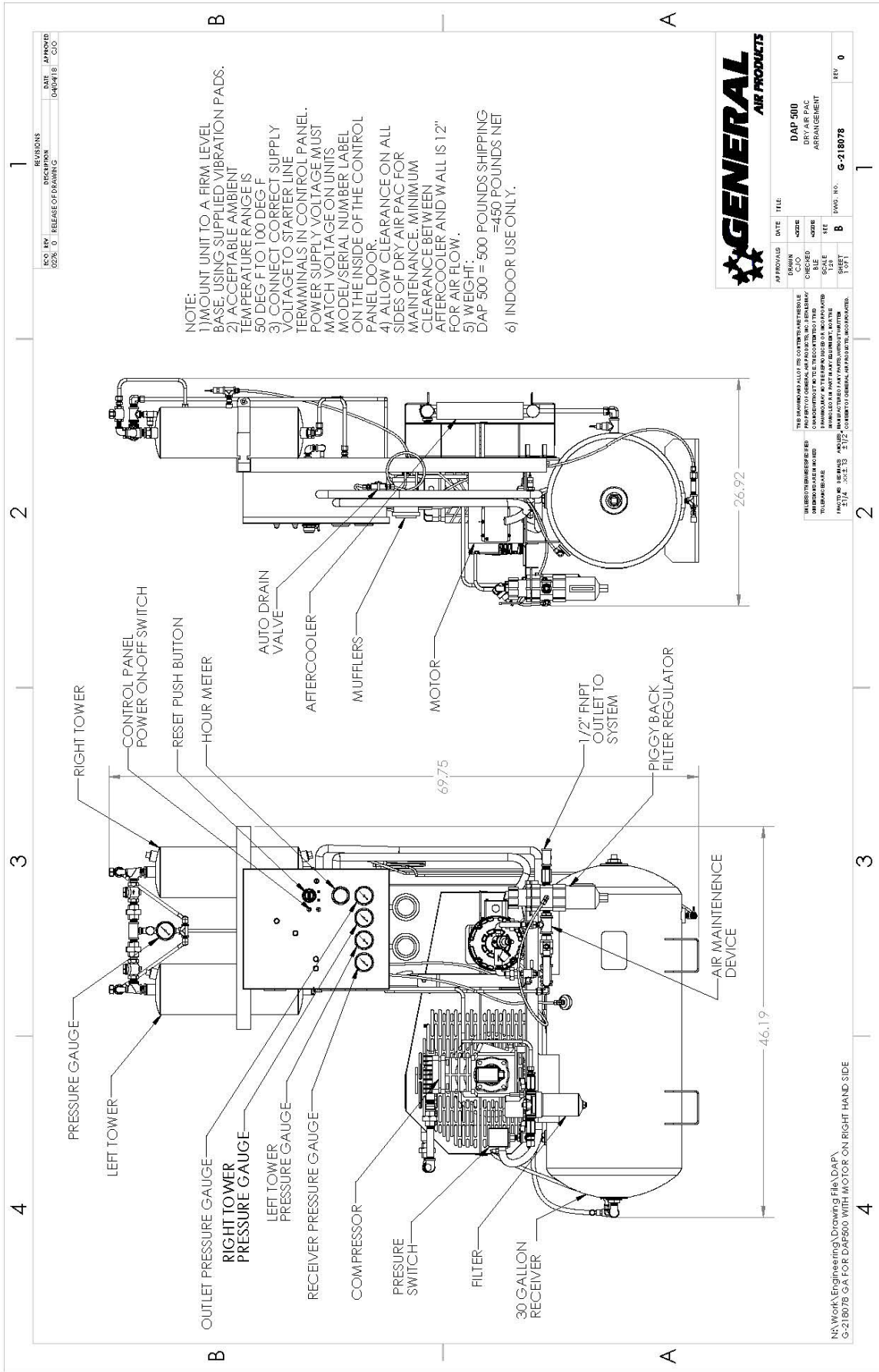

Section 9 - Dry Air Pac Electrical Schematics

9.1 Electrical Schematic - Wiring Diagram, DAP With PLC Option

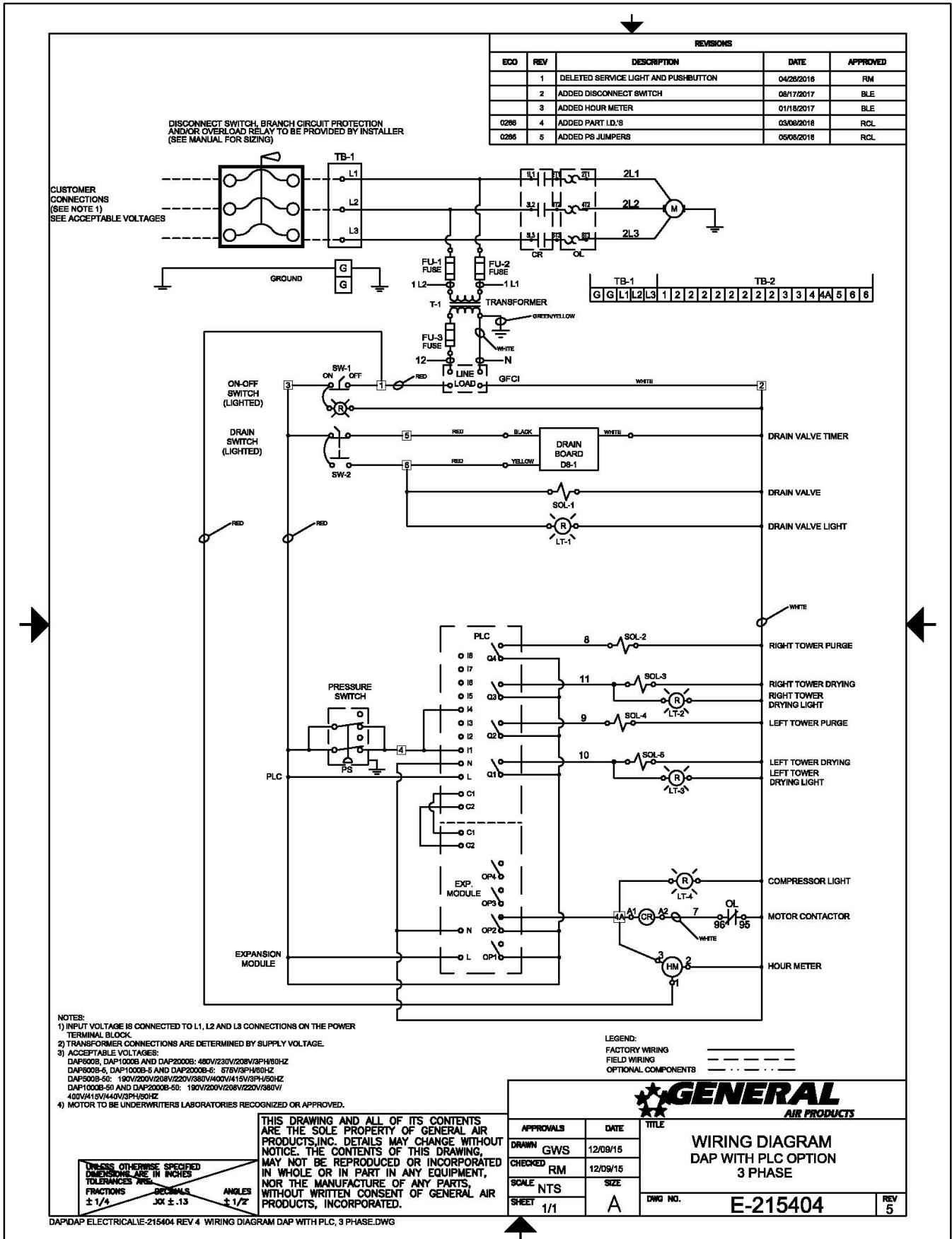

Section 9 - Dry Air Pac Electrical Schematics

9.2 Electrical Schematic - Single Phase, 115v/60hz or 110v/50hz

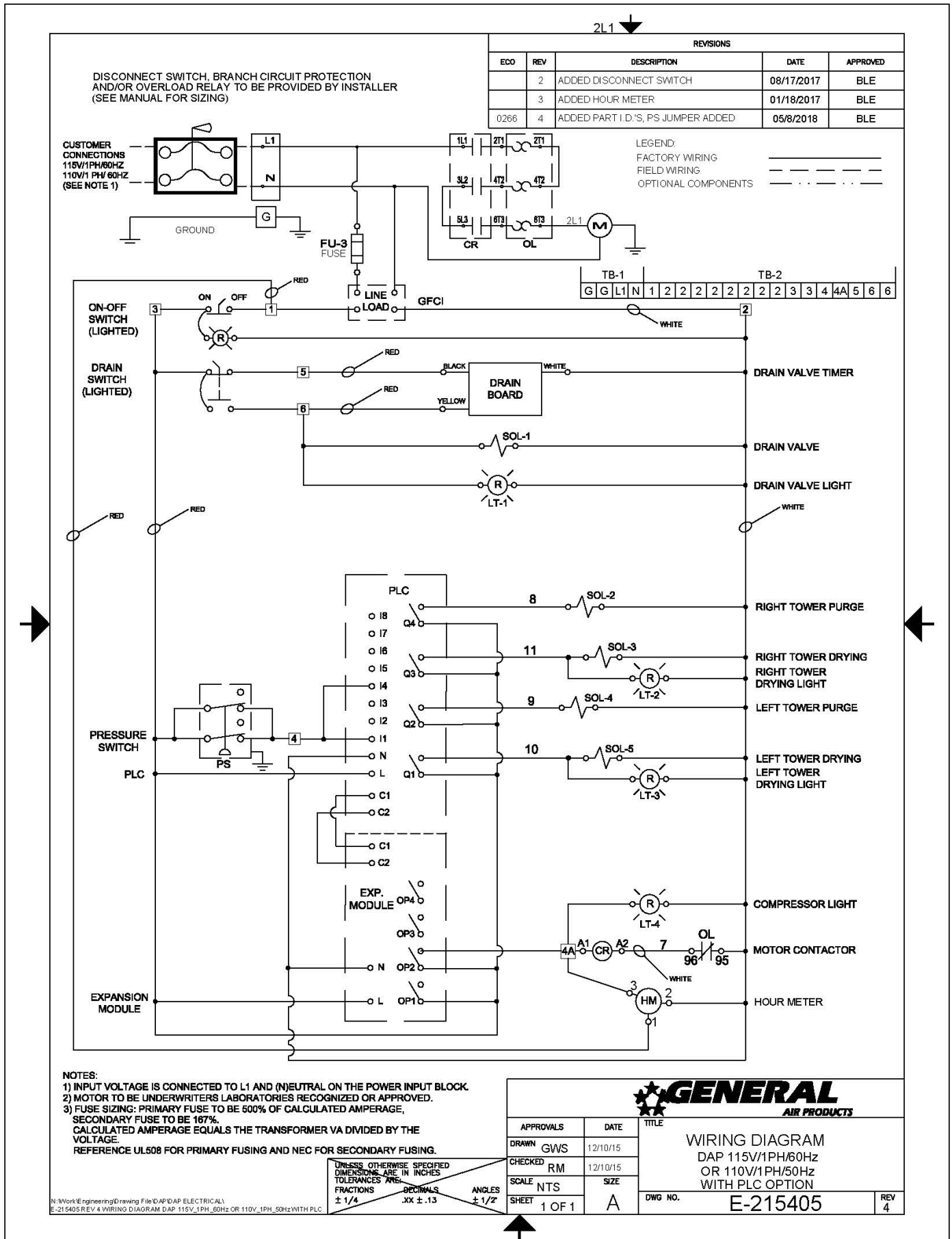

Section 9 - Dry Air Pac Electrical Schematics

9.3 Electrical Schematic - Single Phase, 208-230v/60hz or 220v/50hz

DISCONNECT SWITCH, BRANCH CIRCUIT PROTECTION AND/OR OVERLOAD RELAY TO BE PROVIDED BY INSTALLER (SEE MANUAL FOR SIZING)

REVISIONS				
ECO	REV	DESCRIPTION	DATE	APPROVED
	2	ADDED DISCONNECT SWITCH	08/17/2017	BLE
	3	ADDED HOUR METER	01/18/2017	BLE
0286	4	ADDED PART I.D.'S, ADDED PS JUMPERS	05/8/2018	BLE

CUSTOMER CONNECTIONS
208/230V/1PH/60HZ
220V/1PH/50HZ
(SEE NOTE 1)

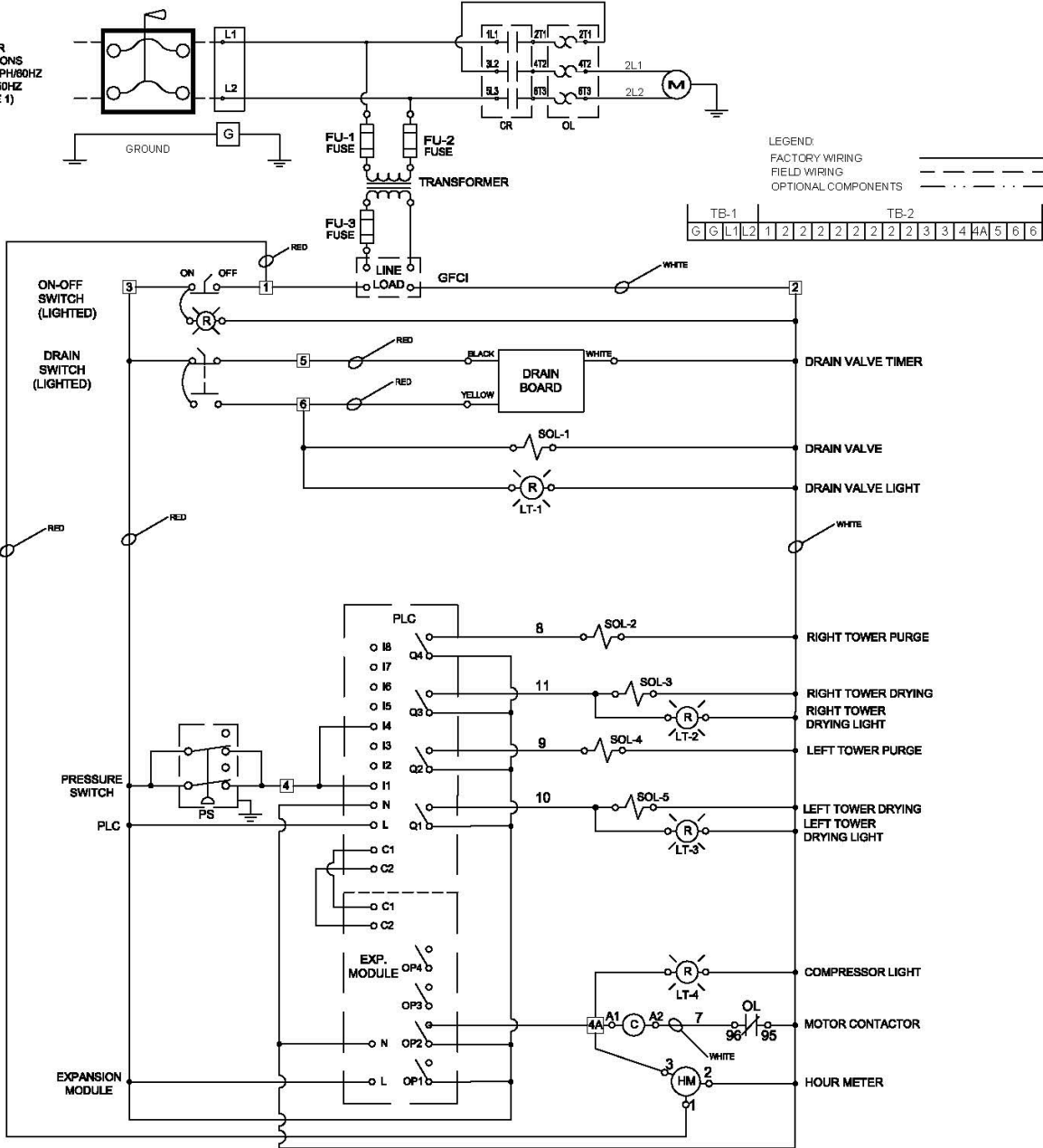

LEGEND:
FACTORY WIRING
FIELD WIRING
OPTIONAL COMPONENTS

TB-1		TB-2																
G	G	L1	L2	1	2	2	2	2	2	2	2	3	3	4	4A	5	6	6

- NOTES:
 1) INPUT VOLTAGE IS CONNECTED TO L1 AND L2 CONNECTIONS ON THE POWER INPUT BLOCK.
 2) TRANSFORMER CONNECTIONS ARE DETERMINED BY SUPPLY VOLTAGE.
 3) #3NO, #4NO ON 208/1, 13NO, 14NO ON 230/1.
 4) MOTOR TO BE UNDERWRITERS LABORATORIES RECOGNIZED OR APPROVED.
 5) FUSE SIZING: PRIMARY FUSE TO BE 800% OF CALCULATED AMPERAGE, SECONDARY FUSE TO BE 187%
 CALCULATED AMPERAGE EQUALS THE TRANSFORMER VA DIVIDED BY THE VOLTAGE. REFERENCE UL508 FOR PRIMARY FUSING AND NEC FOR SECONDARY FUSING.

UNLESS OTHERWISE SPECIFIED
DIMENSIONS ARE IN INCHES
TOLERANCES ARE:
FRACTIONS ± 1/4
DECIMALS .XX ± .13
ANGLES ± 1/2"

DAP/DAP ELECTRICAL

GENERAL AIR PRODUCTS

APPROVALS	DATE	TITLE
DRAWN GWS	12/10/15	WIRING DIAGRAM DAP 208V/230V/1PH/60Hz & 220V/1PH/50Hz WITH PLC OPTION
CHECKED RM	12/10/15	
SCALE NTS	SIZE	DWG NO. E-215406
SHEET 1 OF 1	A	REV 4

Section 10- Dry Air Pac P & ID Diagram

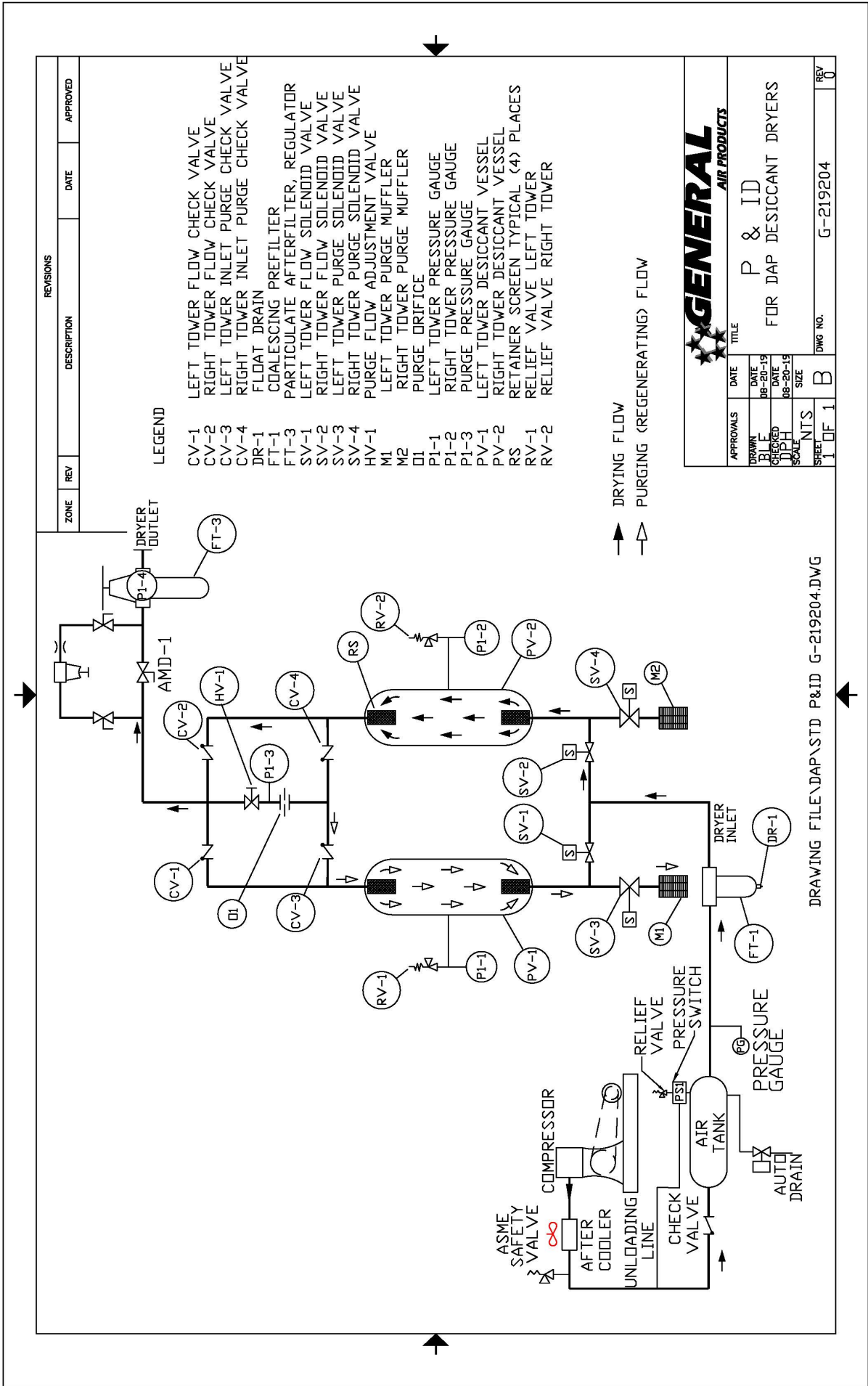

Section 10 - Warranty Policy

GENERAL PROVISIONS & LIMITATIONS

General Air Products, Inc. (the "Company") warrants to each original purchaser ("Purchaser") of its new products from the Company or its Authorized Distributor that such products are, at the time of delivery to the Purchaser, made with good materials and workmanship. No warranty is made with respect to:

1. Any product, which has been repaired or altered in such a way, in the Companies judgment, as to affect the product adversely.
2. Any product, which has, in the Companies judgment been subjected to negligence, accident, improper storage, improper installation or application.
3. Any product, which has not been operated or maintained in accordance with the recommendations of the Company.
4. Components or accessories manufactured, warranted and serviced by others.
5. Any reconditioned or prior owned product.

Claims for items described in 4. above should be submitted directly to the manufacturer.

WARRANTY PERIOD

The Company's obligation under this Warranty is limited to repair or, at its option, replacing during normal business hours at the designated facility of the Company, any part that in its judgment proved not to be as warranted within the applicable Warranty Period as follows.

COMPONENTS

All non-consumable components are warranted for 12 months from the date of purchase. Consumables are not covered under warranty. The unit must have been installed by either a factory authorized distributor or agent in accordance with the factory recommendations taking into account all other local site conditions not originally noted to the factory. The unit must be operated and maintained in accordance with the Factory recommendations and original design conditions. Failure to provide such proof of the above may void warranty.

LABOR TRANSPORTATION & INSPECTION

The Company will repair or replace any product or part thereof which in the Companies judgment is proved to be not as warranted. Labor costs are not covered under warranty.

All costs of transportation of product, labor or parts claimed not to be as warranted and, of repaired or replaced parts to or from factory shall be borne by purchaser. The Company may require the return of any part claimed not to be as warranted to one of its facilities as designated by the Company, transportation prepaid by Purchaser, to establish a claim under this warranty.

Replacement parts provided under the terms of the warranty are warranted for the remainder of the Warranty Period of the product upon which installed to the same extent as if such parts were original components.

DISCLAIMER

THE FOREGOING WARRANTY IS EXCLUSIVE AND IT IS EXPRESSLY AGREED THAT, EXCEPT AS TO TITLE, THE COMPANY MAKES NO OTHER WARRANTIES, EXPRESSED OR IMPLIED OR STATUTORY, INCLUDING ANY IMPLIED WARRANTY OR MERCHANTABILITY.

THE REMEDY PROVIDED UNDER THIS WARRANTY SHALL BE THE SOLE, EXCLUSIVE AND ONLY REMEDY AVAILABLE TO THE PURCHASER AND IN NO CASE SHALL THE COMPANY BE SUBJECT TO ANY OTHER OBLIGATIONS OR LIABILITIES. UNDER NO CIRCUMSTANCES SHALL THE COMPANY BE LIABLE FOR SPECIAL, INDIRECT, INCIDENTAL OR CONSEQUENTIAL DAMAGES, EXPENSES, LOSSES OR DELAYS HOWSOEVER CAUSED.

No statement, representation, agreement, or understanding, oral or written, made by any agent, distributor, representative or employee of the Company which is not contained in this Warranty will be binding upon the company unless made in writing and executed by an officer of the Company.

This warranty shall not be effective as to any claim which is not presented within 30 days after the date upon which the product is claimed not to have been as warranted. Any action for breach of this warranty must be commenced within one year after the date upon which the cause of action occurred.

Any adjustment made pursuant to this warranty shall not be construed as an admission by the Company that any product was not as warranted.

PROMPT DISPOSITION & RETURNS POLICY

The Company will make a good faith effort for prompt correction or other adjustment with respect to any product, which proves to be defective within the warranty period. Before returning any product, write or call the distributor, agent or authorized company from which the product was purchased, describing defect and giving date and number of original invoice, a well as proof of Factory supplied consumables and proof of scheduled maintenance. No products will be accepted for return without the Company issuing a "Returned Goods Authorization" (RGA) to the Purchaser and unless accompanied by a properly authorized RGA request form initiated by the Purchaser. Return freight must be prepaid and each returned product must have the RGA number clearly marked on the product. Title and risk of loss pass to buyer upon delivery to the common carrier.

PRODUCT SUITABILITY

Many States, Localities and Countries have codes and regulations governing sales, construction, installation, and/or use of products for certain purposes, which may vary from those in neighboring areas. While General Air Products, Inc. attempts to assure that its products comply with such codes, it cannot guarantee compliance, and cannot be responsible for how the product is installed or used? Before purchase and use of a product, please review the product application, and national and local codes and regulations, and be sure that the product, installation, and use will comply with them.

General Air Products, Inc.

118 Summit Drive
Exton, PA 19341
P: 610-524-8950
F: 610-524-8965

REV:4/22/11