

Econo RFP System

Residential Fire Protection Pump

Our Econo Series RFP Systems offer the bare essentials for what is needed in a residential fire sprinkler system pump when considering ease of installation and performance demands. The Econo RFP System is designed to provide all 13D required features and functionality at the lowest possible cost without compromising the high level of quality the industry has come to expect from General Air Products.

As with all of the RFP Systems, the Econo consists of a stainless steel pump, all non-ferrous components and an industrial duty, digital pressure switch. The Econo RFP System differs from the rest of our 13D Pump line in that it doesn't consist of much more than that. This is how we ensure the lowest possible cost to fit projects with tight budgets.



- **Stainless Steel Pump**
- **Locking Ball Valve**
- **All Non-Ferrous Components**
- **Water Hammer Arrestor**
- **New Digital Pressure Switch**
- **Check Valve**
- **Water Delivery Pressure Gauge**
- **Drain Valve**
- **Lifetime Customer Service & Technical Support**

★ American Built Digital Pressure Switch Now Standard On All Models ★

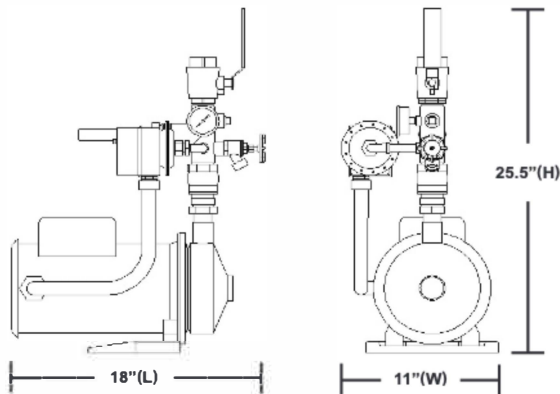

Model Number	AMP Draw	Weight (lbs)
XPS11	5.2	49
XPS14	9.1	70
XPS15	9.1	70
XPS18	11.2	77
XPS19	12.8	77
XPS23	23.7	80

Standard RFP Systems are: 230V / 1Ph / 60Hz.

Use the chart below to select the correct unit for your application. **Consult factory for confirmation of best selection.**
Example: Your system has a flow of 30 gallons per minute (GPM) at 45 PSI - the correct selection would be an XPS18.

PSI	Feet of Head	Flow (GPM)								
		20	25	30	35	40	45	50	55	60
25	58	XPS11	XPS14	XPS14	XPS14	XPS15	XPS18	XPS18	XPS18	XPS18
30	69	XPS14	XPS14	XPS14	XPS14	XPS15	XPS18	XPS18	XPS18	XPS18
35	81	XPS14	XPS14	XPS14	XPS14	XPS18	XPS18	XPS18	XPS18	XPS19
40	92	XPS14	XPS14	XPS18	XPS18	XPS18	XPS18	XPS18	XPS19	XPS19
45	104	XPS14	XPS14	XPS18	XPS18	XPS18	XPS19	XPS19	XPS19	XPS19
50	116	XPS18	XPS18	XPS18	XPS18	XPS19	XPS19	XPS19	XPS23	XPS23
55	127	XPS18	XPS18	XPS19	XPS19	XPS19	XPS19	XPS19	XPS23	XPS23
60	139	XPS19	XPS19	XPS19	XPS19	XPS23	XPS23	XPS23	XPS23	XPS23

All information is subject to change without notice. Consult Factory for most up-to-date product details.

⚠ WARNING: Cancer and Reproductive Harm - www.p65warnings.ca.gov