

REVISIONS				
ECO	REV	DESCRIPTION	DATE	APPROVED
0149	3	REDRAWN IS SW, INSTALL SAFETY VALVE	10/02/17	DPH
0509	4	ADD 575 VOLTAGE	05/01/20	DPH

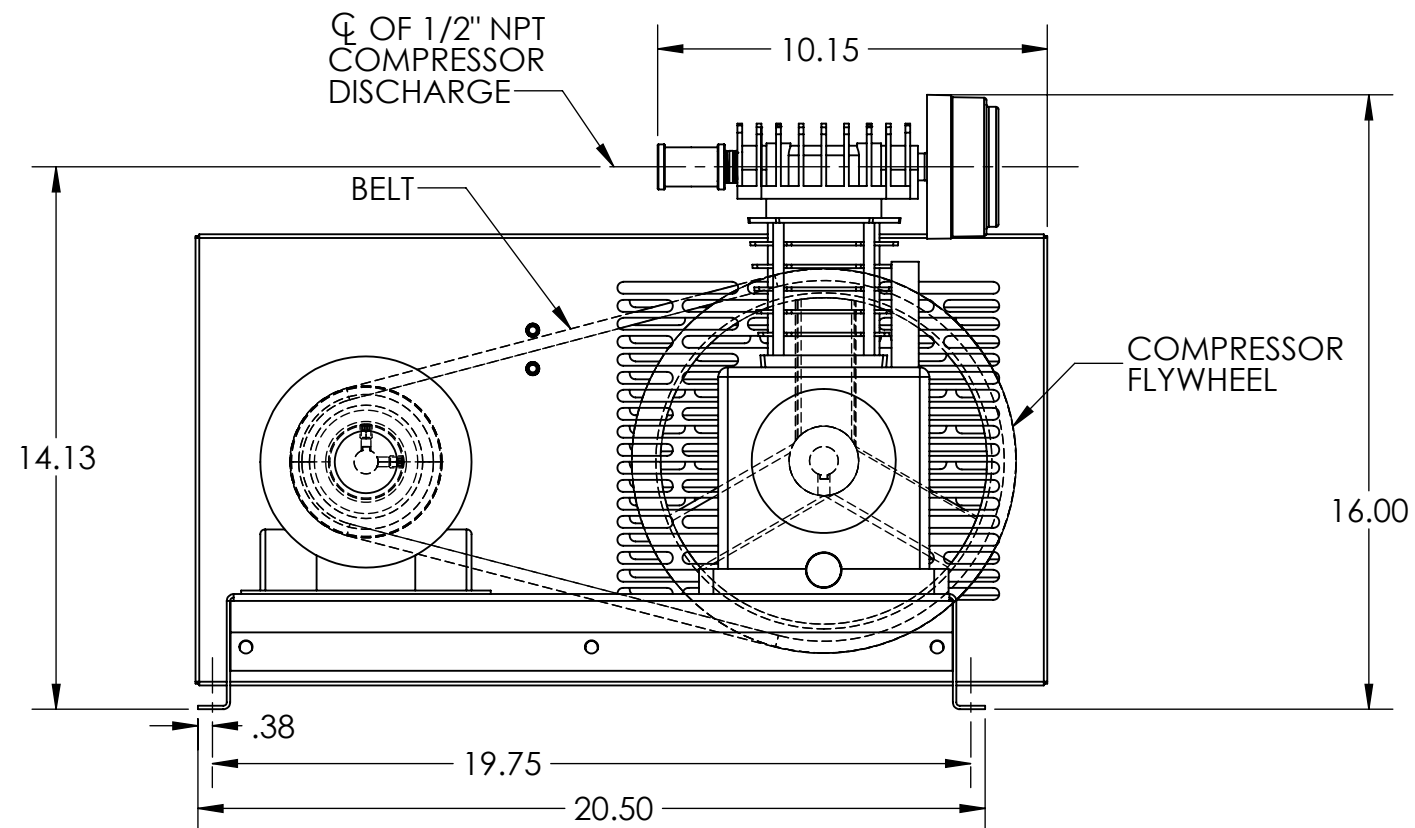
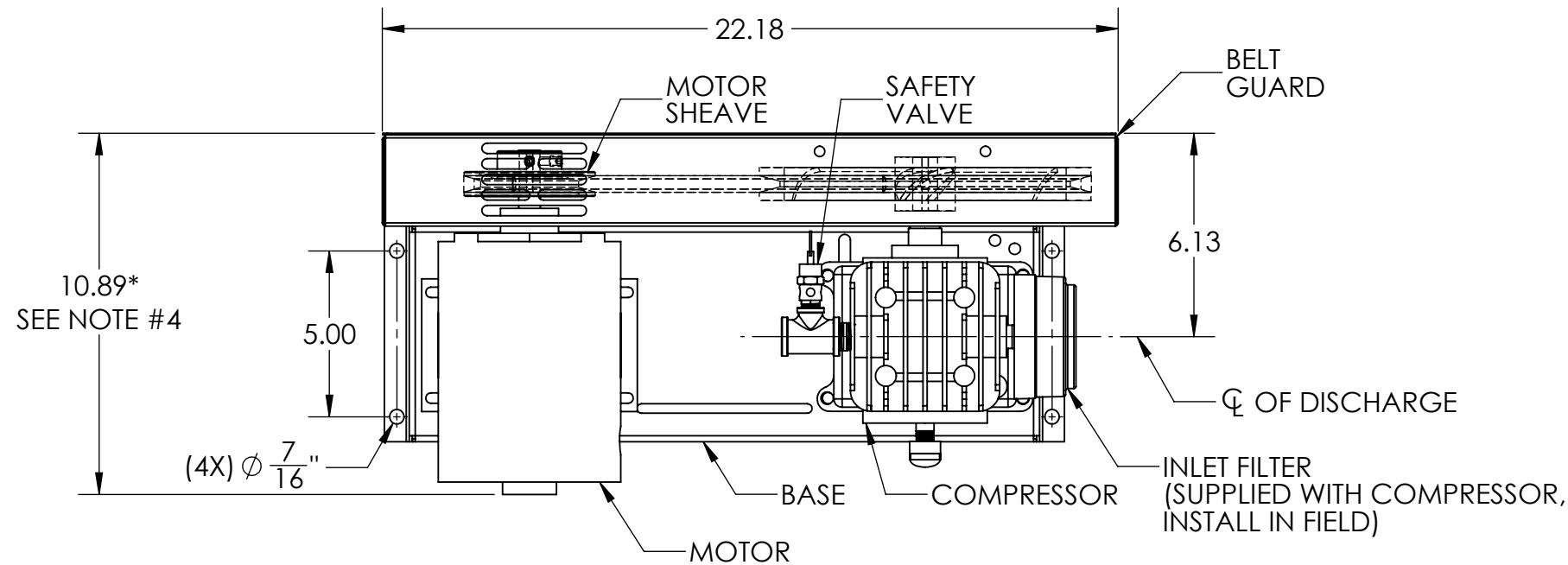

NOTES:

1. THIS DRAWING REPRESENTS MULTIPLE ASSEMBLIES. SEE TABLE BELOW FOR MODELS REPRESENTED.
2. REFERENCE INDIVIDUAL PARTS LISTS FOR COMPONENT PART NUMBERS.
3. REFERENCE INSTRUCTION MANUAL FOR INSTALLTION AND WIRING RECOMMENDATIONS.
4. *DIMENSION MAY VARY BY MODEL NUMBER.

MODEL NUMBER	VOLTAGE
L425100A	115/208-230V/60HZ/1PH
L425100A-50	110/220V/50HZ/1PH
L425100B	230/460V/60HZ/3PH
L425100B-50	190/380V/50HZ/3PH
L425100B-5	575V/60HZ/3PH

N:\Work\Engineering\Drawing File\COMPRESSORS\BASE MOUNT LUBRICATED COMPRESSORS\G-200073 REV 4 GA L425100 BASE MT

UNLESS OTHERWISE SPECIFIED DIMENSIONS ARE IN INCHES TOLERANCES ARE:

FRACTIONS	DECIMALS	ANGLES
±1/2	.xx±.50	±1°

THIS DRAWING AND ALL OF ITS CONTENTS ARE THE SOLE PROPERTY OF GENERAL AIR PRODUCTS, INC. DETAILS MAY CHANGE WITHOUT NOTICE. THE CONTENTS OF THIS DRAWING, MAY NOT BE REPRODUCED OR INCORPORATED IN WHOLE OR IN PART IN ANY EQUIPMENT, NOR THE MANUFACTURE OF ANY PARTS, WITHOUT WRITTEN CONSENT OF GENERAL AIR PRODUCTS, INCORPORATED.

APPROVALS	DATE	TITLE:
DRAWN WLW	10/2/2017	GENERAL ARRANGEMENT 1 HORSEPOWER BASE MOUNTED LUBRICATED COMPRESSORS
CHECKED DPH	10/2/2017	
SCALE	SIZE	
NONE SHEET 1 OF 1	B	
DWG. NO.		REV
G-200073		4