

REVISIONS				
ECO	REV	DESCRIPTION	DATE	APPROVED
0149	4	REDRAWN IS SW, INSTALL SAFETY VALVE	10/02/17	DPH
0509	5	ADD 575 VOLTAGE	05/01/20	DPH

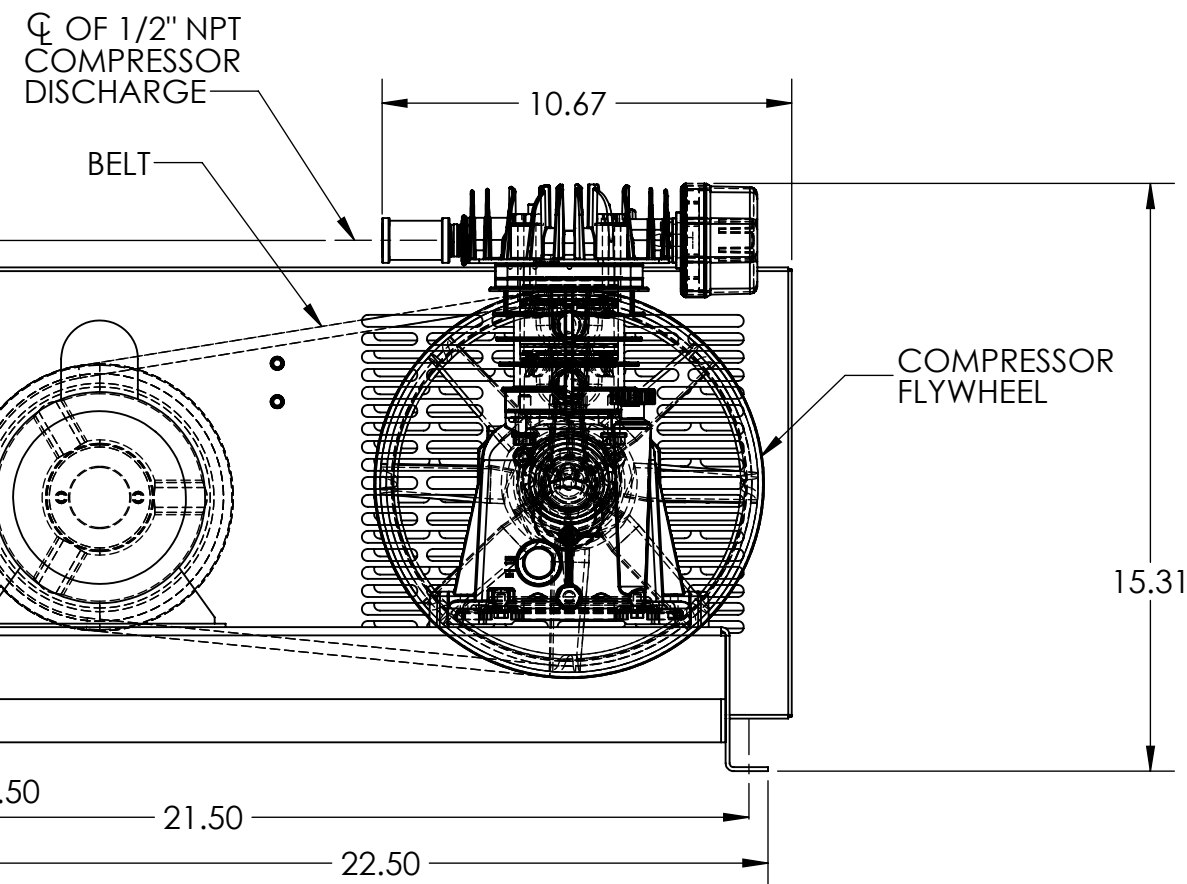
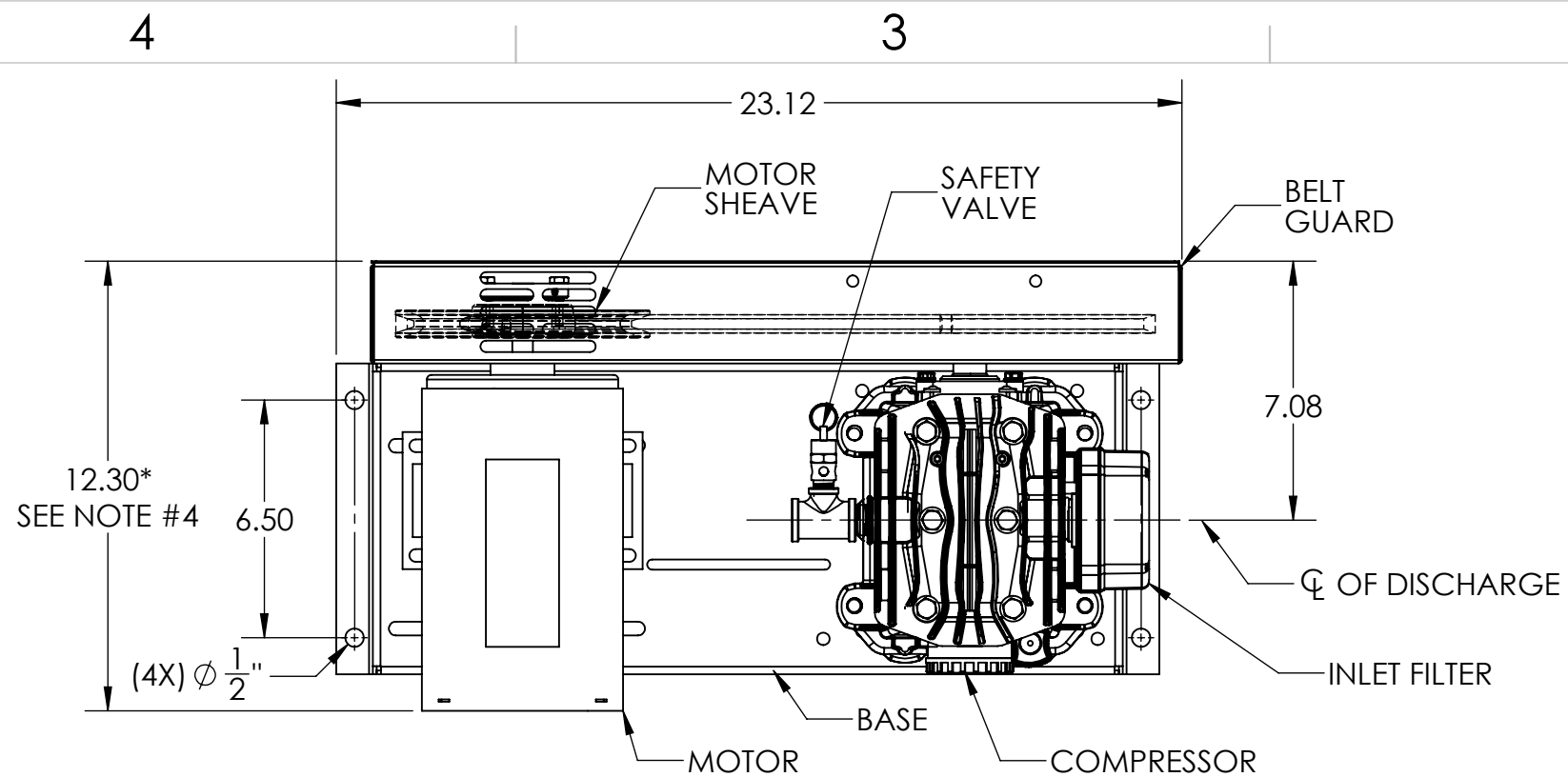

NOTES:

1. THIS DRAWING REPRESENTS MULTIPLE ASSEMBLIES. SEE TABLE BELOW FOR MODELS REPRESENTED.
2. REFERENCE INDIVIDUAL PARTS LISTS FOR COMPONENT PART NUMBERS.
3. REFERENCE INSTRUCTION MANUAL FOR INSTALLTION AND WIRING RECOMMENDATIONS.
4. *DIMENSION MAY VARY BY MODEL NUMBER.

MODEL NUMBER	VOLTAGE
L900150A	115/208-230V/60HZ/1PH
L900150A-HP	115/208-230V/60HZ/1PH
L900150A-50	110/220V/50HZ/1PH
L900150B	208-230/460V/60HZ/3PH
L900150B-HP	208-230/460V/60HZ/3PH
L900150B-50	220/380/440V/50HZ/3PH
L900150B-5	575V/60HZ/3PH

N:\Work\Engineering\Drawing File\COMPRESSORS\BASE MOUNT LUBRICATED COMPRESSORS\
G-200075 REV 5 GA L900150 BASE MT

UNLESS OTHERWISE SPECIFIED
DIMENSIONS ARE IN INCHES
TOLERANCES ARE:
FRACTIONS DECIMALS ANGLES
 $\pm 1/2$.xx $\pm .50$ $\pm 1^\circ$

THIS DRAWING AND ALL OF ITS CONTENTS ARE THE SOLE
PROPERTY OF GENERAL AIR PRODUCTS, INC. DETAILS MAY
CHANGE WITHOUT NOTICE. THE CONTENTS OF THIS
DRAWING, MAY NOT BE REPRODUCED OR INCORPORATED
IN WHOLE OR IN PART IN ANY EQUIPMENT, NOR THE
MANUFACTURE OF ANY PARTS, WITHOUT WRITTEN
CONSENT OF GENERAL AIR PRODUCTS, INCORPORATED.

GENERAL
AIR PRODUCTS

APPROVALS	DATE	TITLE:
DRAWN WLW	10/2/2017	GENERAL ARRANGEMENT 1 1/2 HORSEPOWER BASE MOUNTED LUBRICATED COMPRESSORS
CHECKED DPH	10/2/2017	
SCALE	SIZE	
NONE SHEET 1 OF 1	B	
DWG. NO.		REV
G-200075		5