

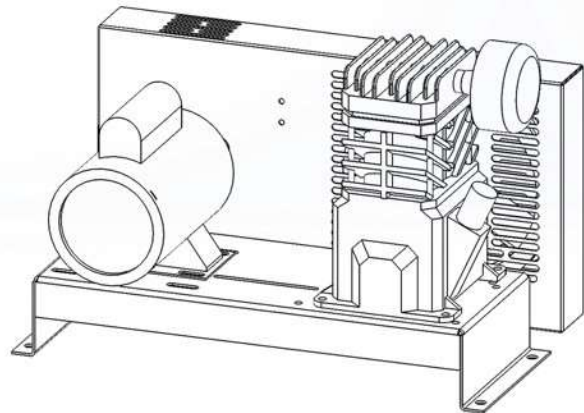

# L & LT Series

Base and Tank Mounted Lubricated Air Compressors

## Installation, Operation and Maintenance Manual

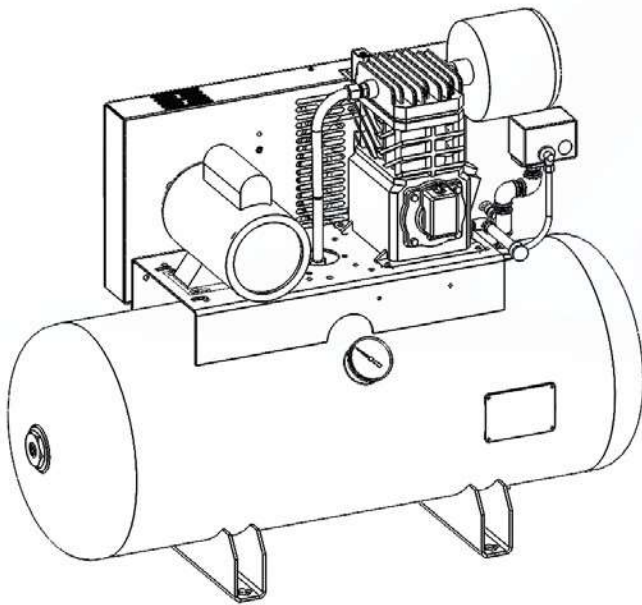

Call **1-800-345-8207**  
or visit our web site for our complete product listing  
**[www.GeneralAirProducts.com](http://www.GeneralAirProducts.com)**

 **WARNING**

This product can expose you to chemicals including Cumene, which is known to the State of California to cause cancer and birth defects or other reproductive harm. For more information go to [www.P65Warnings.ca.gov](http://www.P65Warnings.ca.gov)

# Table of Contents

## Section 1 - Safety & Warnings

- 1.1 Safety Guidelines
- 1.2 General Safety Information
- 1.3 Safety Notes

## Section 2 - Receiving

## Section 3 - Installation Location

## Section 4 - Mounting

## Section 5 - Lubrication

## Section 6 - Piping

- 6.1 - Piping Instructions
- 6.2 - L Series Base Mounted Lubricated Compressor Installation Drawing
- 6.3 - LT Series Tank Mounted Lubricated Compressor Installation Drawing

## Section 7 - Wiring

- 7.1 - Wiring Instructions
- 7.2 - Lubricated Compressor Single & 3 Phase Wiring Drawing (IEC Version)
- 7.3 - Lubricated Compressor Single & 3 Phase Wiring Drawing (NEMA Version)

## Section 8 - Maintenance Instructions

## Section 9 - Troubleshooting Guide

## Section 10 - Warranty Policy

If there are any questions regarding installation, operation, or maintenance of this compressor, please call 800-345-8207

**IMPORTANT: ALL INFORMATION SUBJECT TO CHANGE WITHOUT NOTICE.  
Consult factory for the most up to date version of this manual - 1-800-345-8207.**

# Section 1 - Safety & Warnings

---

## 1.1 Safety Guidelines

This manual contains information that is very important to know and understand. This information is provided for SAFETY and to PREVENT EQUIPMENT PROBLEMS. To help recognize this information, observe the following symbols.



**DANGER**

*Danger indicates an imminently hazardous situation which, if not avoided, WILL result in death or serious injury.*



**WARNING**

*Warning indicates a potentially hazardous situation which, if not avoided COULD result in death or serious injury.*



**CAUTION**

*Caution indicates a potentially hazardous situation which, if not avoided, MAY result in minor or moderate injury.*



**NOTICE**

*Notice indicates important information, that if not followed may cause damage to equipment.*

## 1.2 General Safety Information

1. Read all manuals included with this product carefully. Be thoroughly familiar with the controls and the proper use of the equipment
2. Follow all local electrical and safety codes as well as National Electrical Codes (NEC), Occupational Safety and Health Act (OSHA), and National Fire Protection Association (NFPA)
3. Only persons familiar with these rules of safe operation should be allowed to use the equipment.
4. Keep visitors away and NEVER allow children in the work area.
5. Wear safety glasses and use hearing protection when operating the unit.
6. Do not stand on or use the unit as a handhold.
7. **Periodic inspection and test of this equipment is required.** Consult your installer and local codes to meet all requirements.
8. Check all fasteners at frequent intervals for proper tightness.

## 1.3 Safety Notes



**DANGER**

- This compressor is not equipped and should NOT be used "as is" to supply breathing quality air.



**WARNING**

- Motors, electrical equipment and controls can cause electrical arcs that will ignite flammable gas or vapor. Never operate or repair in or near flammable gas or vapor. Never store flammable liquids or gasses near the compressor.



**WARNING**

- These compressors are suitable for pumping only atmospheric air. As defined in Compressed Gas Association Pamphlet G-7, page 3, atmospheric air is a mixture of elements and compounds where nitrogen and oxygen comprise more than 99% with all other trace gasses comprising less than 1%. **Do not use this compressor in contaminated environments or for pumping mixtures other than atmospheric air.**



**WARNING**

- Compressed air contains liquid water and is saturated with water vapor, which can freeze when surrounding temperatures are lower than 32°F (0°C). Component selection to minimize the effects of water vapor must be considered.

## Section 2 - Receiving

---

Your compressor is inspected at the factory and packaged to protect against shipping damage. When the compressor is unpacked, inspect for damage or missing parts. All claims should be settled directly with the freight company.



- Do not operate this compressor if damaged during shipment, handling or use. Any damage may result in failure and cause injury or property damage.

## Section 3 - Installation Location

---

Locate the compressor in a clean, well ventilated area where air is relatively cool, clean and dry. A 110°F (35°C) maximum and 40°F (4.5°C) minimum temperature for surrounding and inlet air are recommended. Provide at least 12 to 18 inches of clearance from any wall or other obstruction that will interfere with airflow through the flywheel. The flywheel is located inside the belt guard. Blocking airflow through the flywheel may cause the compressor to over heat. Do not place the compressor in an area of excessive heat, such as near a boiler.



- DO NOT connect compressor intake to freezer room. Call 800-345-8207 for more information.

## Section 4 - Mounting

---

The compressor must be mounted to a firm level base. Permanent installations should be bolted to the base using the bolt holes provided. Always shim the unit level before bolting it to the floor. Vibration isolators (Part #: KVP4X4) are included with each compressor. When using vibration isolator pads, do not draw bolts tight. Allow the pads to absorb vibrations. It is recommended that the supplied flexible hose (Part #: P3002MP) be installed between the compressor and service piping to reduce vibration and the likelihood of damage to the compressor.

## Section 5 - Lubrication

---

All tank models and all base models L620 and larger are shipped filled with specially formulated compressor oil (part #: APC01Q). Spare oil is shipped in a marked container. This oil should be used to replace any oil lost in shipping and for maintenance oil changes. Do not overfill the oil reservoir. Over-filling the reservoir will result in oil leaking from the reservoir breather during operation.

Model Number	Oil Volume
L(T)20033	8 ounces
L(T)29050	8 ounces
L(T)36575	12 ounces
L(T)425100	12 ounces
L(T)620100	17 ounces
L(T)900150	17 ounces
L(T)1220200	8.5 ounces
L(T)1300300	8.5 ounces
L(T)1600300	1 1/2 quarts
L(T)2000500	1 1/2 quarts
L(T)2500500	1 1/2 quarts

Base models L200 to L425 are not filled with oil for shipment. Use the oil shipped with these compressors to fill until sight glass is 1/2 to 2/3 full. Run compressor briefly, recheck oil level and adjust if needed.



- Some compressors are shipped with oil. **Check oil level before operation.**



- All lubricated compressors have an oil site glass. Oil should be filled until the sight glass is 1/2 to 2/3 full.

## Section 6 - Piping

---

### 6.1 Piping Instructions



- Compressed air contains liquid water and is saturated with water vapor, which can freeze when surrounding temperatures are lower than 32°F (0°C). Component selection to minimize the effects of water vapor must be considered.

#### 6.1.1 - All Lubricated Compressors:

Piping between the compressor, accessory items and the sprinkler system should be at least 1/2" internal diameter to minimize pressure drop from the compressor to the system. Larger pipe size may be required by code and may be substituted with no adverse effects. Smaller pipe size must not be used. Smaller pipe size will restrict the compressor flow, lowering capacity and cause the compressor / motor to work harder which shortens the compressor / motor life. All piping connected to the compressor must be fully supported and not transfer any loads to the compressor.

The compressor outlet piping should contain an accessible drain. As a minimum a manual drain may be used, but an automatic drain (Part #: CDF2000) is recommended to remove excess water.

#### 6.1.2 - On Base Mounted Units (L Series):

If an AMD-2 (General Air Products model air maintenance device) is used to operate the compressor motor, allow sufficient distance between the compressor and AMD-2 to ensure that the maximum temperature at the AMD-2 is 200°F or less. The relief valve shipped with each unit must be installed between the compressor and AMD-2.

General Air Products recommends that all compressors 2 HP and larger are tank mounted. Failure to either tank mount these compressors or to install according to the installation drawing (Section 6.2 of this manual), will cause overpressure of the compressor and cause overheating of the motor.



- Failure to install a relief valve between the compressor and AMD can cause over pressure of the compressor and blown head gaskets.

#### 6.1.3 - On Tank Mounted Units (LT Series):

A relief valve is mounted on the compressor's tank. This valve will open at a preset value above the pressure switch setting to prevent excess tank pressure in the event of switch failure.

If an AMD-1 (General Air Products model air maintenance device) is used, allow sufficient distance between the compressor and AMD-1 to ensure that the maximum at the AMD-1 is 200°F or less.

A manual tank drain is provided on the bottom of each tank mounted compressor. Moisture accumulated in the tank must be drained weekly. An automatic drain (Part #: CDF2000) is recommended in areas of high humidity.



- Do not attempt to change the safety relief valve setting.



- Accumulation of condensed water in the system can cause corrosion of components and reduction of system capacity.



- Warranty is void if a separate check valve is not installed to prevent water backflow to compressor.

ALL PIPING AND WIRING TO BE IN ACCORDANCE WITH APPLICABLE STATE, LOCAL AND NATIONAL CODES & SHOULD BE APPROVED BY AHJ

## BASE MOUNTED LUBRICATED COMPRESSORS INSTALLATION INSTRUCTIONS



PRESSURE SWITCH IS FACTORY SET AT 30# CUT, IN 40# CUT OUT. HIGHER PRESSURE SETTINGS MAY REQUIRE A LARGER MOTOR. CONSULT FACTORY FOR DETAILS.  
PRESSURE SWITCH MUST BE WIRED IN CIRCUIT TO CONTROL COMPRESSOR.

CONNECT TO REQUIRED SYSTEM TRIM

MULTIPLE CHECK VALVES IN FEED LINES CAN RESULT IN LOWER SYSTEM PRESSURES DUE TO PRESSURE DROPS

IF SYSTEM IS FEEDING FREEZER ROOM CONSULT FACTORY FOR DRY AIR PAC INFORMATION.

200 F MAX.

P/N AMD-2 AIR MAINTENANCE DEVICE WITH BUILT IN PRESSURE SWITCH.

1/2" MINIMUM (LARGER IF REQUIRED BY CODE)

FIELD PIPING - SUFFICIENT LENGTH OF PIPING MUST BE USED TO ENSURE MAXIMUM TEMPERATURE OF 200 DEG. F AT THE AIR MAINTENANCE DEVICE OR FAILURES WILL OCCUR.

BELTGUARD AFTERCOOLER RECOMMENDED IF SHORT PIPE RUNS ARE USED.

MOST MOTORS ARE MULTIPLE VOLTAGE. CHECK NAMEPLATE AND VERIFY CORRECT INTERNAL CONNECTIONS FOR VOLTAGE BEING SUPPLIED TO UNIT.

MAGNETIC STARTER RECOMMENDED (CONSULT APPLICABLE CODES)

30" FLEX HOSE SUPPLIED WITH COMPRESSOR

SAFETY VALVE

**WARNING!**  
DO NOT INSTALL IN AREAS EXPOSED TO TEMPERATURES BELOW 40 DEGREES F. OR AREAS EXPOSED TO WEATHER. CONSULT FACTORY FOR WEATHERPROOF OPTIONS.

INSTALL ALLOWING EASY ACCESS TO BELTGUARD FOR MAINTENANCE CHECKS. 12" CLEARANCE IN FRONT AND BEHIND BELTGUARD REQUIRED

MANUAL DRAIN RECOMMENDED AS MINIMUM.

OR

AUTOMATIC DRAIN (P/N FD-1) RECOMMENDED ON DRIP LEG TO REMOVE EXCESS WATER ACCUMULATION.

NOTE: L20033 TO L425100 ARE SHIPPED WITHOUT OIL INSTALLED. ADD OIL (P/N APC01Q) BEFORE OPERATING

ALL COMPRESSORS, 2 HP AND LARGER, SHOULD BE TANK MOUNTED OR PIPED IN ACCORDANCE WITH THESE INSTALLATION INSTRUCTIONS.

VIBRATION ISOLATORS SUPPLIED WITH COMPRESSOR

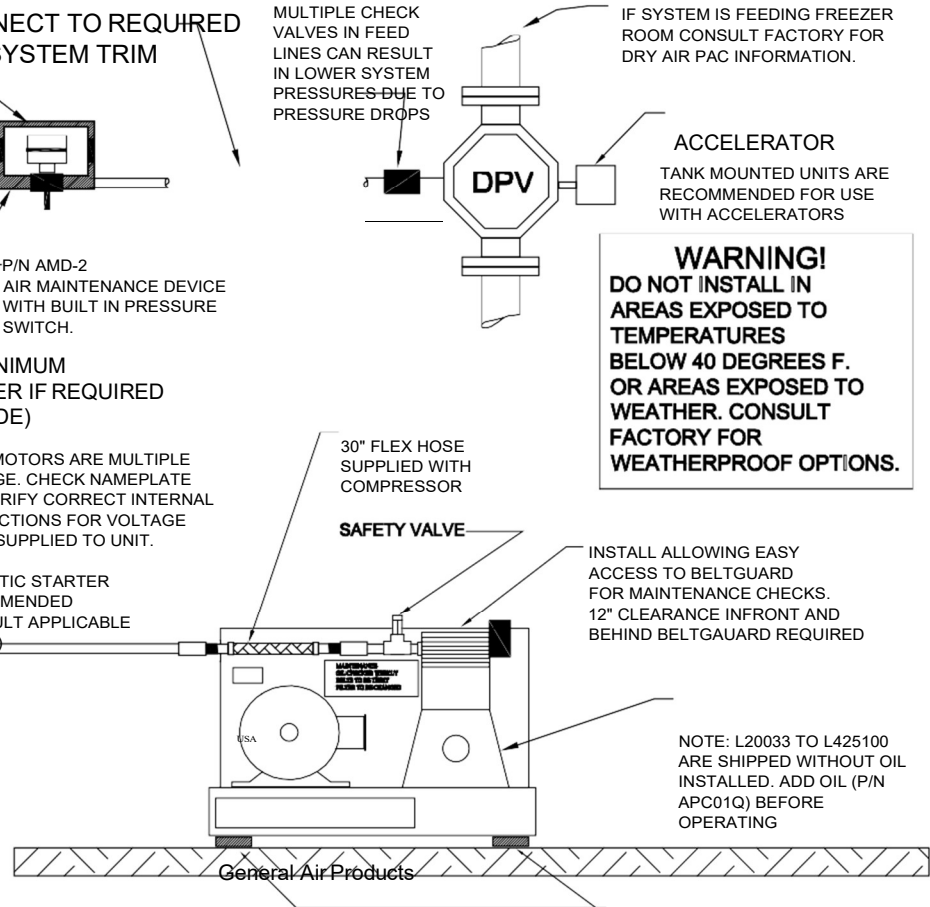

# Section 6 - Piping

## 6.3 LT Series Tank Mounted Lubricated Compressor Installation Drawing

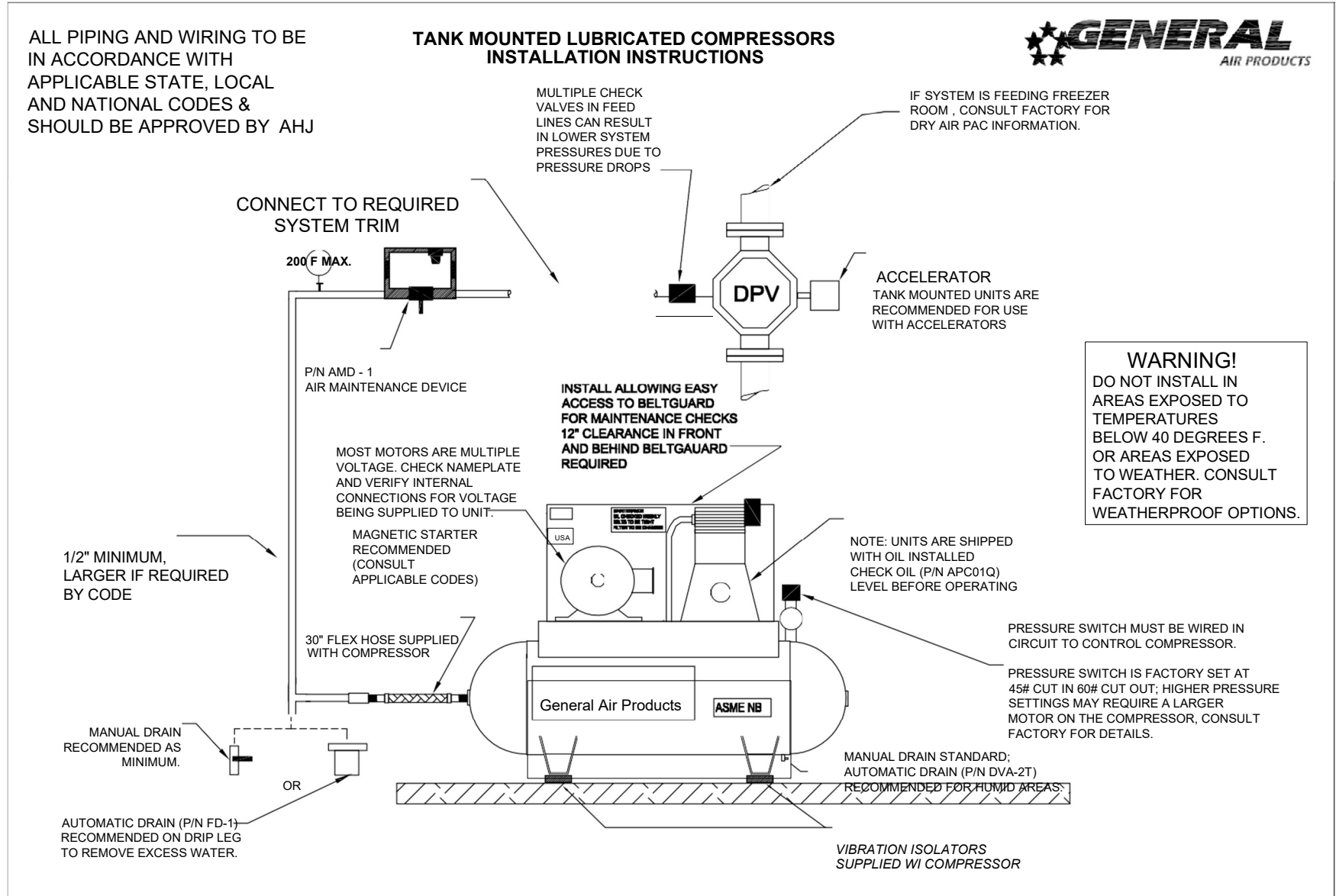

PART NUMBERS LISTED ARE FOR ACCESSORY ITEMS RECOMMENDED FOR COMPLETE INSTALLATION - CONSULT YOUR LOCAL DISTRIBUTOR FOR AVAILABILITY

TNKIS (03/16/18)

# Section 7 - Wiring

## 7.1 Wiring Instructions



- Wiring should be in accordance with the national electrical code and any local codes or regulations. Have a competent electrician ensure that the voltage supplied matches the compressor voltage.



- Inadequate wiring size can cause insufficient voltage at the compressor during start-up. Overheating and damage can result to the motor and controls.



- Failure to use the pressure switch may result in overpressure of the compressor or other components in the system. Overpressure of the compressor can result in blown head gaskets or other damage.

The supply wire must be of adequate size and no other equipment should be connected to the same line. The table below lists the recommended wire size for each model based on a 100' run. Consult factory for longer runs.

Minimum Recommended Wire Size		
Model #	1 Phase	3 Phase
L(T)20033	10	12
L(T)29050	8	12
L(T)36575	8	12
L(T)425100	6	12
L(T)620100	6	10
L(T)900150	6	10
L(T)1220200	4	10
L(T)1300300	4	8
L(T)1600300	2	8
L(T)2000500	2	6
L(T)2500500	2	6

The motor must be wired to a pressure switch which controls starting (cut in pressure) and stopping (cut out pressure) of the motor. All single phase units 2 hp and larger and all three phase units require a motor starter with overload protection using the pressure switch to operate the starter to meet the NEC, NFPA70, Article 430 motor protection requirements.

The motors supplied are multiple voltage motors. Verify the internal motor leads are connected for the voltage being supplied to the unit. To verify or change internal voltage connections remove the cover plate located on the rear side of the motor and reconnect the wire leads as shown on the motor's wiring diagram.

An arrow on the belt guard indicates the direction of the rotation of the compressor. If the compressor rotates in the opposite direction, reverse the rotation of the motor. Direction of rotation of single phase motors is controlled by internal re-connection of the motor leads as shown on the motors nameplate. Interchanging any two incoming supply wires reverses rotation of three phase motors.

### 7.1.1 On Tank Mounted Units (LT Series):

The standard pressure switch is factory set at 45 psig cut in and 60 psig cut out. Higher settings may require a larger motor on the compressor. Consult General Air Products by calling 800-345-8207 before adjusting the pressure switch.

## Section 7 - Wiring

### Instructions to change single phase Lubricated Tank Compressors (LT) pre-wired for 115 Volts to 208-230 Volts

Pressure Switch will come with wiring intended for use in a single phase 115V circuit (Fig. 1)

#### Instructions:

1. Remove Jumpers (Fig. 2)
2. Rewire motor connections for high voltage in motor junction box. Follow motor's wiring label
3. Rewire pressure switch for high voltage (Fig. 3)
4. Connect black and white wires to motor connections on pressure switch as shown (Fig. 3)
5. Connect L1 & L2 from customers supply as shown (Fig. 3)

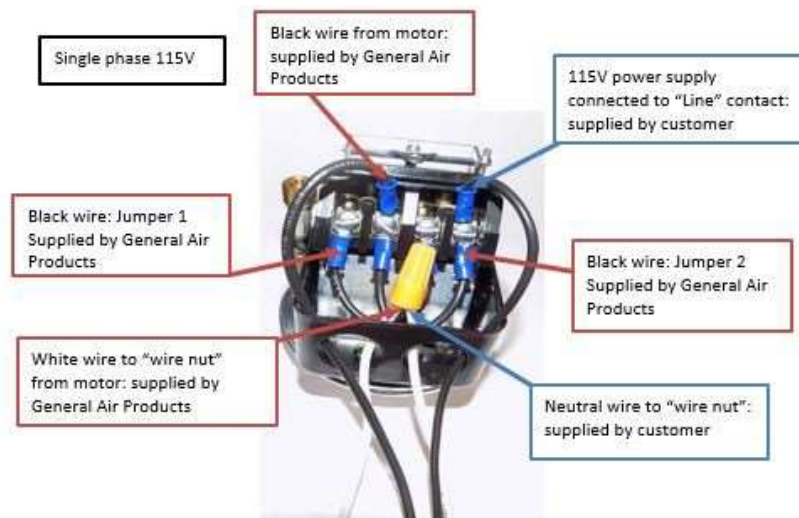

Fig. 1: Pressure switch with jumper wires connected

Remove jumper wires and place "General Air" supplied white wire on the 2nd pole of the pressure switch (shown on "Fig 3")



Fig. 2: 3" long jumper wire

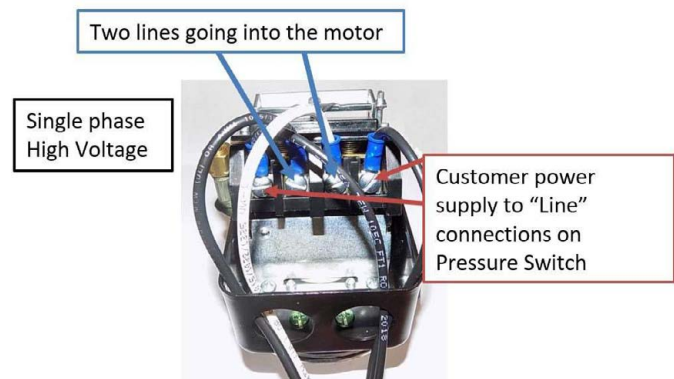
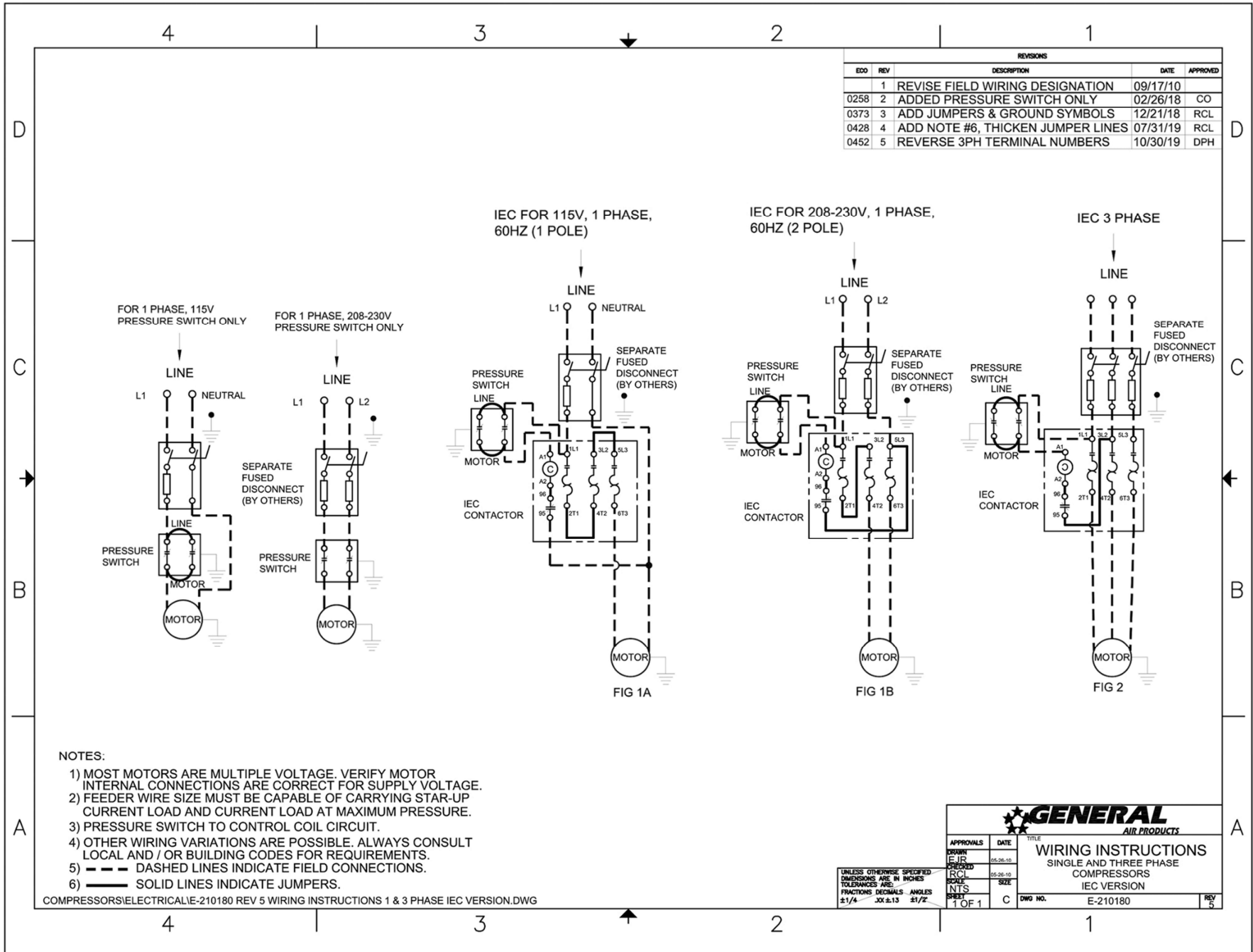

Fig. 3: Pressure switch with line labels

# Section 7 - Wiring

## 7.2 Lubricated Compressor Single & 3 Phase Wiring Drawing (IEC Version)



1-800-345-8207



# Section 7 - Wiring

## 7.3 Lubricated Compressor Single & 3 Phase Wiring Drawing (NEMA Version)

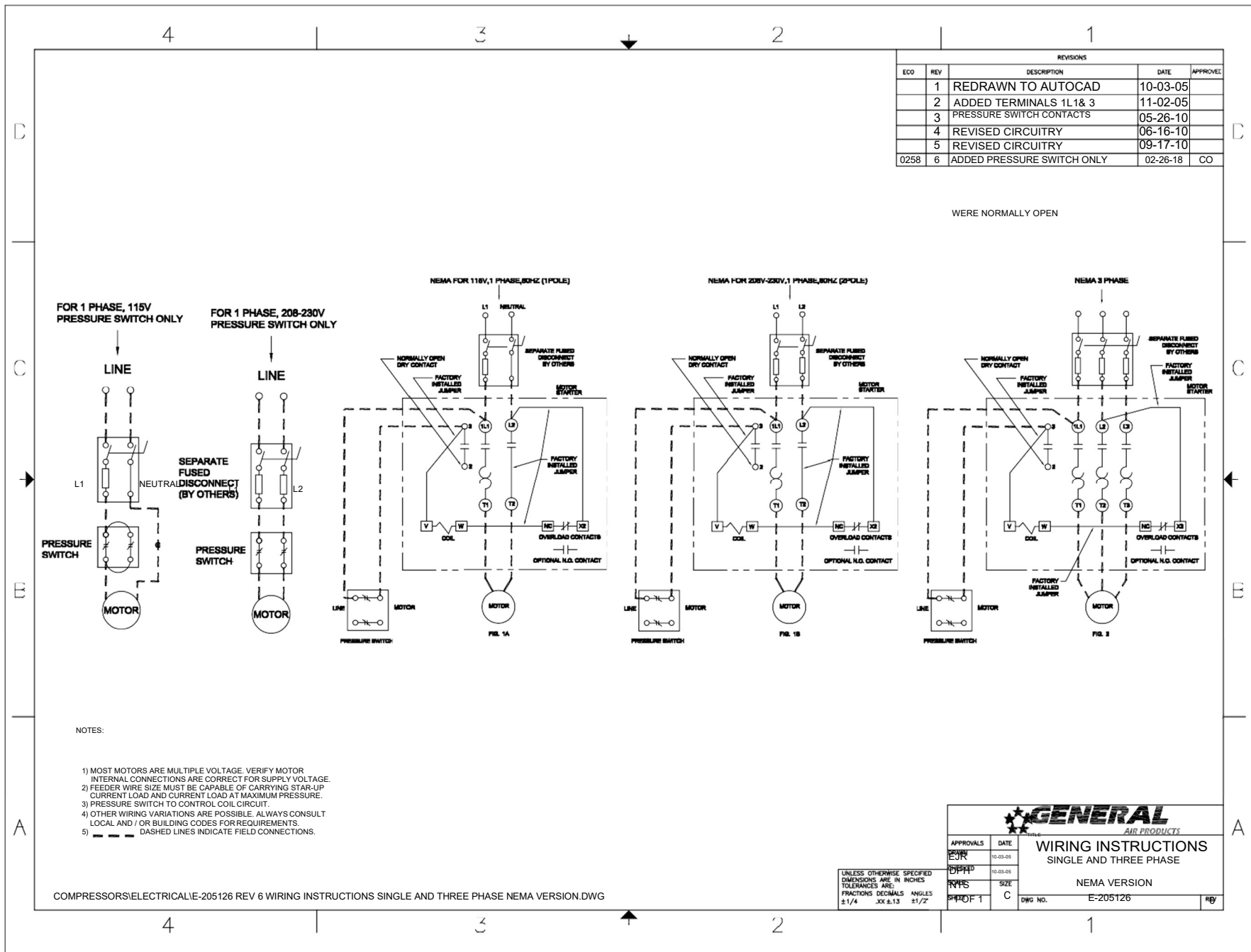

## **Section 8 - Maintenance Instructions**



Disconnect, tag and lock out power source then release all pressure from the system before attempting to install, service, relocate or perform any service.



Maintenance instructions for General Air Products lubricated air compressors:

The following instructions are based on normal operation. If the compressor is in an excessively dusty area, increase frequency of maintenance checks.

### **Quarterly and as needed:**

- Check oil level and inspect oil for contamination (APC01Q) Fill or change as needed
- Drain condensate from air receiver and traps and/or test automatic drains for functionality
- Check for unusual noise or vibration
- Clean air filters (only with non-petroleum products)
- Clean all external parts of the compressor and motor, inspect for physical damage
- Electrical power wiring to the compressor is intact and free of physical damage
- Piping from compressor to the fire protection system is secure, tight and free of physical damage
- Isolate compressor from system and inspect for leaks
- Manually test safety relief valve
- Check pulley set screws for tightness
- Check belt tension and wear
- Tighten all fittings, nuts and screws as needed

### **Annually and as needed:**

All quarterly checks plus the following:

- Change compressor oil (APC01Q) and make sure oil sight glass is clean
- Change air filter



The maintenance instructions below are per NFPA 25 Code Requirements:

### **13.10.2 - Inspection**

Air Compressors dedicated to water-based fire protection systems shall be inspected monthly to verify the following:

1. Air Compressor is free of physical damage.
2. Power wiring to the air compressor is intact and free of physical damage.
3. Piping from the air compressor to the fire protection system is intact and free of physical damage.
4. The means of anchoring the air compressor to the structure or to the system piping is secure, tight, and free of physical damage.
5. Air compressors requiring oil have the required amount of oil in the oil reservoir.

### **13.10.3 - Testing**

Air Compressors dedicated to water-based fire protection systems shall be tested annually to verify the following:

1. Air compressor operates as intended on the proper drop of air pressure in the fire protection system.
2. Air compressor restores normal air pressure in the fire protection system in the required time frame.
3. Air compressor does not overheat while running.

### **13.10.4 – Maintenance**

Air Compressors dedicated to water-based fire protection systems shall be maintained in accordance with the manufacturer's instructions (see above instructions).

1. Compressors requiring oil shall have the oil replaced on an annual basis unless the manufacturer's instructions require more frequent replacement.

**If there are any questions regarding installation, operation, or maintenance of this compressor, please call 800-345-8207**

# Section 9 - Troubleshooting Guide

Symptom	Possible Cause(s)	Corrective Action
Motor hums and runs slowly or not at all.	<ol style="list-style-type: none"> <li>1. Low or no voltage</li> <li>2. Shortened or open motor winding</li> <li>3. Defective check or unloader valve</li> <li>4. Defective pressure switch - contacts will not close</li> </ol>	<ol style="list-style-type: none"> <li>1. Check voltage during start. Voltage must be within +/- 10% of nominal voltage to start motor. Increase wire size if necessary to lower voltage drop.</li> <li>2. Replace motor</li> <li>3. Replace check valve or unloader valve</li> <li>4. Repair or replace pressure switch</li> </ol>
Reset mechanism cuts out or fuses blow repeatedly	<ol style="list-style-type: none"> <li>1. Insufficient voltage to motor</li> <li>2. Pressure switch set too high</li> <li>3. Wrong fuse size</li> <li>4. Piping too restrictive</li> <li>5. Defective motor</li> </ol>	<ol style="list-style-type: none"> <li>1. Check voltage during start. Voltage must be within +/- 10% of nominal voltage to start motor. Increase wire size if necessary to lower voltage drop.</li> <li>2. Consult factory, adjust or replace</li> <li>3. Be sure fuses, heaters and/or overloads are properly rated or set</li> <li>4. Add receiver vessel or increase pipe volume after compressor</li> <li>5. Replace motor</li> </ol>
Unit short cycles repeatedly	<ol style="list-style-type: none"> <li>1. Piping too restrictive</li> <li>2. Air leaks</li> </ol>	<ol style="list-style-type: none"> <li>1. Add receiver vessel or increase pipe volume after compressor</li> <li>2. Repair leaks</li> </ol>
Compressor overheating	<ol style="list-style-type: none"> <li>1. Dirty intake filter</li> <li>2. Wrong motor rotation</li> <li>3. Air flow to fan on flywheel blocked</li> </ol>	<ol style="list-style-type: none"> <li>1. Clean intake filter</li> <li>2. Correct rotation</li> <li>3. Clean air flow to fan or relocate unit</li> </ol>
Excessive noise in operation	<ol style="list-style-type: none"> <li>1. Loose pulley, flywheel, belt guard</li> <li>2. Lack of oil in crankcase</li> <li>3. Compressor mounting loose</li> </ol>	<ol style="list-style-type: none"> <li>1. Tighten</li> <li>2. Check for damage to bearings, replenish oil</li> <li>3. Shim and tighten</li> </ol>
Milky oil in reservoir	<ol style="list-style-type: none"> <li>1. Water flow from system into compressor</li> <li>2. Water condensing in crankcase due to high humidity</li> </ol>	<ol style="list-style-type: none"> <li>1. Inspect system check valve. repair or replace as necessary.</li> <li>2. Pipe air intake to less humid area. Run pump continuously for one hour and recheck</li> </ol>
System pressure builds slowly	<ol style="list-style-type: none"> <li>1. Compressor sized incorrectly</li> <li>2. Leaks or restrictions in piping</li> <li>3. Dirty intake filter</li> <li>4. Blown head gasket</li> </ol>	<ol style="list-style-type: none"> <li>1. Check system size and compressor sizing</li> <li>2. Correct leaks and remove restrictions</li> <li>3. Clean intake filter</li> <li>4. Replace head gasket</li> </ol>

# **Section 10 - Warranty Policy**

---

## **GENERAL PROVISIONS & LIMITATIONS**

General Air Products, Inc. (the "Company") warrants to each original purchaser ("Purchaser") of its new products from the Company or its Authorized Distributor that such products are, at the time of delivery to the Purchaser, made with good materials and workmanship. No warranty is made with respect to:

1. Any product, which has been repaired or altered in such a way, in the Companies judgment, as to affect the product adversely.
2. Any product, which has, in the Companies judgment been subjected to negligence, accident, improper storage, improper installation or application.
3. Any product, which has not been operated or maintained in accordance with the recommendations of the Company.
4. Components or accessories manufactured, warranted and serviced by others.
5. Any reconditioned or prior owned product.

Claims for items described in 4. above should be submitted directly to the manufacturer.

## **WARRANTY PERIOD**

The Company's obligation under this Warranty is limited to repair or, at its option, replacing during normal business hours at the designated facility of the Company, any part that in its judgment proved not to be as warranted within the applicable Warranty Period as follows.

## **COMPONENTS**

All non-consumable components are warranted for 12 months from the date of purchase. Consumables are not covered under warranty. The unit must have been installed by either a factory authorized distributor or agent in accordance with the factory recommendations taking into account all other local site conditions not originally noted to the factory. The unit must be operated and maintained in accordance with the Factory recommendations and original design conditions. Failure to provide such proof of the above may void warranty.

## **LABOR TRANSPORTATION & INSPECTION**

The Company will repair or replace any product or part thereof which in the Companies judgment is proved to be not as warranted. Labor costs are not covered under warranty.

All costs of transportation of product, labor or parts claimed not to be as warranted and, of repaired or replaced parts to or from factory shall be borne by purchaser. The Company may require the return of any part claimed not to be as warranted to one of its facilities as designated by the Company, transportation prepaid by Purchaser, to establish a claim under this warranty.

Replacement parts provided under the terms of the warranty are warranted for the remainder of the Warranty Period of the product upon which installed to the same extent as if such parts were original components.

## **DISCLAIMER**

THE FOREGOING WARRANTY IS EXCLUSIVE AND IT IS EXPRESSLY AGREED THAT, EXCEPT AS TO TITLE, THE COMPANY MAKES NO OTHER WARRANTIES, EXPRESSED OR IMPLIED OR STATUTORY, INCLUDING ANY IMPLIED WARRANTY OR MERCHANTABILITY.

THE REMEDY PROVIDED UNDER THIS WARRANTY SHALL BE THE SOLE, EXCLUSIVE AND ONLY REMEDY AVAILABLE TO THE PURCHASER AND IN NO CASE SHALL THE COMPANY BE SUBJECT TO ANY OTHER OBLIGATIONS OR LIABILITIES. UNDER NO CIRCUMSTANCES SHALL THE COMPANY BE LIABLE FOR SPECIAL, INDIRECT, INCIDENTAL OR CONSEQUENTIAL DAMAGES, EXPENSES, LOSSES OR DELAYS HOWSOEVER CAUSED.

No statement, representation, agreement, or understanding, oral or written, made by any agent, distributor, representative or employee of the Company which is not contained in this Warranty will be binding upon the company unless made in writing and executed by an officer of the Company.

This warranty shall not be effective as to any claim which is not presented within 30 days after the date upon which the product is claimed not to have been as warranted. Any action for breach of this warranty must be commenced within one year after the date upon which the cause of action occurred.

Any adjustment made pursuant to this warranty shall not be construed as an admission by the Company that any product was not as warranted.

## **PROMPT DISPOSITION & RETURNS POLICY**

The Company will make a good faith effort for prompt correction or other adjustment with respect to any product, which proves to be defective within the warranty period. Before returning any product, write or call the distributor, agent or authorized company from which the product was purchased, describing defect and giving date and number of original invoice, a well as proof of Factory supplied consumables and proof of scheduled maintenance. No products will be accepted for return without the Company issuing a "Returned Goods Authorization" (RGA) to the Purchaser and unless accompanied by a properly authorized RGA request form initiated by the Purchaser. Return freight must be prepaid and each returned product must have the RGA number clearly marked on the product. Title and risk of loss pass to buyer upon delivery to the common carrier.

## **PRODUCT SUITABILITY**

Many States, Localities and Countries have codes and regulations governing sales, construction, installation, and/or use of products for certain purposes, which may vary from those in neighboring areas. While General Air Products, Inc. attempts to assure that its products comply with such codes, it cannot guarantee compliance, and cannot be responsible for how the product is installed or used? Before purchase and use of a product, please review the product application, and national and local codes and regulations, and be sure that the product, installation, and use will comply with them.

**General Air Products, Inc.**  
118 Summit Drive  
Exton, PA 19341  
P: 610-524-8950  
F: 610-524-8965

REV:4/22/11