

ZONE	REV	DESCRIPTION	DATE	APPROVED
	0	RELEASED ON EGN #0121	8-25-14	RM
	1	RELEASED ON EGN #0144	1-21-15	RCL

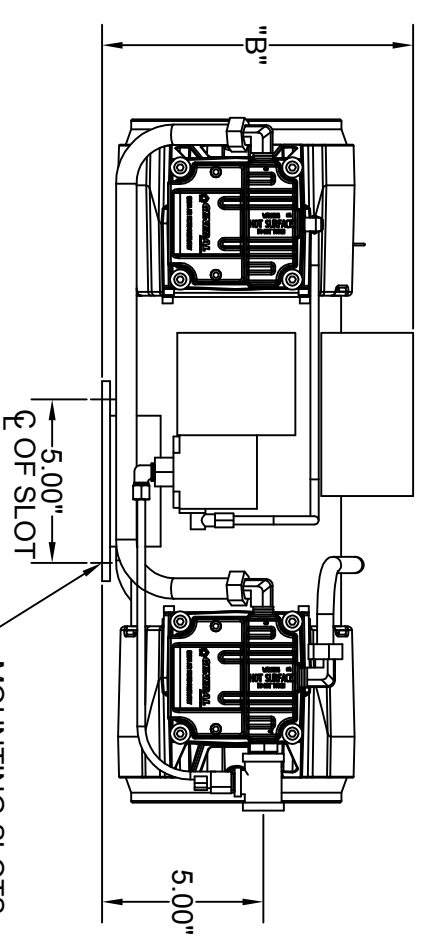

MOUNTING SLOTS
40" WIDE X 1.87" LONG
(4 PLACES)

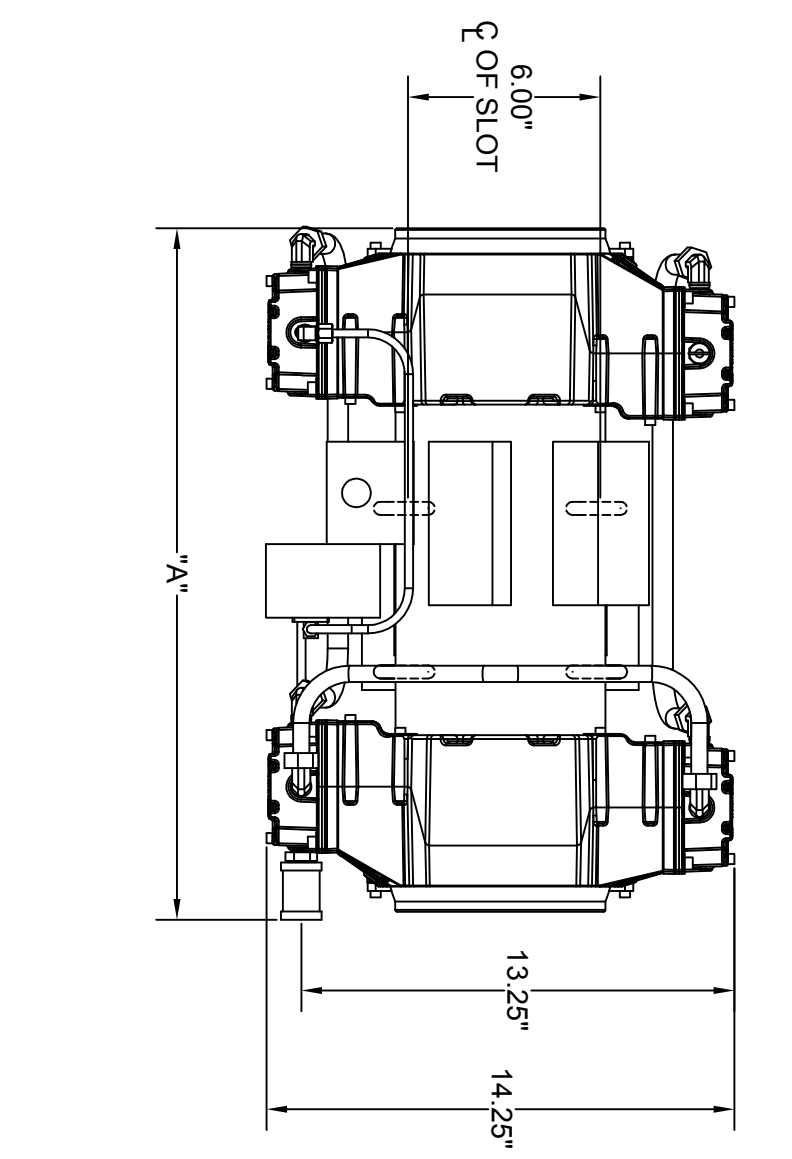
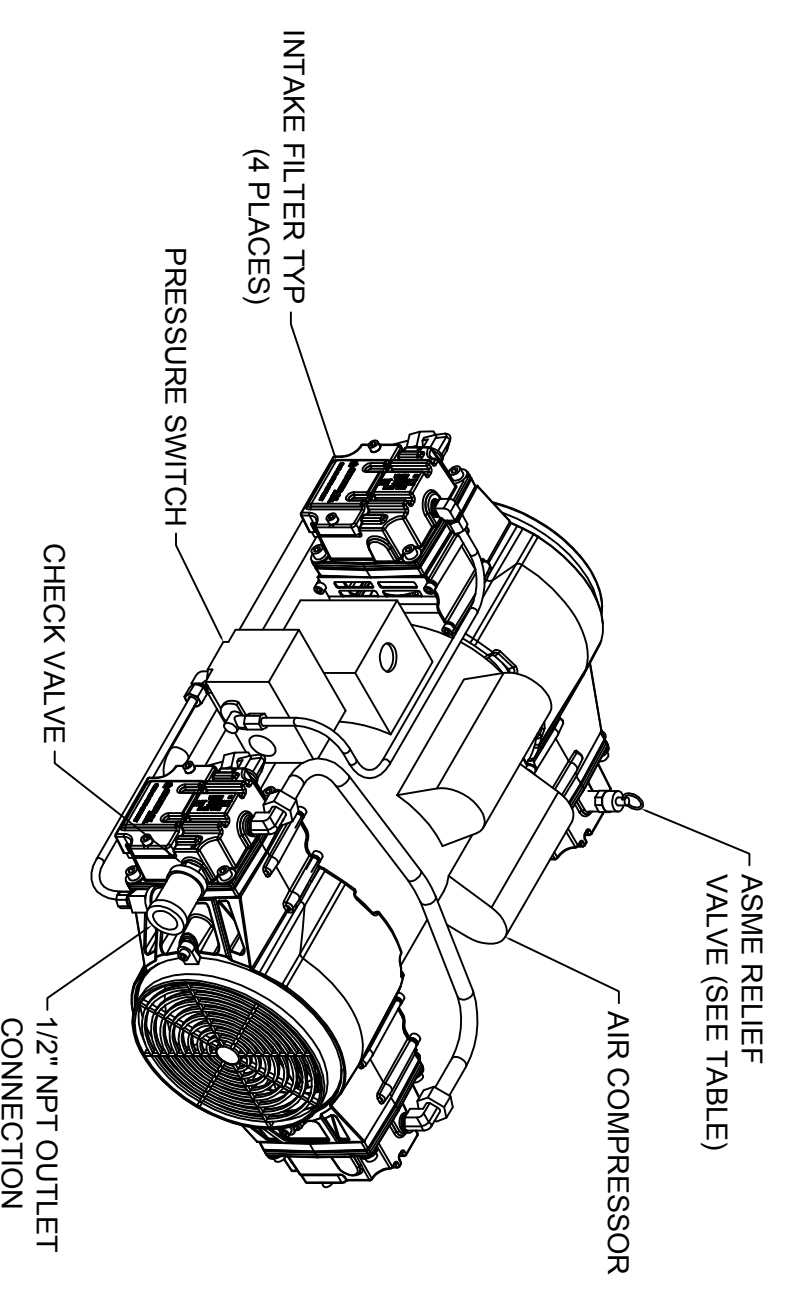

MODEL	MOTOR	VOLTAGE	PRESSURE SWITCH SETTINGS		RELIEF VALVE	DIM "A"	DIM "B"	NET WEIGHT	REBUILD KIT *
			ON	OFF					
OL915150AC	1-1/2 HP	115/208-230V/1PH/60HZ	27 TO 30 PSIG	40 TO 44 PSIG	75 PSIG	22.00"	9.50"	60 LBS.	OLC-RK
OL2870150AC-50		220-240V/1PH/50HZ	27 TO 30 PSIG	40 TO 44 PSIG	75 PSIG	23.75"	9.00"		
OL2870150BC-50		190/220/380-415V/3PH/50	27 TO 30 PSIG	40 TO 44 PSIG	75 PSIG	23.75"	9.00"		
OL915150BC		208-230/460V/3PH/60HZ	27 TO 30 PSIG	40 TO 44 PSIG	75 PSIG	22.00"	9.00"		
OL915150BC-HP	2 HP	208-230/460V/3PH/60HZ	80 PSIG	100 PSIG	125 PSIG	22.00"	9.00"	70 LBS.	
OL915200AC-HP		208-230V/1PH/60HZ	80 PSIG	100 PSIG	125 PSIG	23.50"	10.75"		
OL1225200AC		208-230V/1PH/60HZ	27 TO 30 PSIG	40 TO 44 PSIG	75 PSIG	23.50"	10.75"		
OL1100200AC-HP		208-230V/1PH/60HZ	80 PSIG	100 PSIG	125 PSIG	23.50"	10.75"		
OL1225200BC		208-230/460V/3PH/60HZ	27 TO 30 PSIG	40 TO 44 PSIG	75 PSIG	23.50"	10.75"		
OL1100200BC-HP		208-230/460V/3PH/60HZ	80 PSIG	100 PSIG	125 PSIG	23.50"	10.75"		
OL3840200AC-50		220-240V/1PH/50HZ	27 TO 30 PSIG	40 TO 44 PSIG	75 PSIG	23.50"	10.75"		
OL3840200BC-50		190/220/380-415V/3PH/50	27 TO 30 PSIG	40 TO 44 PSIG	75 PSIG	23.50"	10.75"		

* REBUILD KIT(OLC-RK) CONSISTS OF REPLACEMENT CYLINDER CUP AND INTAKE FILTER.

- NOTES:
1. COMPRESSOR APPEARANCE MAY VARY.
 2. DIMENSIONS ARE SUBJECT TO CHANGE WITHOUT NOTICE.
 3. ALL PIPING MUST BE INDEPENDENTLY SUPPORTED TO AVOID ANY UNDO STRESS ON COMPRESSOR HEAD.

UNLESS OTHERWISE SPECIFIED DIMENSIONS ARE IN INCHES TOLERANCES ARE:

FRACTIONS DECIMALS ANGLES
±1/2 .XX ±.100° ±1/2°

THIS DRAWING AND ALL OF ITS CONTENTS ARE THE SOLE PROPERTY OF GENERAL AIR PRODUCTS, INC. DETAILS MAY CHANGE WITHOUT NOTICE. THE CONTENTS OF THIS DRAWING MAY NOT BE REPRODUCED OR INCORPORATED IN ANY EQUIPMENT, DRAWING, OR WHOLE OR PART OF ANY PRODUCT, WITHOUT WRITTEN CONSENT OF GENERAL AIR PRODUCTS, INCORPORATED.

APPROVALS		DATE	TITLE
DRAWN		08/25/14	GENERAL AIR PRODUCTS GENERAL ARRANGEMENT 4 CYLINDER OIL LESS FIRE PROTECTION COMPRESSOR, RISER MOUNT
CHECKED		08/25/14	
SCALE		NONE	
SHEET 1/1		DWG. NO.	REV
		G-214212	1