

ZONE	REV	DESCRIPTION	DATE	APPROVED
	0	RELEASED ON ECN#0121	8/27/14	RM
	1	RELEASED ON ECN#0144	1/21/15	RCL

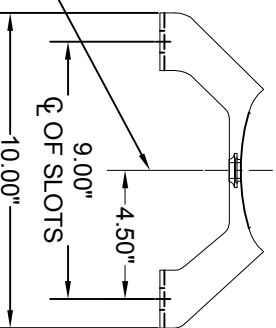
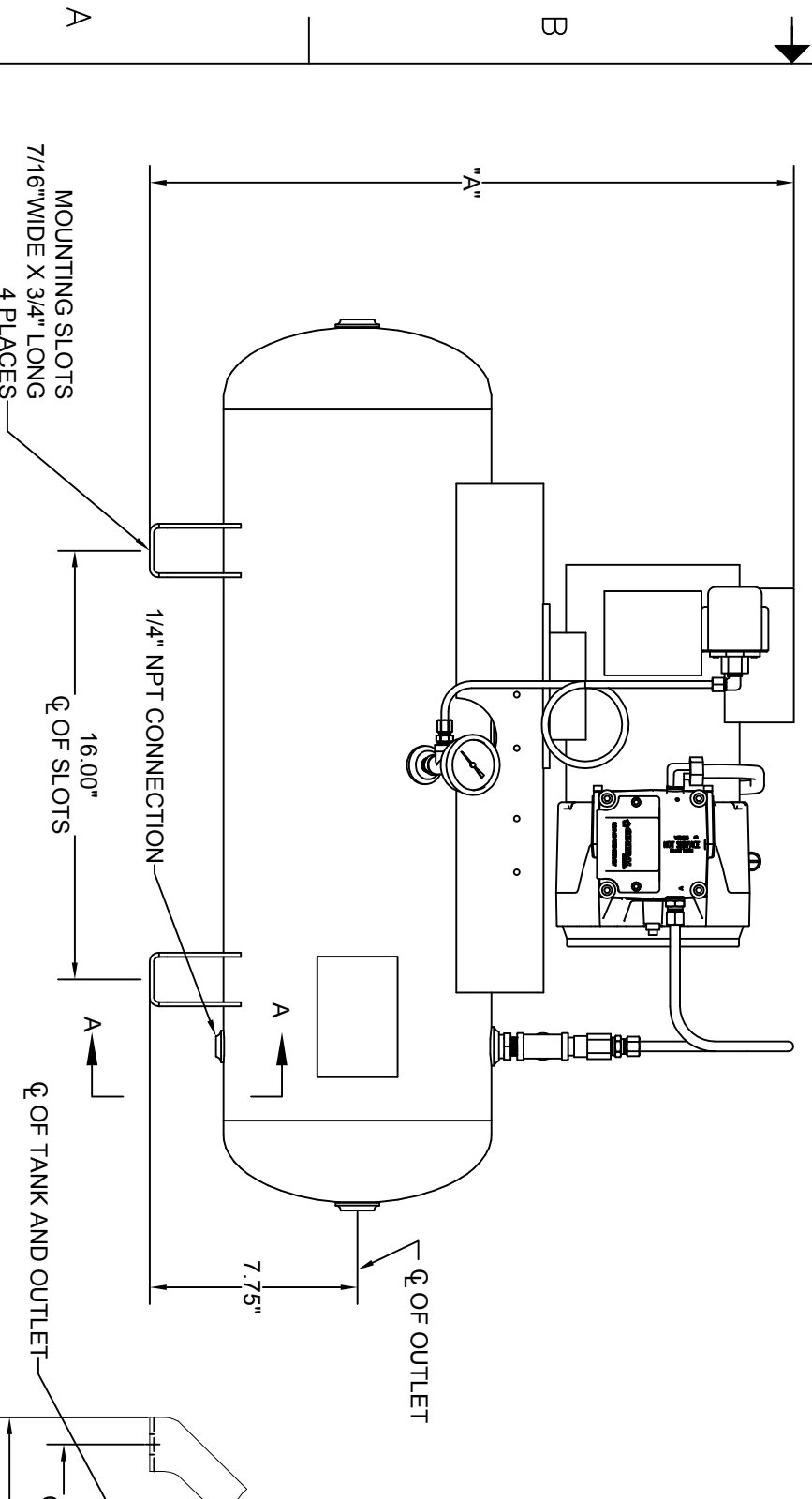
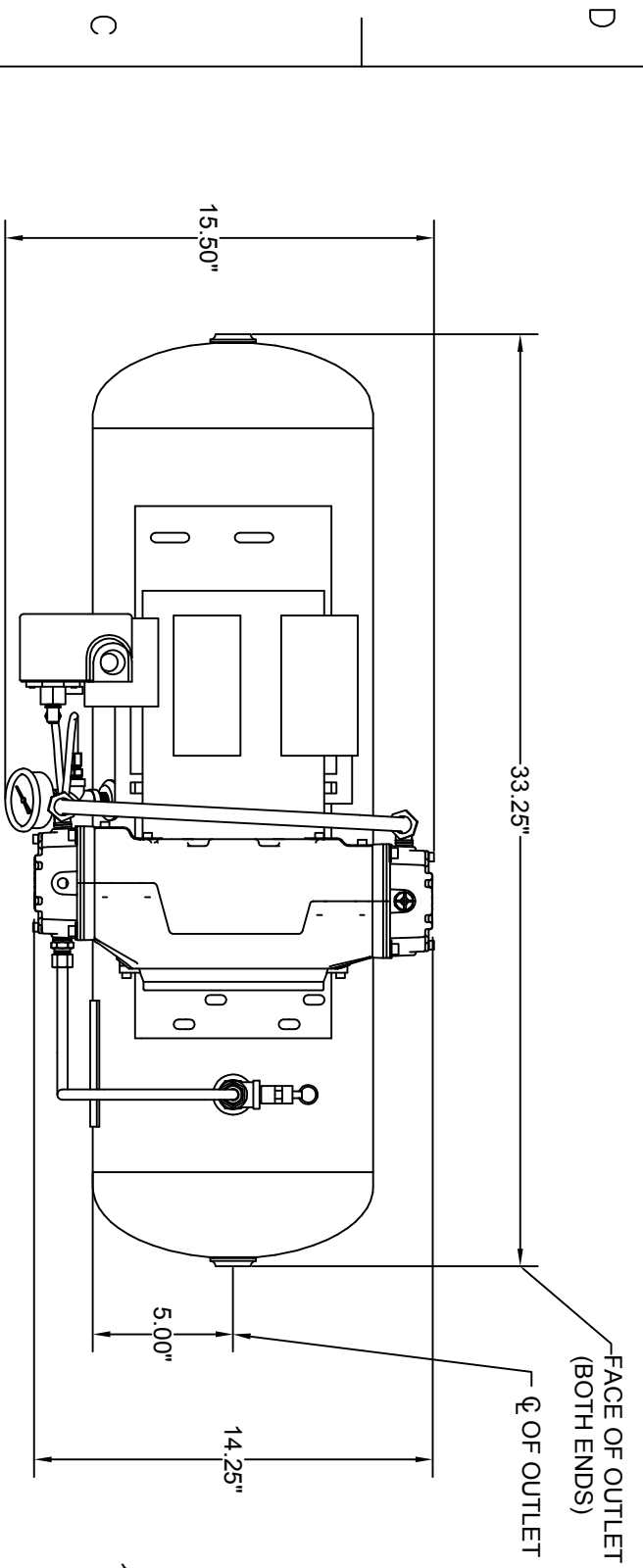
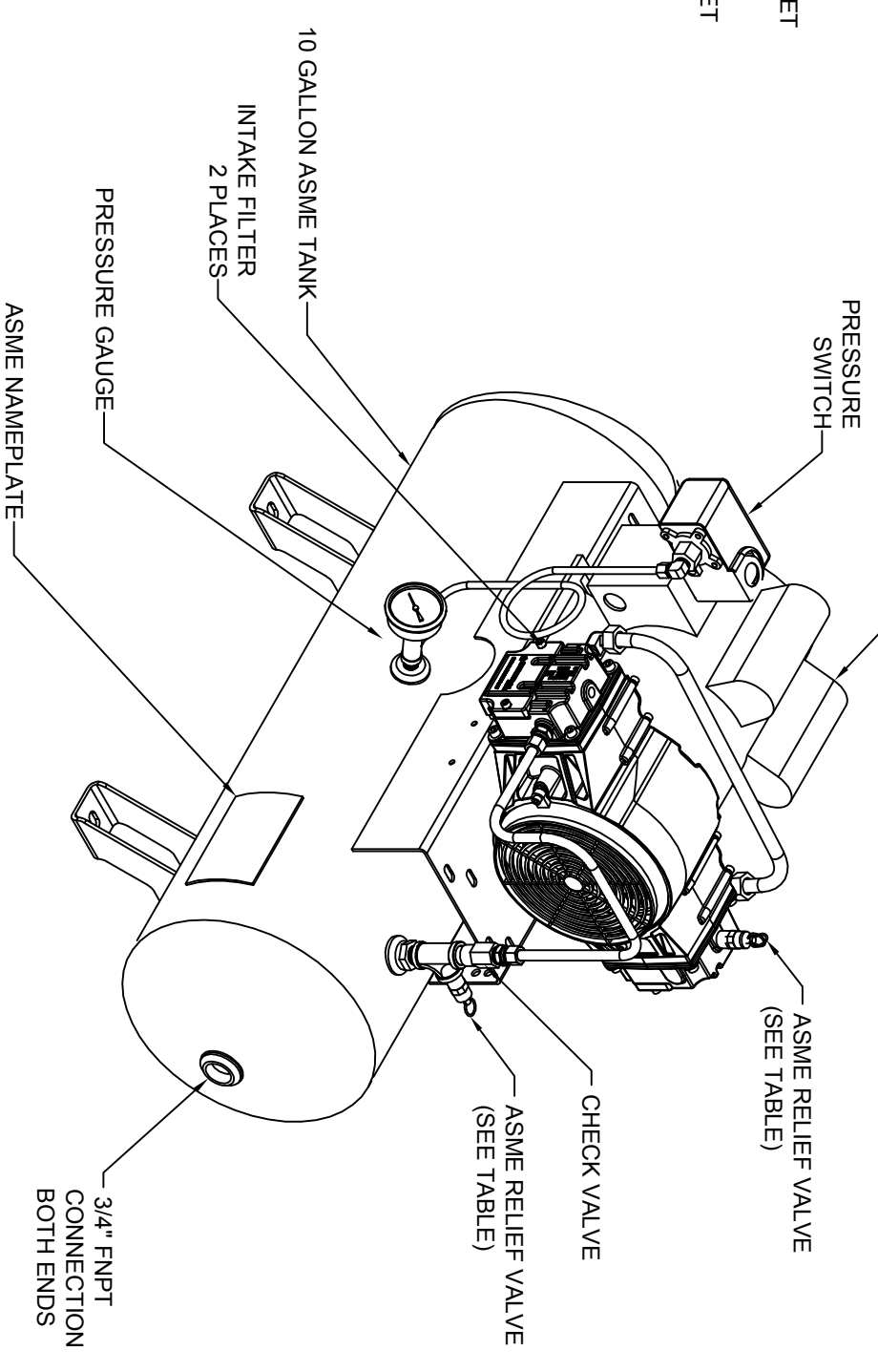

MODEL	MOTOR	VOLTAGE	PRESSURE SWITCH SETTINGS		RELIEF VALVE	DIM "A"	NET WEIGHT	REBUILD * KIT #
			ON	OFF				
OL36550ACT	1/2 HP	115/208-230V/1PH/60HZ	27 TO 30 PSIG	40 TO 44 PSIG	75 PSIG	23.50"		
OL36550ACT-HP		115/208-230V/1PH/60HZ	80 PSIG	100 PSIG	125 PSIG	23.50"		
OL36550BCT		208-230/460V/3PH/60HZ	27 TO 30 PSIG	40 TO 44 PSIG	75 PSIG	24.00"	82 lbs.	OLC-RK
OL36575BCT-HP	3/4 HP	208-230/460V/3PH/60HZ	80 PSIG	100 PSIG	125 PSIG	24.00"		
OL43075ACT		115/208-230V/1PH/60HZ	27 TO 30 PSIG	40 TO 44 PSIG	75 PSIG	23.50"		
OL43075BCT		208-230/460V/3PH/60HZ	27 TO 30 PSIG	40 TO 44 PSIG	75 PSIG	24.00"	92 lbs.	
OL36575ACT-HP		115/208-230V/1PH/60HZ	80 PSIG	100 PSIG	125 PSIG	24.00"		
OL430100ACT-HP	1HP	115/208-230V/1PH/60HZ	80 PSIG	100 PSIG	125 PSIG	23.50"		
OL430100BCT-HP		208-230/460V/3PH/60HZ	80 PSIG	100 PSIG	125 PSIG	23.50"		
OL615100ACT		115/208-230V/1PH/60HZ	27 TO 30 PSIG	40 TO 44 PSIG	75 PSIG	23.50"	92 lbs.	
OL615100BCT		208-230/460V/3PH/60HZ	27 TO 30 PSIG	40 TO 44 PSIG	75 PSIG	24.00"		
OL550100ACT-HP		115/208-230V/1PH/60HZ	80 PSIG	100 PSIG	125 PSIG	23.50"		
OL550100BCT-HP		208-230/460V/3PH/60HZ	80 PSIG	100 PSIG	125 PSIG	23.50"		

* REBUILD KIT (OLC-RK) CONSISTS OF REPLACEMENT CYLINDER CUP AND INTAKE FILTER.

- NOTES:
1. COMPRESSOR APPEARANCE MAY VARY.
2. DIMENSIONS ARE SUBJECT TO CHANGE WITHOUT NOTICE.
3. ALL PIPING MUST BE INDEPENDENTLY SUPPORTED TO AVOID ANY UNDO STRESS ON COMPRESSOR HEAD.

UNLESS OTHERWISE SPECIFIED DIMENSIONS ARE IN INCHES TOLERANCES ARE:
FRACTIONS DECIMALS ANGLES
±1/2 .XX ±1.00° ±1/2°

THIS DRAWING AND ALL OF ITS CONTENTS ARE THE SOLE PROPERTY OF GENERAL AIR PRODUCTS, INC. DETAILS MAY CHANGE WITHOUT NOTICE. THE CONTENTS OF THIS DRAWING MAY NOT BE REPRODUCED OR INCORPORATED IN WHOLE OR IN PART IN ANY EQUIPMENT, PRODUCT, OR SERVICE WITHOUT THE WRITTEN CONSENT OF GENERAL AIR PRODUCTS, INC. (INCORPORATED).

		DATE	08/27/14
		APPROVALS	
TITLE		DATE	08/27/14
GENERAL ARRANGEMENT		CHECKED	RM
2 CYLINDER OIL LESS FIRE PROTECTION		SCALE	1/1
COMPRESSOR, TANK MOUNT		SIZE	
DWG. NO.		SHEET	1/1
G-214214		REV	1

Engineering\Project C\Cyclone\Cyclone\New Full Assemblies\TANK MOUNT\DRAWINGS\G-214214 REV 1 GENERAL ARRANGEMENT 2 CYLINDER TANK MOUNT.DWG