

Open Basic Residential Fire Protection Pump System

General Air Products' Residential Fire Protection Pump System (RFP System) is the benchmark of quality for meeting 2010 NFPA 13D application requirements.

Our basic RFP Systems deliver a wide variety of features and benefits that work together to meet the need of your application simply, efficiently and reliably.

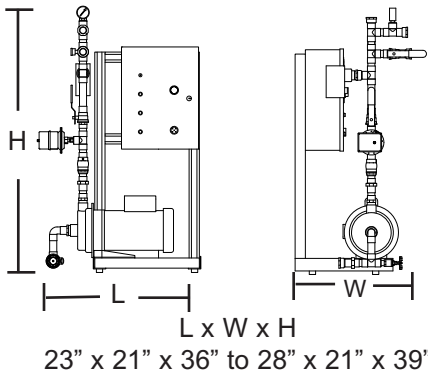

- True Stainless Steel Pump
- Non-Ferrous Piping System
- NEMA Rated Electrical Control Box
- Power "On" Indicator
- Pump Test Button
- Audible Alarm System
- Alarm Signal Contact
- Water Delivery Pressure Gauge
- DPDT Flow Switch
- Adjustable Pressure Switch
- Suction Line
- **See Brochure for Complete Feature List**

Model Number	AMP Draw*	Weight (lbs.)
OPS11-X	9.8	121
OPS13-X	9.8	112
OPS14-X	9.8	130
OPS15-X	9.8	130
OPS16-X	11.0	112
OPS17-X	12.8	116
OPS18-X	13.8	146
OPS19-X	13.8	145
OPS20-X	13.8	170
OPS21-X	19.5	180
OPS22-X	23.7	199
OPS23-X	23.7	204
OPS24-X	29.0	270
OPS25-X	29.0	270

NOTE: Use page 2 of this document to select the correct model number based on your systems' pressure and flow requirements.

***Standard RFP System Voltage is 230/1/60. For other voltage requirements, consult factory.**

All information subject to change without notice.