

4

3

2

1

REVISIONS				
ECO	REV	DESCRIPTION	DATE	APPROVED
0647	0	RELEASE OF DRAWING	05/20/22	DPH

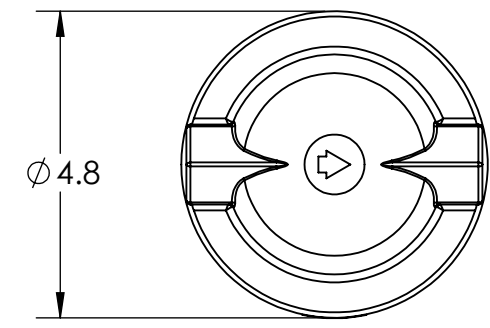

Ø 4.8

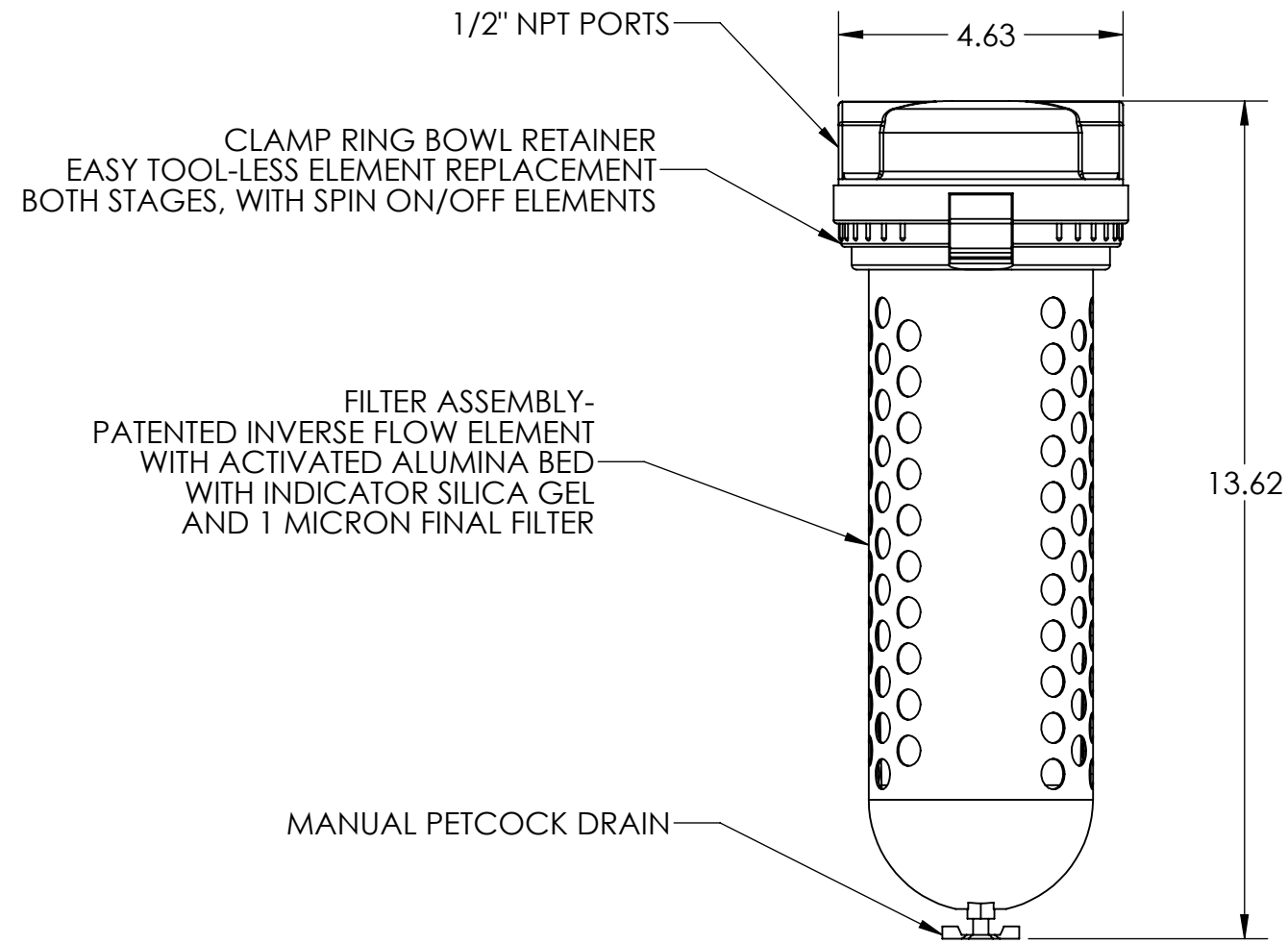

1/2" NPT PORTS

4.63

CLAMP RING BOWL RETAINER
EASY TOOL-LESS ELEMENT REPLACEMENT
BOTH STAGES, WITH SPIN ON/OFF ELEMENTS

13.62

FILTER ASSEMBLY-
PATENTED INVERSE FLOW ELEMENT
WITH ACTIVATED ALUMINA BED
WITH INDICATOR SILICA GEL
AND 1 MICRON FINAL FILTER

MANUAL PETCOCK DRAIN

NOTES -

1. FILTER ASSEMBLY - RED EPOXY COATED WITH POLYCARBONATE BOWL WITH GUARD.
2. CAPACITY - 25 SCFM @ 100 PSI.
3. ACTIVATED ALUMINA BED WITH SILICA GEL INDICATOR AND 1.0 MICRON FINAL FILTER.
4. WEIGHT - APPROX. 6.8 LBS.
5. MAX. TEMPERATURE = 125°F AND MAX. PRESSURE = 150 PSI.
6. PRESSURE DIFFERENTIAL < 2.0 PSI AT RATED FLOW.
7. MAINTENANCE CLEARANCE OF 9" REQUIRED FOR CARTRIDGE REPLACEMENT.
8. REPLACEMENT CARTRIDGE - PART# AD3500-ELM.



APPROVALS	DATE	TITLE:
DRAWN DPH	5/20/2022	MANUAL DESICCANT DRYER MODEL AD3500
CHECKED WLW	5/20/2022	
SCALE NONE	SIZE	DWG. NO.
SHEET 1 OF 1	B	G-222177
		REV 0

UNLESS OTHERWISE SPECIFIED,
DIMENSIONS ARE IN INCHES.
TOLERANCES ARE:

FRACTIONS	DECIMALS	ANGLES
±x	.xx ±.25	±1°

THIS DRAWING AND ALL OF ITS CONTENTS ARE THE SOLE PROPERTY OF GENERAL AIR PRODUCTS, INC. DETAILS MAY CHANGE WITHOUT NOTICE. THE CONTENTS OF THIS DRAWING MAY NOT BE REPRODUCED OR INCORPORATED IN WHOLE OR IN PART IN ANY EQUIPMENT, NOR THE MANUFACTURE OF ANY PARTS, WITHOUT WRITTEN CONSENT OF GENERAL AIR PRODUCTS, INCORPORATED.

4

3

2

1