

**OL Advance  
Series**

**Oil-Less, Riser Mount Air Compressors  
for Dry Pipe & Pre-Action Sprinkler Systems**

Introducing the most advanced Fire Protection Air Compressors ever built! The OL Advance Series Riser Mount Air Compressors Feature an all-new, UL 508 Listed, General Air Products Digital Pressure Switch. The OL Advance Series Air Compressors are UL 1450-VDUR Listed and specifically designed to fill dry pipe and pre-action fire sprinkler systems to supervisory pressure within 30 minutes per NFPA 13.

- UL 1450-VDUR Listed
- Oil-Less Piston Compressor
- UL Listed, Digital Pressure Switch
- Fully Automatic, Direct Drive
- Includes Riser Mounting Bracket, 30" Stainless Steel Flex Hose & Union
- ASME Pressure Safety Valve
- Bubble Tight Air Check Valve
- Pre-Wired & Pre-Tested
- Lifetime Technical Support



**New Digital Pressure Switch:** The ONLY UL Listed Digital Pressure Switch in the Fire Protection industry designed and built by the compressor manufacturer themselves. Displays Pressure Readings, Run Hours, Amps, Cycles, and is extremely easy to adjust pressure settings in the field.

System Capacity (gal)*		Model Number	Average CFM**	Motor HP	Voltage (volts)	Amperage (amps)		Recommended Wire Size (gage)			Unit Weight (lbs)
@ 40 PSI	@ 20 PSI					FLA	Start Up	25' Run	50' Run	100' Run	
120	320	OLRV12016AC	1.46	1/6	115	3.5	25	12	12	12	29
					208-230	1.9	13.3	12	12	12	
250	550	OLRV25033AC	3.03	1/3	115	4.3	30.1	12	12	10	33
					208-230	2.3	16.1	12	12	12	
400	860	OLRV40050AC	4.85	1/2	115	9.4	65.8	12	10	6	45
					208-230	4.9	34.3	12	12	12	
500	995	OLRV50075AC+	6.06	3/4	115	9.4	65.8	12	10	6	45
					208-230	4.9	34.3	12	12	12	
600	1250	OLRV600100AC+	7.28	1	115	9.4	65.8	12	10	6	45
					208-230	4.9	34.3	12	12	12	

\* System Capacity based on 30min fill at 40 PSIG and 70°F system temperature.

\*\* CFM is based on the average free air delivery as the system fills from 0 to 40 PSIG.

+ Compressor has a capacity above 5.5 CFM at 10 PSIG. Air Maintenance Device required per NFPA 13.

**Note:** All information is subject to change without notice. Consult factory for most up-to-date product details.

 WARNING: Cancer and Reproductive Harm - [www.p65warnings.ca.gov](http://www.p65warnings.ca.gov)

**Fire Protection Air Compressor Accessories**

**Air Maintenance Device - Part # AMD-1**



The AMD-1 regulates the volume of air being delivered to the sprinkler system by the air compressor.

**Per NFPA 13 - An Air Maintenance Device is required on every dry system unless the air compressor has a capacity less than 5.5 ft<sup>3</sup>/min at 10 PSI.**

**Motor Line Starter - Thermal Overload Protection**



SINGLE PHASE MOTOR LINE STARTERS				
	115V	208/230V	Size	Model
MAX HP	1/3 HP	1 HP	00	MG00A
	1 HP	2 HP	0	MGX0A
	2 HP	3 HP	1	MG01A
	3 HP	5 HP	1P	MG15A

When Ordering a Motor Starter you must specify HP, Voltage & Phase.

## OL Advance Series - Riser Mount Fire Protection Air Compressors

**Model: OLRV12016AC**

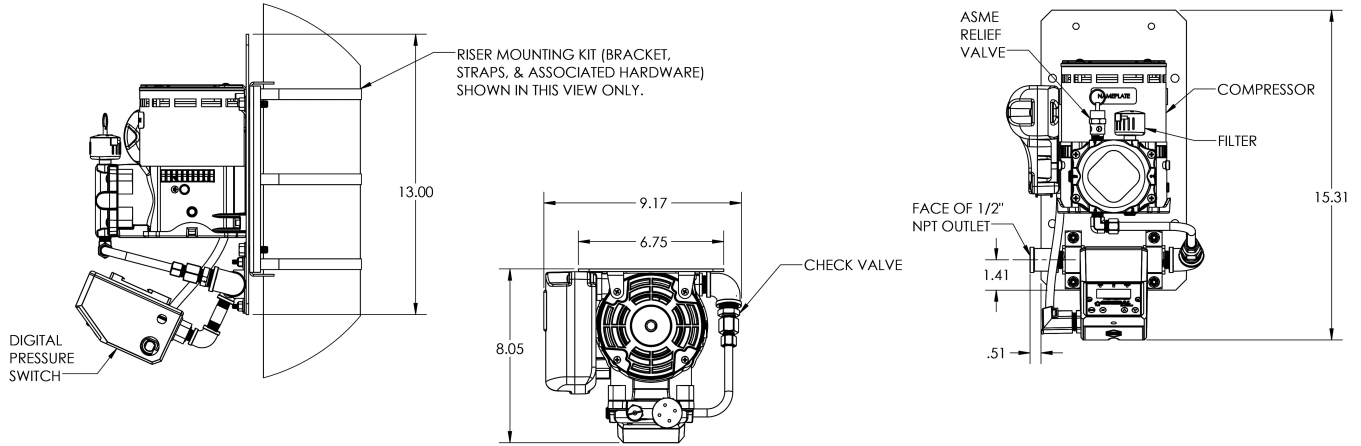

**Model: OLRV25033AC**

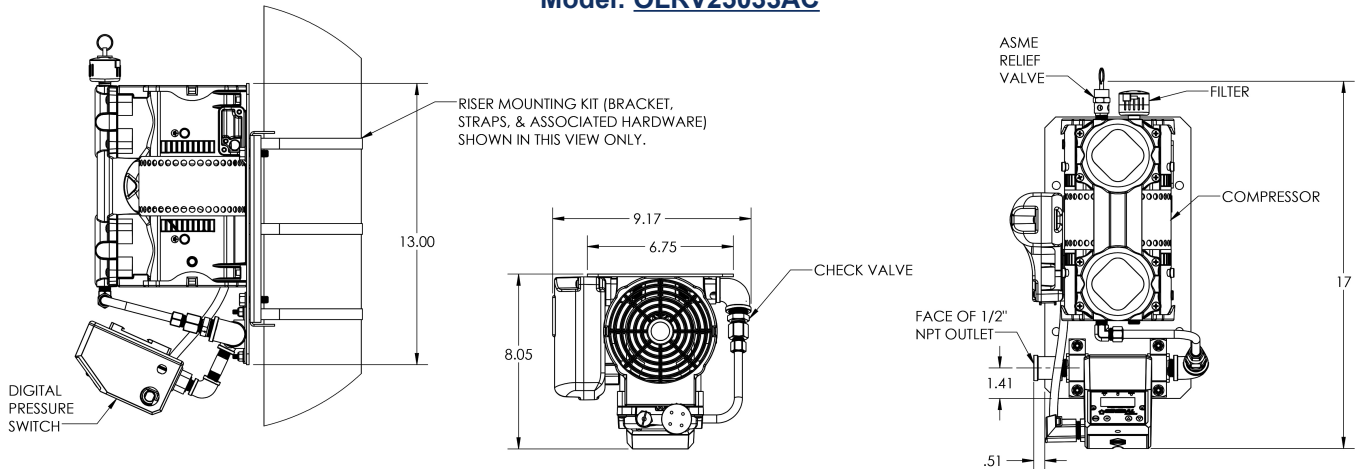

**Models: OLRV40050AC | OLRV50075AC | OLRV600100AC**

