

Oil-Less Riser Mount Fire Protection Air Compressors for Dry Pipe & Pre-Action Sprinkler Systems.

OL Plus Series

General Air Products newly improved OL Plus Series Oil Less Riser Mount Fire Protection Air Compressors are UL 1450-VDUR Listed and specifically designed to fill dry pipe and pre-action fire sprinkler systems to 40 PSI within 30 minutes per NFPA 13.



Includes Riser Mounting Bracket, 30" Stainless Steel Flex Hose & Union.



System Capacity (gal)* @40 PSI	Model Number	CFM @10 PSIG	Motor HP	Voltage (volts)	Amperage (amps)		Recommended Wire Size (gage)			Unit Weight (lbs)
					FLA	Start Up	25' Run	50' Run	100' Run	
120	OLR12016AC	1.46	1/6	115	3.8	27	12	12	12	29
				208-230	2.2	15	12	12	12	
250	OLR25033AC	3.03	1/3	115	4.3	30	12	12	10	33
				208-230	2.3	16	12	12	12	
400	OLR40050AC	4.85	1/2	115	9.4	66	12	10	6	45
				208-230	4.9	34	12	12	12	
500	OLR50075AC ⁺	6.06 ⁺	3/4	115	9.9	69	12	10	6	45
				208-230	5.1	36	12	12	12	
600	OLR600100AC ⁺	7.28 ⁺	1	115	11.3	79	12	10	6	45
				208-230	5.7	40	12	12	12	
915	OLR915150AC ⁺	11.10 ⁺	1 1/2	115	16.6	116	12	8	8	60
				208-230	8.3	58	10	8	6	
1225	OLR1225200AC ⁺	14.85 ⁺	2	208	11.3	79	10	8	6	70
				230	9.6	79	12	12	10	

Features and Benefits

- UL 1450-VDUR Listed
- Oil-Less Piston Compressor
- UL Listed, Pre-Set Pressure Switch
- Fully Automatic, Direct Drive
- ASME Pressure Safety Valve
- Bubble Tight Air Check Valve
- Pre-Wired & Pre-Tested
- Lifetime Technical Support
- Includes Riser Mounting Bracket, 30" Stainless Steel Flex Hose & Union

* System Capacity based on 30min fill-time at 70° F system temperature.

⁺ Compressor has a capacity above 5.5 CFM @ 10 PSIG. A listed Air Maintenance Device is required on systems supervised by this compressor per NFPA 13.

Note: All information is subject to change without notice. Consult factory for most up-to-date product details.

WARNING: Cancer and Reproductive Harm – www.p65warnings.ca.gov

OL Plus Series Riser Mount Fire Protection Air Compressors Accessories

VAPOR PIPE SHIELD



Vapor Pipe Shield is a Patented and UL Listed innovative solution for the prevention of corrosion in Dry-Pipe & Pre-Action Fire Sprinkler Systems.

AIR MAINTENANCE DEVICE



Part # AMD-1

The AMD-1 regulates the volume of air being delivered to the sprinkler system by the air compressor.

Per NFPA 13 - An Air Maintenance Device is required on every dry system unless the air compressor has a capacity less than 5.5 ft³/min at 10 PSI.

MOTOR LINE STARTER



Thermal Overload Protection

SINGLE PHASE MOTOR LINE STARTERS			
MAX HP	115V	208-230V	Size Model
1/3 HP	1 HP	00	MG00A
1 HP	2 HP	0	MG00A
2 HP	3 HP	1	MG01A
3 HP	5 HP	1P	MG15A

When Ordering a Motor Starter you must specify HP, Voltage & Phase.

OL Plus Series Riser Mount Fire Protection Air Compressors

MODEL: OLR12016AC

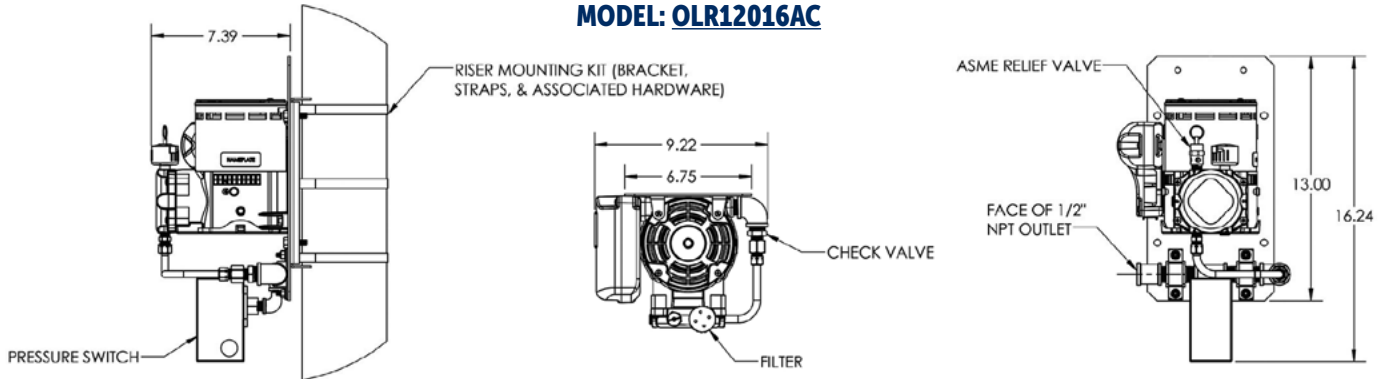

MODEL: OLR25033AC

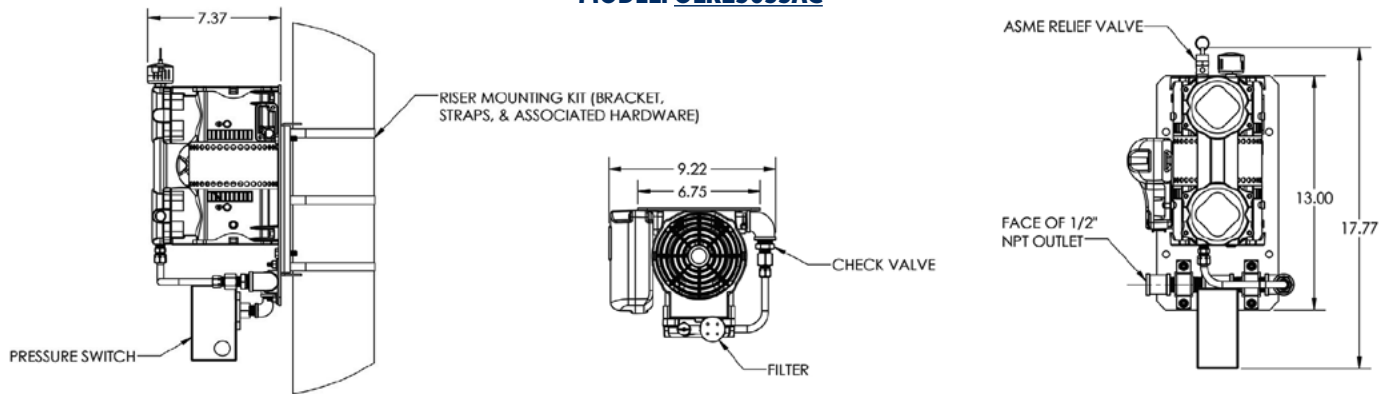

MODELS: OLR40050AC | OLR50075AC | OLR600100AC

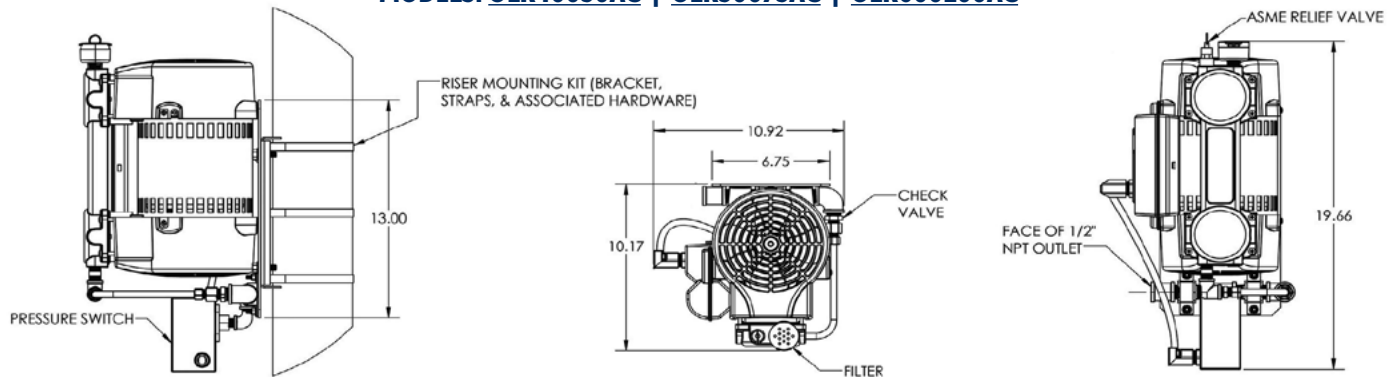

MODELS: OLR915150AC | OLR12252005AC

