

Oil-Less Tank Mounted Digital Fire Protection Air Compressors for Dry Pipe & Pre-Action Sprinkler Systems.

Our OL Advance Series Tank Mounted Digital Air Compressors Feature an all-new, UL-508 Listed, General Air Products Digital Pressure Switch. Our digital pressure switch makes it easy to adjust and maintain pressure from low, standard or high pressure, while cutting down on setup time. The Digital Pressure Switch also actuates an Automatic Drain Valve on tank mounted units.

PRE-SET PRESSURES FOR EASY INSTALLATION

Standard Pressure

45/60

High Pressure

80/100

Easily adjust to any custom setting with the push of a button. All tank mounted compressors require an Air Maintenance Device to regulate system pressure.

OL Advance Series



Includes Vibration Pads, 30" Stainless Steel Flex Hose & Union.

System Capacity @40 PSI (gal)*	Model Number	CFM @10 PSIG	Motor HP	Voltage (volts)	Amperage (amps)		Recommended Wire Size (gauge)			Tank Size	Unit Weight (lbs)
					FLA	Start Up	25' Run	50' Run	100' Run		
120	OLTV12016AC	1.46	1/6	115	3.8	27	12	12	12	10	83
				208-230	2.2	15	12	12	12		
250	OLTV25033AC	3.03	1/3	115	4.3	30	12	12	10	10	87
				208-230	2.3	16	12	12	12		
400	OLTV40050AC	4.85	1/2	115	9.4	66	12	10	6	10	68
				208-230	4.9	34	12	12	12		
500	OLTV50075AC	6.06	3/4	115	9.9	69	12	10	6	10	98
				208-230	5.1	36	12	12	12		
600	OLTV600100AC	7.28	1	115	11.3	79	12	10	6	10	98
				208-230	5.7	40	12	12	12		

Features and Benefits

- CULUS - VDUR Listed 1450-US - CSAC22.2No.68-Canada
- Oil-Less Piston Compressor
- UL Listed, Digital Pressure Switch
- Displays Pressure Readings
- Displays & Records Run Hours
- Displays Amperage
- Displays & Records Cycles
- Fully Automatic, Direct Drive
- ASME Pressure Safety Valve
- Bubble Tight Air Check Valve
- Pre-Wired & Pre-Tested
- Lifetime Technical Support
- Automatic Tank Drain Valve
- Annual Automated Maintenance Reminders

* System Capacity based on 30min fill-time at 70° F system temperature.

Note: A listed Air Maintenance Device must be installed in conjunction with all Tank Mounted air compressors.

Note: All information is subject to change without notice. Consult factory for most up-to-date product details.

⚠ WARNING: Cancer and Reproductive Harm - www.p65warnings.ca.gov

System Capacity (gal) by System Pressure

Model Number	@20 PSI	@30 PSI	@40 PSI	@50 PSI	@60 PSI	@70 PSI	@80 PSI	@90 PSI	@100 PSI
OLTV12016AC	265	170	120	95	75	65	55	45	40
OLTV25033AC	565	350	250	190	155	125	105	90	75
OLTV40050AC	930	595	400	325	255	215	180	155	135
OLTV50075AC	1030	655	500	360	290	240	200	170	145
OLTV600100AC	1250	790	600	435	350	285	240	210	180

The OL Advance Series Digital Fire Protection Air Compressors are UL 1450-VDUR Listed and specifically designed to fill dry pipe and pre-action fire sprinkler systems to supervisory pressure within 30 minutes per NFPA 13.

OLT Advance Series Tank Mounted Digital Fire Protection Air Compressors

MODEL: OLTV12016AC

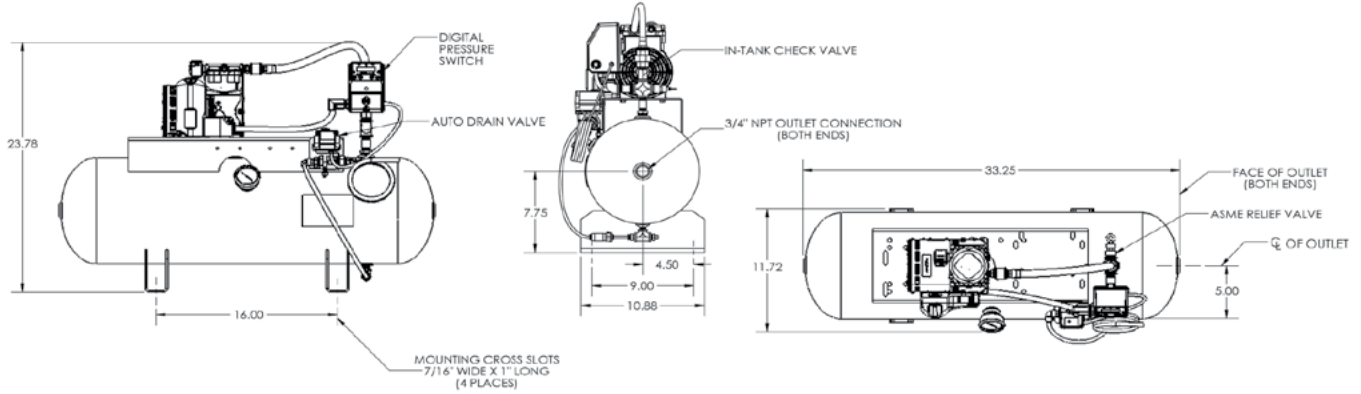

MODEL: OLTV25033AC

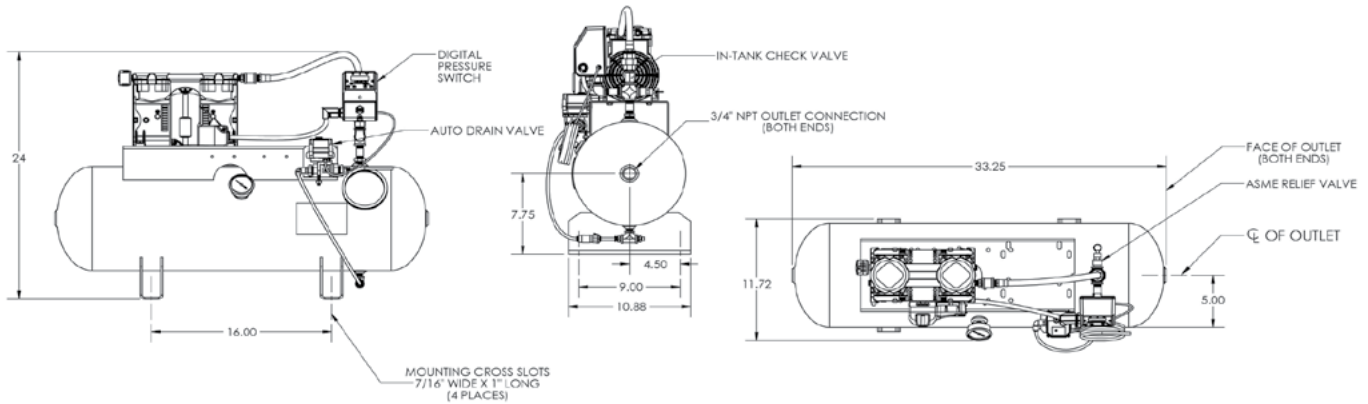

MODELS: OLTV40050AC | OLTV50075AC | OLTV600100AC

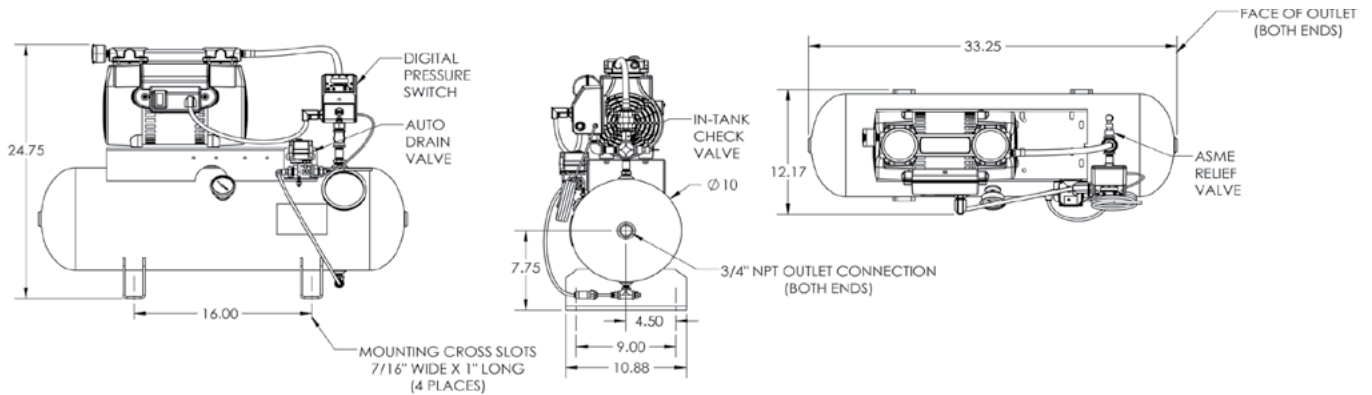

OLT Advance Series Tank Mounted Digital Fire Protection Air Compressors Accessories

VAPOR PIPE SHIELD



Vapor Pipe Shield is a Patented and UL Listed innovative solution for the prevention of corrosion in Dry-Pipe & Pre-Action Fire Sprinkler Systems.

AIR MAINTENANCE DEVICE



Part # AMD-1

The AMD-1 regulates the volume of air being delivered to the sprinkler system by the air compressor.

Per NFPA 13 - An Air Maintenance Device is required on every dry system unless the air compressor has a capacity less than 5.5 ft³/min at 10 PSI.

MOTOR LINE STARTER



Thermal Overload Protection

MAX HP	SINGLE PHASE MOTOR LINE STARTERS			
	115V	208-230V	Size	Model
1/3 HP	1 HP	00	MG00A	
1 HP	2 HP	0	MGX0A	
2 HP	3 HP	1	MG01A	
3 HP	5 HP	1P	MG15A	

When Ordering a Motor Starter you must specify HP, Voltage & Phase.