

# Complete Wiring Instructions for LTV1300300 | LT1300300 | L1300300 Lubricated Compressor

**LT** *Advance*  
Series



**LT** *Plus*  
Series



**L** *Plus*  
Series



**Section 1 – Introduction / Warnings**

**Section 2 – Wiring for Single Phase**

**Section 3 – Wiring for Three Phase**

## Introduction

General Air Products, Inc. has been an industry leader in quality products and customer service since its creation in 1936. Our persistent effort in meeting the needs of our customers assures that we will continue to lead in these areas. In keeping with these ideas we bring you this comprehensive wiring manual.

Inside you will find pictures and detailed instructions on how to properly wire your Lubricated Tank Mounted Air Compressor.

If you have any questions or problems during the installation process please call us toll free at **1-800-345-8207**.

## Warnings

- All electrical work must be completed by qualified electrician personnel, familiar with local and national codes.
- Motors are Factory wired. Connections for low or high voltage must be set by the installing personnel.
- All units are controlled by the pressure switch. Ensure that the incoming power supply is wired to the pressure switch.
- Magnetic Starters are recommended for all units and are required by electrical code for all Three (3) phase units.
- To ensure proper voltage to the compressor, a voltage reading **MUST** be taken while the compressor is running. We also recommend taking a voltage reading while the compressor is re-starting under load to verify the electrical service capacity.
- The current (amps) drawn by the compressor should be checked in conjunction with above. Starting and re-starting current loads will be higher initially than full load current. Our recommended wire sizes take this into account.
- Adjusting the pressure switch voids warranty – **CONSULT FACTORY**. Adjusting the pressure switch to a higher pressure could overload the motor.
- Beware – Capacitors hold **HIGH** Voltage. Do not handle.
- Motors are NEMA rated, which means they will operate at +/- 10% of name plate rating. The 10 percent applies to low and high voltage, but not 208v. This means motors wired for 208v/230v will operate between 207v and 253v. 200v motors available – consult factory.

**If you experience ANY electrical problems,  
Contact the factory IMMEDIATELY by calling 1-800-345-8207**

## Section 2

# Wiring Instructions for L(T)(V)1300300 Model Number: L(T)(V)1300300A

**High Voltage 208–230v**

**NOTE:** Our Model LT1300300 is not available in low voltage single phase. The LT1300300 is only available in 208-230v.

If you require a model of this size in 115v, Single Phase, please contact our customer service representatives for information.

### Model 1300300 – Single Phase 208–230v

SHOWS PROPER ROTATION - CLOCKWISE WHEN VIEWED FROM THE BACK OF THE MOTOR

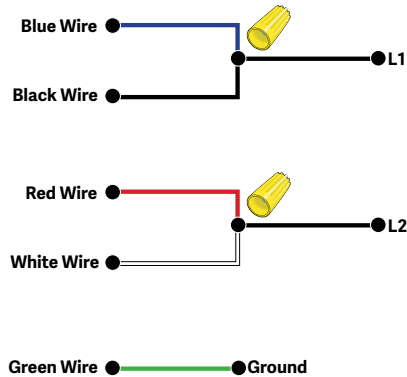

Blue Wire Black Wire White Wire Orange Wire Yellow Wire Green Wire

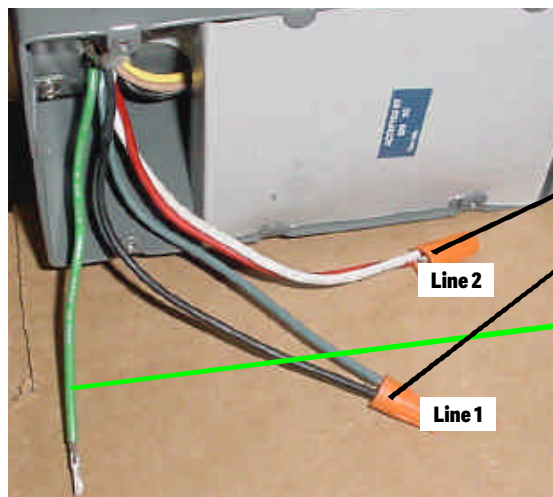

### Section 3

## Wiring Instructions for L(T)1300300 Model Number: L(T)1300300B

#### Low Voltage 208-230v

##### Model 1300300 – Three Phase 208-230v

SHOWS PROPER ROTATION - CLOCKWISE WHEN VIEWED FROM THE BACK OF THE MOTOR  
TO REVERSE ROTATION, INTERCHANGE ANY TWO LEADS

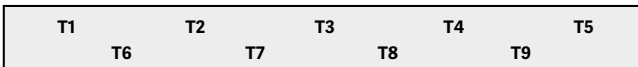
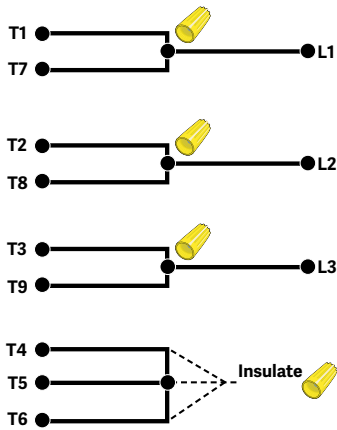

#### High Voltage 460v

##### Model 1300300 – Three Phase 460v

SHOWS PROPER ROTATION - CLOCKWISE WHEN VIEWED FROM THE BACK OF THE MOTOR  
TO REVERSE ROTATION, INTERCHANGE ANY TWO LEADS

