



Quiet, Tank Mounted Air Compressors for Dry Pipe & Pre-Action Sprinkler Systems

QLTV250

Introducing the most advanced Fire Protection Air Compressors ever built!

The Q Advance Series Tank Mounted Air Compressors Feature an all-new, UL 508 Listed, General Air Products Digital Pressure Switch. Designed to run at an average of 58 dBA, this is a 20 dBA drop from our standard OL Series. The Q Advance Series Air Compressors are specifically designed to fill dry pipe and pre-action fire sprinkler systems to supervisory pressure within 30 minutes per NFPA 13.



New Digital Pressure Switch:

The ONLY UL Listed Digital Pressure Switch in the Fire Protection industry designed and built by the compressor manufacturer themselves.

Displays Pressure Readings, Run Hours, Amps, Cycles, and is extremely easy to adjust pressure settings in the field. The Digital Pressure Switch also actuates an Automatic Drain Valve. (Tank mounted units only)

All tank mounted compressors require an Air Maintenance Device to regulate system pressure.

The Q Advance Series With A Digital Pressure Switch

- Whisper Quiet Motor
- Oil-Less Piston Compressor
- UL Listed, Digital Pressure Switch
- Fully Automatic Tank Drain Valve
- Includes Vibration Pads, 30" Stainless Steel Flex Hose & Union
- ASME Pressure Safety Valve
- Bubble Tight Air Check Valve
- Pre-Wired & Pre-Tested
- Lifetime Technical Support

System Capacity (gal)* @ 40 PSI	Model Number	Decibel Rating (dBA)	CFM @10 PSIG	Motor HP	Voltage (volts)	Amperage (amps)		Recommended Wire Size (gauge)			Unit Weight (lbs)
						FLA	Start Up	25' Run	50' Run	100' Run	
135	QLTV135-A	55	1.66	1/4	115	3.9	23.4	12	12	12	93
250	QLTV250-A	58	2.72	1/2	115	7.7	46.2	12	12	10	100
500	QLTV500-A	61	5.4	1	115	12.2	73.2	12	10	8	115

* System Capacity based on 30min fill-time at 70° F system temperature.

Note: A listed Air Maintenance Device must be installed in conjunction with all Tank Mounted air compressors.

Note: All information is subject to change without notice. Consult factory for most up-to-date product details.

WARNING: Cancer and Reproductive Harm - www.p65warnings.ca.gov

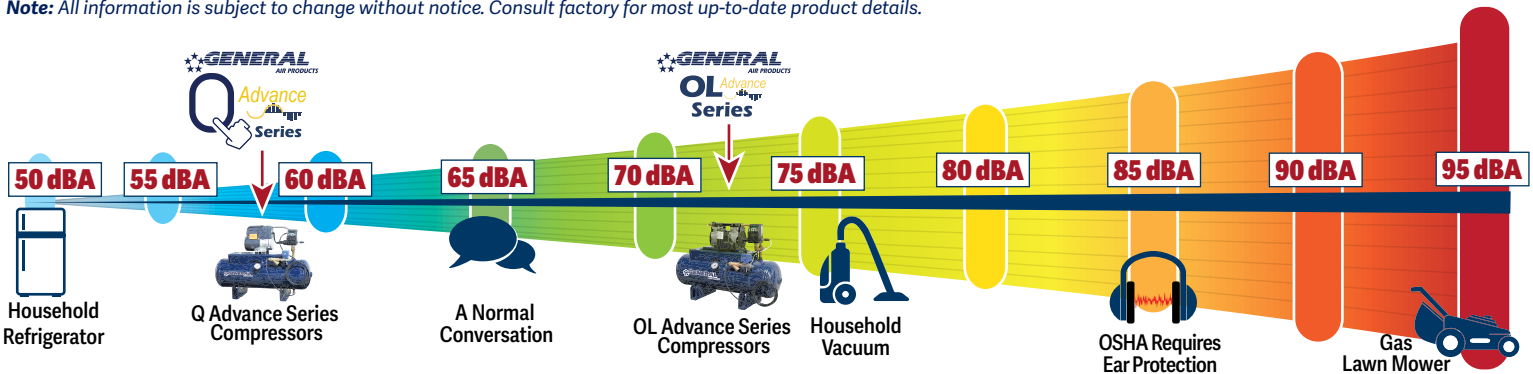

Note: All General Air Products compressors are OSHA compliant and und 85 dBA.

MODEL:
QLTV135-A – 115V/1Ph/60Hz

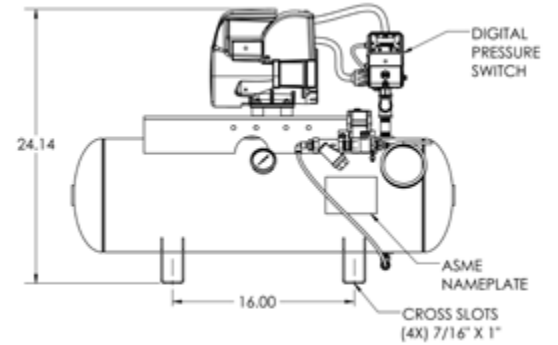
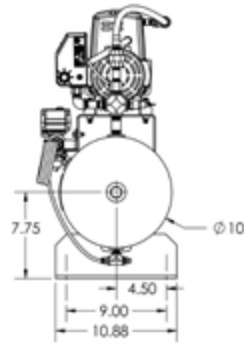
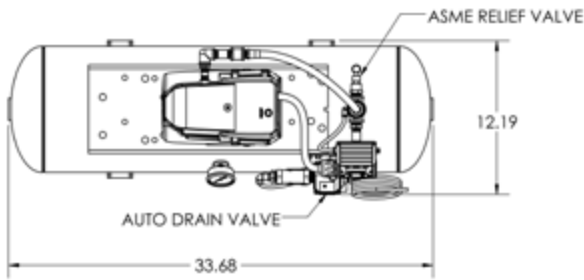

MODEL:
QLTV250-A – 115V/1Ph/60Hz

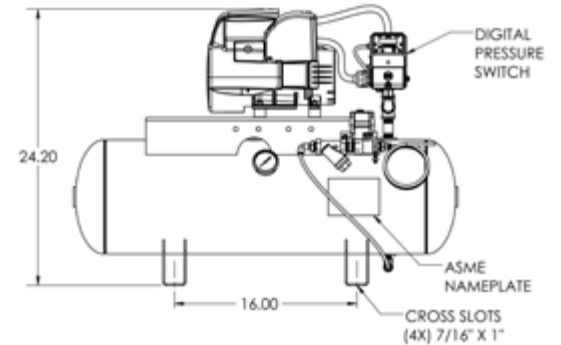
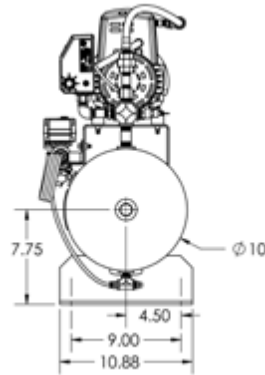
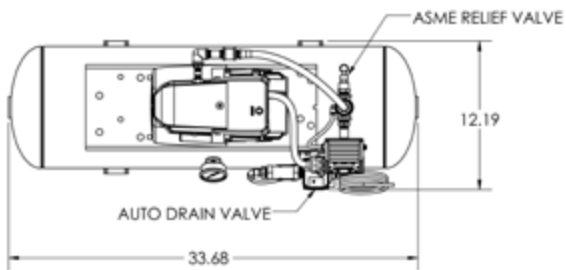

MODEL:
QLTV500-A – 115V/1Ph/60Hz

