



Dry Air Pac®

ENGINEERED COMPRESSED AIR DRYING SYSTEMS
FOR DRY PIPE SPRINKLER SYSTEM CORROSION MITIGATION
AND COLD STORAGE / FREEZER ROOM APPLICATIONS

Installation, Operation and Maintenance Manual MODELS DAPV500 & DAPV2000



Model Number	30 min. System Capacity	60 min. System Capacity	Compressor HP	Approx. Weight
DAPV500	500 Gallon	1000 Gallon	1	205 lbs.
DAPV2000	2000 Gallon	4000 Gallon	5	410 lbs.

For Technical Support, Call 1-800-345-8207
Hours of Operation: 8AM-5PM Eastern, Monday-Friday

Unit Serial Number: _____

Installation Date: _____



Table of Contents

1	Safety & Warnings	4
1.1	General Safety Information	4
2	Specifications	4
2.1	General Arrangement Model DAPV500	5
2.2	General Arrangement Model DAPV2000	6
2.3	Electrical Schematic – 100-240V, 1PH, 50-60Hz	7
2.4	Electrical Schematic – 190-600V, 3PH, 50-60Hz	8
3	System Description	9
3.1	Description of Operation	9
3.2	Dryer Operating Sequence	10
3.3	Filter Operation	13
4	Installation Instructions	13
4.1	Location	13
4.2	Connecting Voltage.....	14
4.3	Prior Run Time.....	15
4.4	Inlet Air Filter.....	15
4.5	DAPV Outlet	16
4.6	Air Maintenance Device	16
4.7	Auto Drain Valve.....	16
5	Start-Up Instructions	17
6	Maintenance	19
6.1	Compressor Oil Instruction DAPV2000	19
6.2	Filter Cartridge Replacement	20
6.3	Desiccant Replacement	21
6.4	Setting Pump Head Bolt Torque DAPV2000	22
7	Control Panel	22
7.1	Using the Control Panel	22
7.2	Control Panel Alarms	24
7.3	Resetting an Alarm	24
8	Trouble Shooting Guide	25
9	Warranty Poilcy	26

1 Safety & Warnings

1.1 General Safety Information

This manual contains information that is very important to know and understand. This information is provided for SAFETY and to PREVENT EQUIPMENT PROBLEMS. To help recognize this information, observe the following symbols.



Danger indicates an imminently hazardous situation which, if not avoided, WILL result in death or serious injury.



Warning indicates a potentially hazardous situation which, if not avoided COULD result in death or serious injury.



Caution indicates a potentially hazardous situation which, if not avoided, MAY result in minor or moderate injury.



Notice indicates important information, that if not followed may cause damage to equipment.

2 Specifications

Model	DAPV500	DAPV2000
System Capacity	500 Gallons	2000 Gallons
Compressor HP	1	5
Dryer Rating CFM	4.2	14.2
Current Load 460V 3 PH	2.5 Amps	6.3 Amps
Current Load 208-230V 3 PH	5.0 Amps	12.6 Amps
Current Load 115V 1 PH	15 Amps	N/A
Current Load 208-230V 1 PH	7.5 Amps	N/A
Wire Size 460V	12 GA	12 GA
Wire Size 230V	12 GA	10 GA*
Approximate Weight	205 lbs.	410 lbs.

*IF UNDER 50' RUN 12 GA CAN BE USED, HOWEVER, CHECK VOLTAGE WHILE RUNNING TO ENSURE NO UNDERVOLTAGE CONDITION EXISTS. FOR RUNS OVER 100' INCREASE WIRE SIZE TO CORRECT FOR VOLT DROPS.

2.2 General Arrangement Model DAPV2000

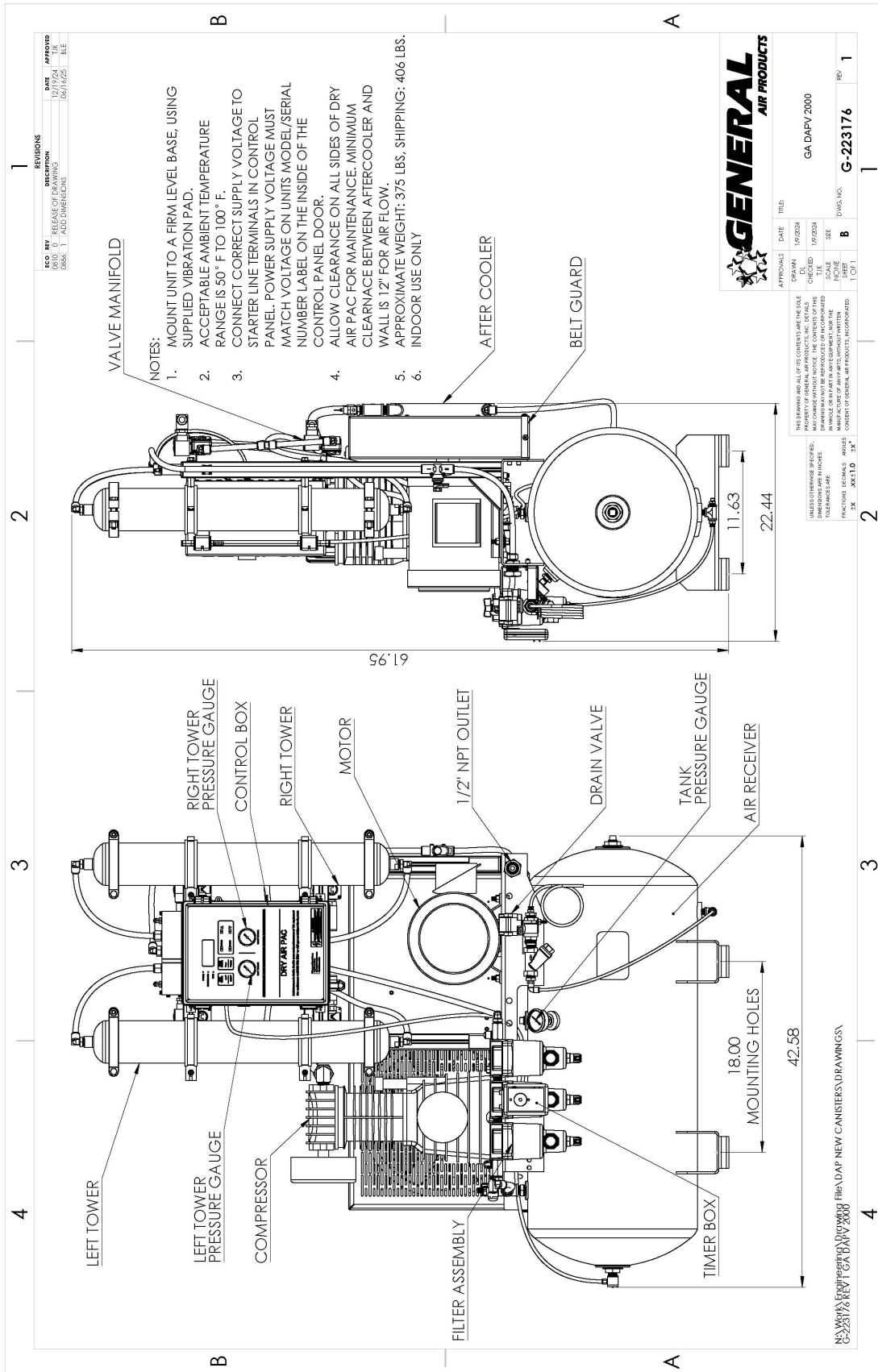

3 System Description

The following is a description of the operation of the DRY AIR PAC.

Typically, air is drawn into the compressor intake through the threaded inlet filter.



NOTICE

These units have been FM Approved with air not being drawn from the freezer room. Therefore, we do not recommend they be connected to the freezer room.

If required by the AHJ, air is drawn in from the cold room through the inlet filter installed inside the cold room. This air then travels to the compressor intake via 1 1/2" minimum line size piping.

3.1 Description of Operation

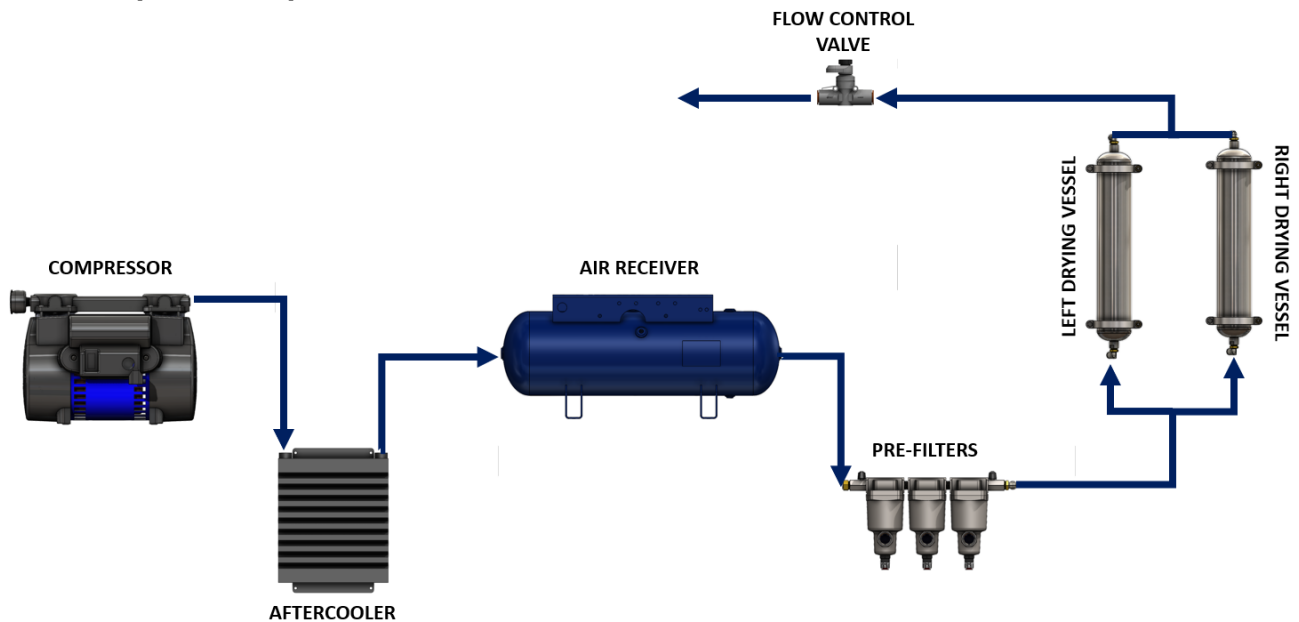

Figure 1. Dry Air Pac Flow Diagram

Air is drawn into the compressor intake and compressed through the compression cycle. The air then flows into the air-cooled aftercooler where ambient air pulled over the coil cools the hot compressed air.

Water in the compressed air condenses out of the air as it cools and flows into the receiver. A check valve in this line prevents back flow to the compressor. The water settles to the bottom of the receiver and is discharged from the receiver when the automatic drain valve opens.

Air then leaves the receiver and goes into the pre-filter assembly where entrained oil is removed. The air then travels to the dryer inlet. The air is diverted to one drying vessel by way of two solenoid valves. The air travels upwards through the desiccant bed and exits through the top of the vessel. A portion of the dried air is diverted to the opposite vessel by way of a fixed orifice.

The purge air enters the top of the off-stream tower and travels downward to pick up the water molecules from the desiccant as the pressure drops to atmosphere. The wet purge air exits the bottom of the vessel and is vented to atmosphere by way of the purge mufflers. The mufflers quiet the discharging air and reduce the noise when the towers depressurize. The mufflers are removable for cleaning with soap and water periodically. Cleaning will ensure no build up, which will create back pressures in the vessels and decrease dryer performance. Both inlet and outlet of the vessels have screens to retain the desiccant.

3.2 Dryer Operating Sequence

The dryer operates on a 4-minute total cycle. There are four valves on the inlet manifold, and a shuttle valve on the outlet. The shuttle valve will sequence automatically with the operation of the inlet valves. SV1 and SV2 are the inlet valves to the towers, SV3 and SV4 are the opposite purge valves such that when the left tower is drying and its inlet valve is open, the purge valve on that tower is closed.

With the unit turned on and the tank pressurized, air is ready to be used from the unit. As air is withdrawn from the unit into the sprinkler system, the receiver pressure will drop and signal the compressor to start. As the compressor runs, the dryer timer begins. The drying tower is indicated by a light on the front of the panel. The drying tower will show receiver pressure and the opposite tank, when purging, will show no pressure. When repressurizing prior to switch over, it will rise to receiver pressure. The dryer cycle timer runs only when the compressor is running and accumulates time so that the length of the cycle on each tower stays within the normal time cycle and does not saturate one desiccant bed. Purge valves are only open when the compressor runs. This minimizes compressor run time.

The frequency of change for the oil, filter elements and desiccant are highly dependent upon the following:

- Number of times the unit must operate to satisfy the system air requirement. The tighter the system, the less the unit will have to run.
- Cleanliness of the environment in which the compressor is located.
- Maintenance schedule for the equipment.



When the desiccant is replaced, all filter elements and oil should also be changed at that time if they have not been already. At a minimum the oil and filters should be changed every 750 run hours.

3.2.1 Scenario 1: Left Tower Drying Right Tower Purging. 0 - 1min. 30sec.

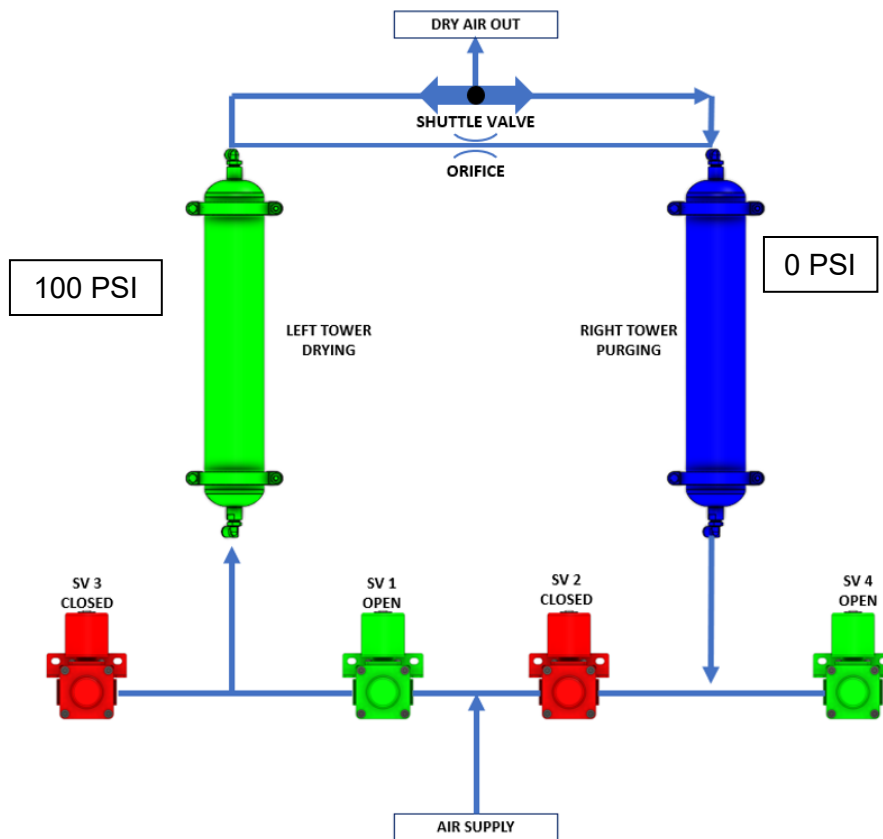

3.2.2 Scenario 2: Left Tower Drying Right Tower Repressurizing. 1min. 30sec. – 2min.

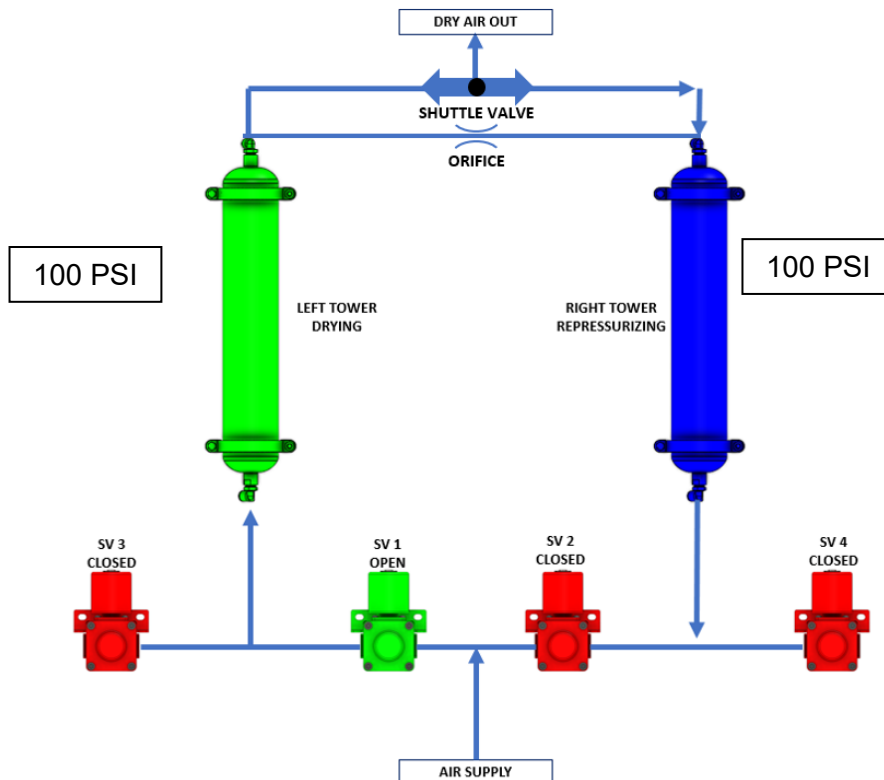

3.2.1 Scenario 3: Right Tower Drying Left Tower Purging. 2min. - 3min. 30sec.

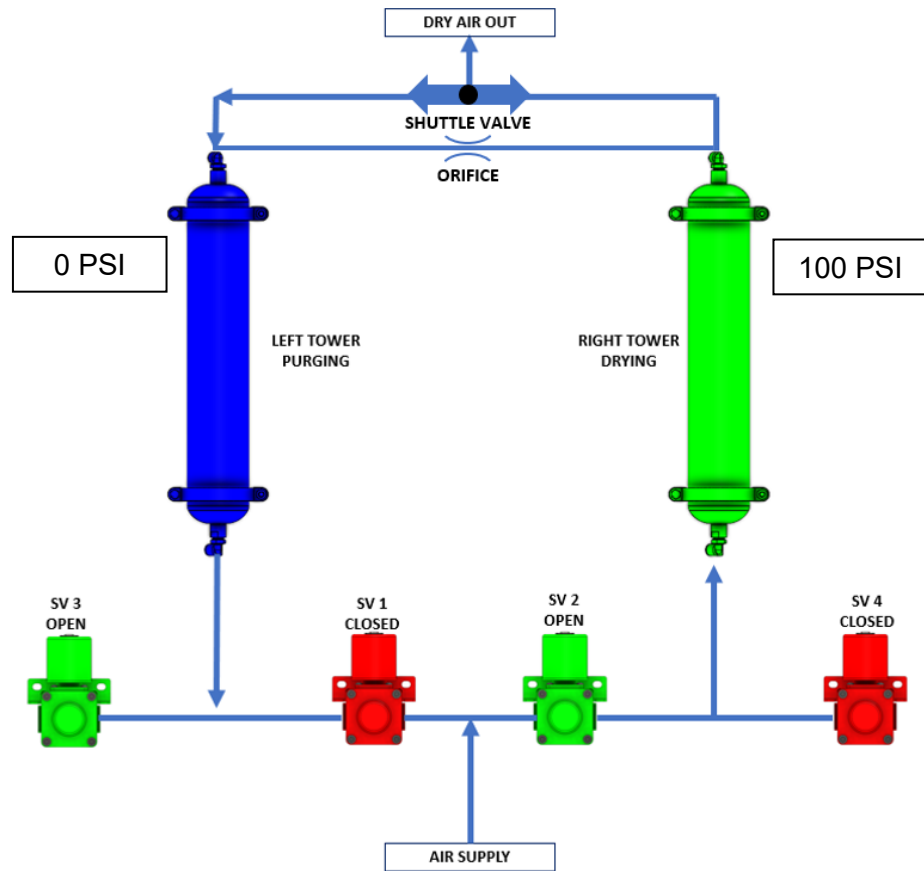

3.2.2 Scenario 4: Right Tower Drying Left Tower Repressurizing. 3min. 30sec. – 4min.

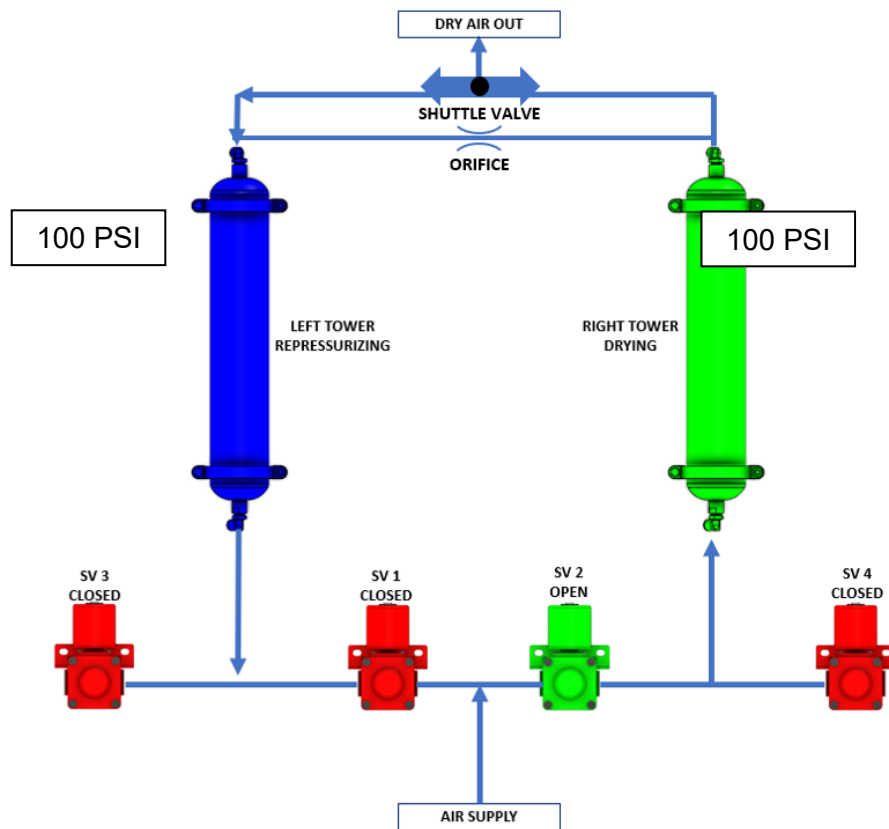

3.3 Filter Operation

The first in line filter is for bulk water removal. This is known as a water separator. The 2 following filters protect the desiccant dryer from oil carryover from the compressor. The filters have a built-in automatic drains, which will expel accumulated oil or moisture from the bottom of the bowl.

4 Installation Instructions

4.1 Location

Install DRY AIR PAC in a clean, dry location, with ambient temperatures always above 50° F, adjacent to the sprinkler system piping outside the cold room.



When a Dry Air Pac is supervising more than one system, ensure each system falls under the model's rated air fill capacity. Consult factory for further sizing recommendations.

The unit must be accessible on all sides for air flow and servicing all major components. The unit must be leveled and anchored to the floor (the vibration isolators supplied with the unit MUST be utilized). If the location is below freezing at any time the unit must be enclosed in a separate, heated enclosure to keep the temperature above 50° F.



Do not install the Dry Air Pac in an area where ammonia vapors or similar contaminants exist. The equipment and desiccant can be damaged by ammonia and other vapors. Locate the Dry Air Pac to ensure no ammonia or other vapors are drawn into the intake.

4.2 Connecting Voltage

A pry out hole plug is supplied on the top and bottom of the DAP enclosure. Use a flat head screwdriver or pliers to remove the hole plug that is easiest to supply incoming power.

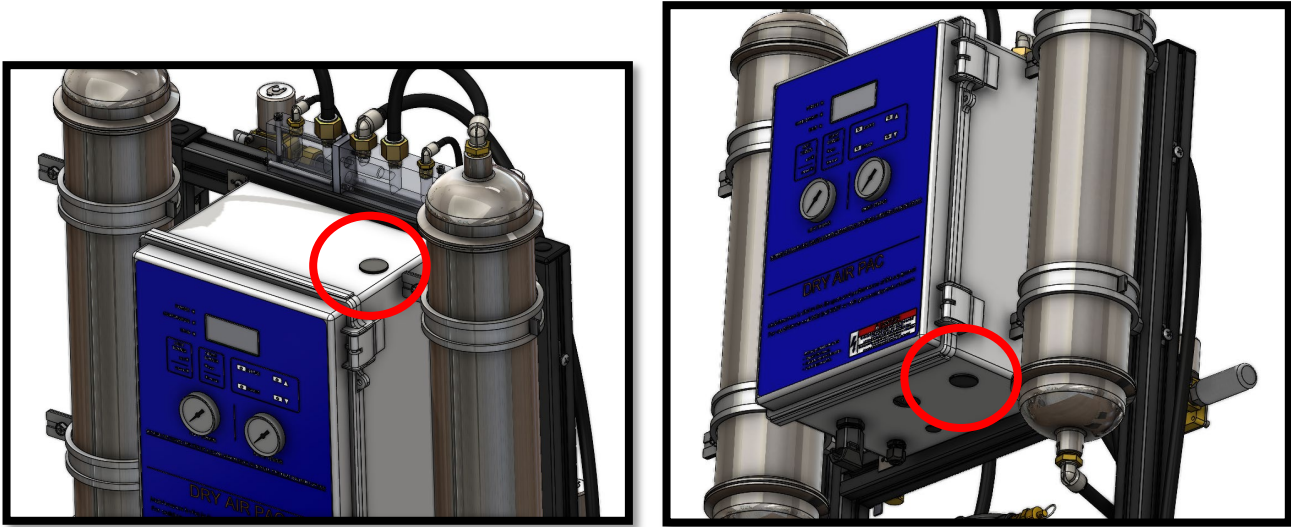

Remove either the top or bottom pry out hole plug to bring power into the enclosure of the DAPV.

Connect supply voltage to separate line terminals L1, L2, and L3 on the terminal blocks. Use stranded wire only. All wiring must conform to the National Electrical Code (NEC) and any local or building codes.



Wire size must be capable of carrying the unit load without dropping the voltage at the terminals below normal operating levels. Check incoming wire size; if there are any questions please contact us.

Each unit is run at the factory. Motor rotation will always need to be checked (3 phase units only). After connecting the power, wait for the compressor to turn on. An indicating arrow is on the compressor flywheel. If rotation is not correct on three phase units, reverse any two leads.

On single phase units refer to the motor nameplate, however it should not require changing as it has been run at the factory. If you feel this is required, please consult with factory personnel as there may have been changes made to the unit, which should be discussed with the factory PRIOR TO starting the unit. Please ensure sufficient power is available at the unit. Long feed line runs can cause voltage drops, which can affect the performance of the unit and damage the motor.



Only qualified electrical personnel should connect the unit.

4.3 Prior Run Time

The desiccant inside of the Dry Air Pac towers requires pre-conditioning prior to filling the system. Run the unit for 20 minutes before connecting to the sprinkler system. This will allow the desiccant to become conditioned to the proper dew point. A speed control valve is used to control the flow of air from the Dry Air Pac. Allow the air to flow out of the outlet shown in section 4.5 without connecting the outlet to the sprinkler system.



NOTICE

The Dry Air Pac should not run for more than 40 minutes in any given hour.



NOTICE

If you are connecting to an old piping system there may be existing leaks in the system which cause the compressor to cycle more frequently than 4 times per hour. If this is the case there are three suggestions: 1. Fix the leaks. 2. Add a second Dry Air Pac to provide enough air to bring the cycle times back to less than 4 times per hour. 3. Add a receiver, which can act as a storage buffer to supply more air to the system. This should be discussed with factory personnel, as it will only work in cases where minor leaks are involved.

4.4 Inlet Air Filter

The Dry Air Pac compressor is supplied with a removable, threaded inlet air filter so that if the AHJ requires air to be drawn from the cold room this can be done.



NOTICE

These units have been FM Approved with air not being drawn from the freezer room. Therefore, we do not recommend they be connected to the freezer room.

The Dry Air Pac is designed so that performance will not be adversely affected with the filter left in place directly on the compressor. If connected in the cold room, the piping back to the compressor must be 1 1/2" minimum pipe size for this run, reduced directly at the compressor inlet. This pipe must be heat traced and insulated. The inlet filter should be mounted on the inlet end of this pipe directly in the cold room. The interconnecting piping must be clean of any foreign matter, which may be drawn into the compressor and cause damage.

4.5 DAPV Outlet

The Dry Air Pac outlet is a ½” Female NPT bulkhead mounted on the top plate as shown below.

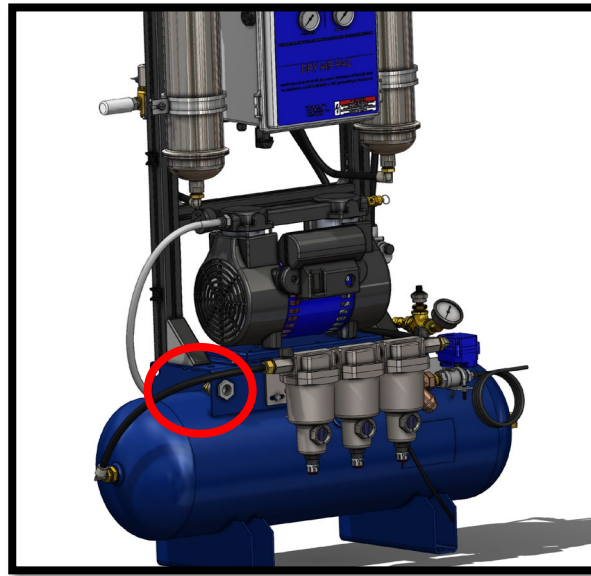

Use a backup wrench when connecting to the DAPV ½” FNPT outlet bulkhead. The DAPV500 is shown, on the DAPV2000, the bulkhead is on the opposite side of the tank top plate.

4.6 Air Maintenance Device

The Dry Air Pac requires a listed Air Maintenance Device for each riser on the sprinkler system. It must be adjusted to system requirements.

4.7 Auto Drain Valve

An automatic drain valve is installed on each unit. The drain valve timing is preset in the PLC and will open depending on compressor runtime. The valve can be manually opened by pressing the DRAIN button on the control panel.



Be sure to pipe the drain valve discharge to a location where the discharged air and water will not be a hazard to personnel. Follow local requirements for disposal of water and oil condensate.

5 Start-Up Instructions



Leaks in the piping system will affect the pump-up time of the system. The Dry Air Pac has been factory tested to produce the published capacity, for systems without leaks.

Prior to starting up the Dry Air Pac, the unit must be preconditioned as described in section 4.3.

With all the connections made as described in “Installation Instructions,” the unit is ready to start. With the valve ahead of the pre-filter assembly closed, turn the unit on. The compressor will start to fill the receiver tank and the tank pressure gauge will indicate the pressure. The unit will pressurize the receiver to approximately 105 psig and then shut off the compressor.

When the compressor stops, the unloader line will operate to bleed off the pressure in the line from the compressor to the receiver inlet, so that the compressor does not start loaded. Air exhausts from the small valve at the side of the control panel immediately after the compressor is shut off. This should not occur when the compressor is running or for long periods of time after the compressor shuts off. If this occurs, contact the factory.

Slowly open the valve ahead of the pre-filter assembly and pressurize the rest of the Dry Air Pac. The system Air Maintenance Device should be in fill mode. After filling the sprinkler system to its design pressure, close the fill valve on the AMD and open the AMD maintenance valves.

If water in the pipe is a concern, the piping system can be dried as follows: Open an inspection test point on the far end of the sprinkler system to allow the wet air in the sprinkler system to be purged out of the system. This leak should be adjusted to cause the compressor to run, after filling the system to pressure, no more than 4 times per hour. Allow this to run for 24 hours then close the inspection test port to allow the system to function normally. This procedure is an optional, extra step to ensure the piping system is as dry as possible and assumes proper pitch of piping and removal of standing water with low point drains as per NFPA 13.



If following the optional 24-hour drying procedure, remember to close the inspection port.

5.1 DAPV500 Fill Mode

For the DAPV500 model, a special Fill Mode can be utilized to increase the fill capacity of the compressor. Just before filling the sprinkler system, activate Fill Mode on the DAPV500 by holding the ENTER and UP arrow button for 3 seconds as shown below.

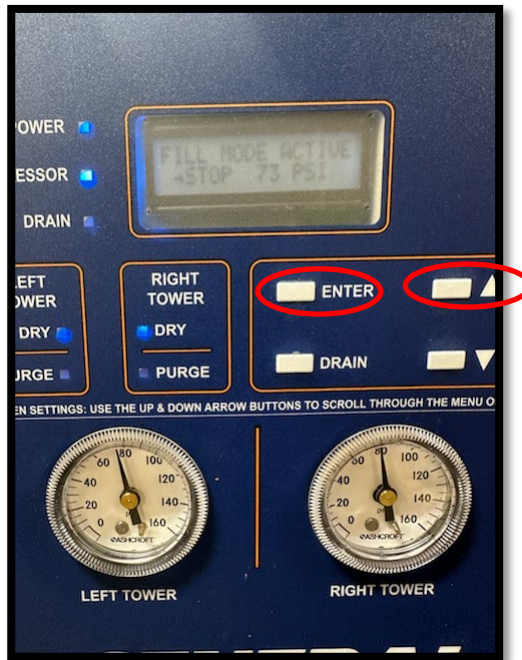

Hold ENTER and UP arrow button for 3 seconds to activate Fill Mode on the DAPV500.

The “DRY” LEDs will turn on and the “PURGE” LEDs will both be off for the left and right tower while in Fill Mode. Fill Mode will remain active for 30 minutes to completely fill the sprinkler system. Pressing the ENTER button while in Fill Mode will de-activate and return to normal operation.

6 Maintenance

Service kits are available as detailed below. Model and serial numbers are required when ordering service kits.

KIT# DAPV-MK-500	Compressor Intake Filter Element, 2 Coalescing Filter Elements, desiccant charge for both towers, gaskets, 2 AA batteries
KIT# DAPV-MK-2000	Compressor Intake Filter Element, 2 Coalescing Filter Elements, desiccant charge for both towers, gaskets, 2 AA batteries, compressor oil

6.1 Compressor Oil Instruction DAPV2000

Tools Needed: Funnel and rags

Parts Needed: GAP SPECIALLY FORMULATED COMPRESSOR OIL

1. REMOVE THE BRASS THREADED CAP SHOWN BELOW.

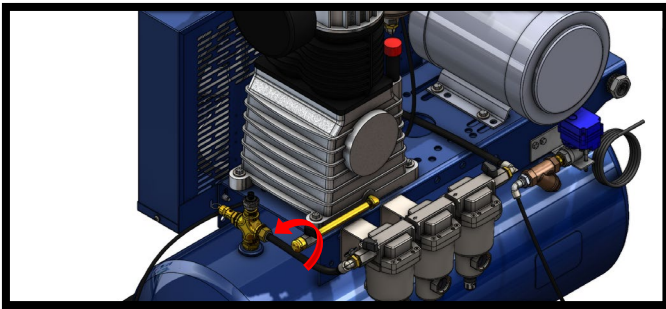

2. PLACE AN EMPTY 2 QUART CONTAINER UNDER THE BALL VALVE AND OPEN THE HANDLE. CLOSE THE VALVE WHEN COMPRESSOR IS DRAINED.

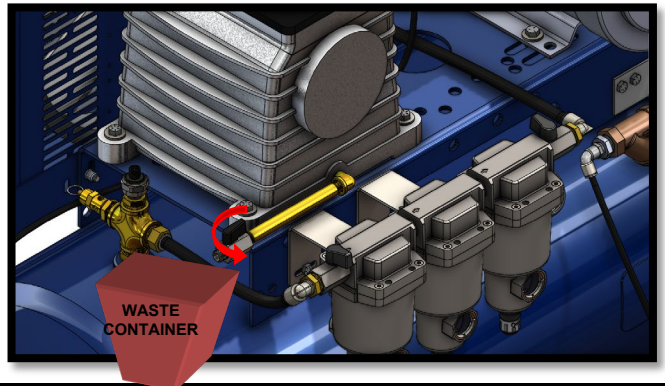

3. REMOVE THE THREADED BREATHER VENT CAP AND PLACE A FUNNEL INSIDE THE COMPRESSOR.

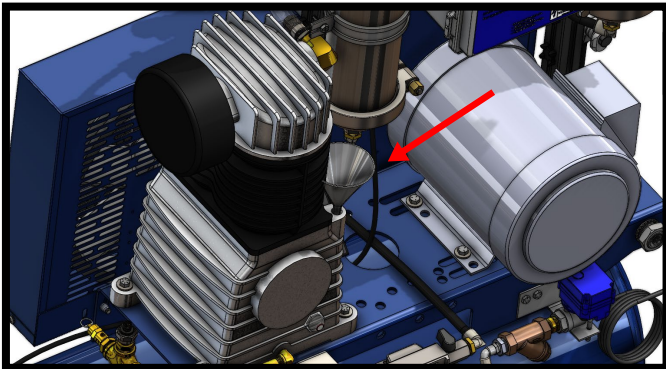

4. REINSTALL THE BRASS THREADED CAP. FILL THE COMPRESSOR WITH GAP SPECIALLY FORMULATED OIL APC01Q. FILL UNTIL OIL IS MID LEVEL IN THE RED CIRCLE SHOWN BELOW.

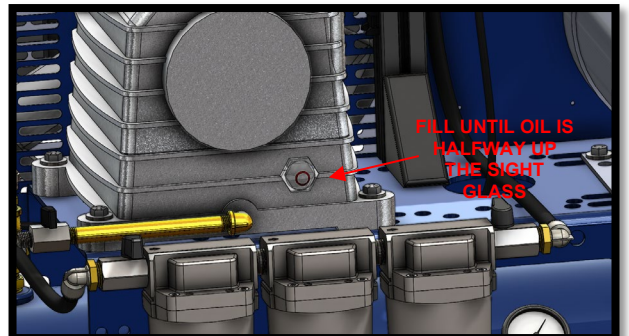

6.2 Filter Cartridge Replacement

Tools Needed: 4mm Allen Key

Parts Needed: GAP FILTER REPLACEMENT KIT

The DAPV comes equipped with 2 pre-filters that require annual maintenance.

1. ISOLATE PRESSURE FROM THE PRE-FILTER ASSEMBLY BY CLOSING BOTH BALL VALVES SHOWN BELOW.

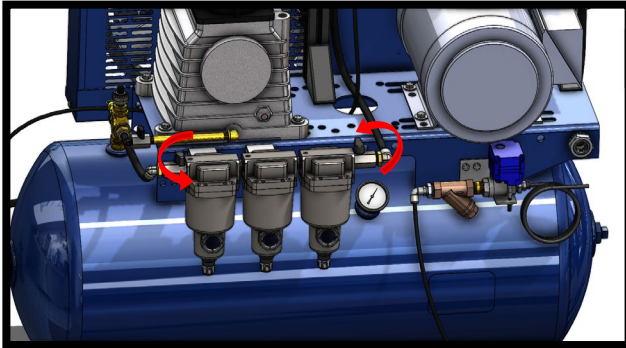

2. DEPRESSURIZE THE PRE-FILTER ASSEMBLY BY ROTATING THE FITTING AT THE BOTTOM OF ANY ONE OF THE 3 FILTERS. A SHORT PUFF OF AIR WILL BE RELEASED AND SHOULD IMMEDIATELY STOP.

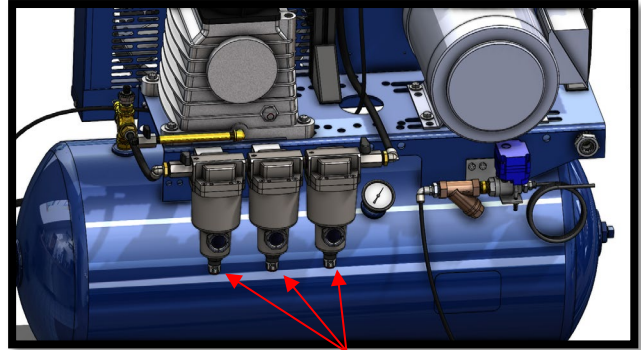

3. ONCE DEPRESSURIZED, REMOVE THE FILTER HOUSING ON FILTER #2 WITH A 4mm ALLEN KEY AS SHOWN.

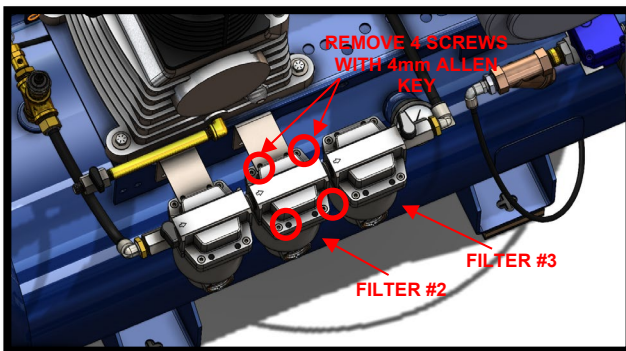

4. REPLACE THE FILTER ELEMENT AND REINSTALL FILTER #2 BOWL. REPEAT THIS STEP FOR FILTER #3. FILTER #1 DOES NOT REQUIRE MAINTENANCE.



REPLACE THIS FILTER ELEMENT IN FILTER #2 AND #3. FILTER #1 DOES NOT REQUIRE MAINTENANCE

5. OPEN THE BALL VALVES TO ALLOW THE PRE-FILTER ASSEMBLY TO REPRESSURIZE. CHECK FOR LEAKS.



DANGER

Filters must be completely depressurized. Pressure left in the filters can result in risk of injury.

6.3 Desiccant Replacement

Tools Needed: Pliers

Parts Needed: GAP DESICCANT REPLACEMENT KIT

The DAPV has 2 vessels containing desiccant to dry out the pressurized air. The desiccant must be serviced regularly to prevent wet air from travelling into the sprinkler system.

1. ISOLATE THE DAPV FROM THE SPRINKLER SYSTEM BY CLOSING THE VALVES ON THE AMD. CLOSE THE BALL VALVE TO THE FILTER ASSEMBLY AND ROTATE THE BOTTOM PORT OF 1 OF THE FILTERS.

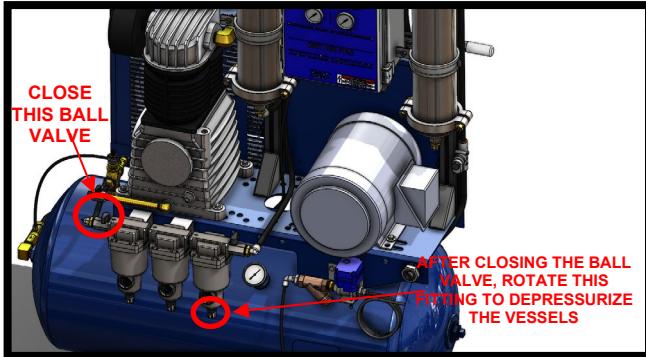

2. WATCH THE TOWER PRESSURE GAUGES AND WAIT FOR THEM TO REACH 0 PSI.

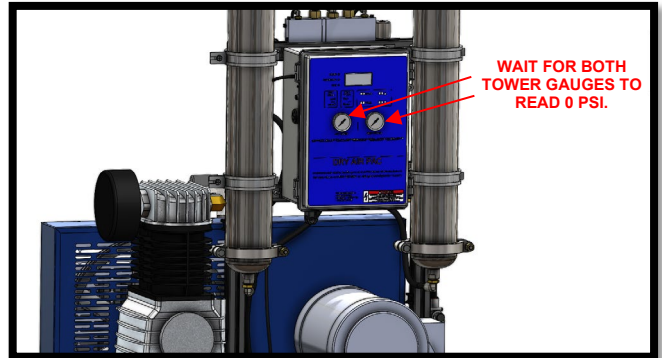

3. USE TWO 5/8" WRENCHES TO LOOSEN THE NUT ON THE TOP CLAMP OF BOTH VESSELS. REMOVE THE CLAMPS AND THE BOWLS.

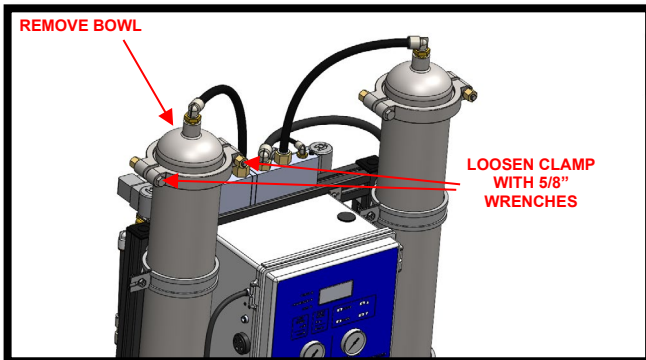

4. REMOVE AND DISCARD THE FILTER/GASKET. LIFT OUT AND DISCARD THE OLD DESICCANT BAGS.

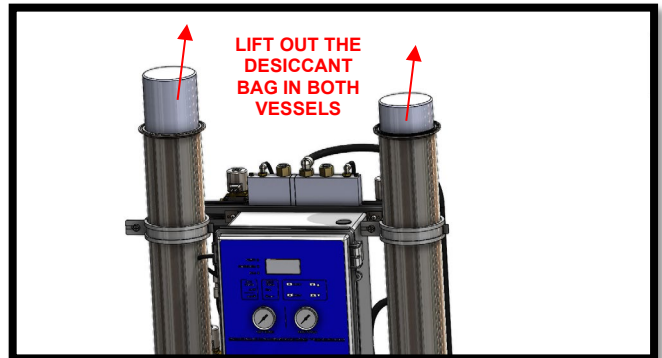

5. INSERT NEW BAGS AND FILTER/GASKETS INTO BOTH VESSELS. TIGHTEN BOTH VESSEL CLAMPS TO 20 FT-LBS. OPEN THE PRE-FILTER ASSEMBLY BALL VALVE TO REPRESSURIZE THE VESSELS AND CHECK FOR LEAKS. PUT THE AMD BACK INTO MAINTENANCE.



Towers must be completely depressurized. Pressure left in the towers can result in risk of injury.

6.4 Setting Pump Head Bolt Torque DAPV2000

Pump head bolts must be torqued to 35 ft/lbs after 40 hours of runtime. Follow the torque sequence shown below.

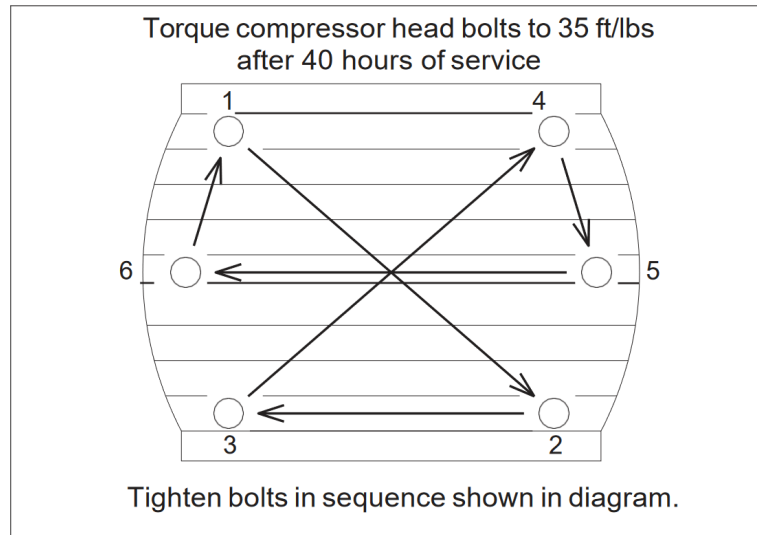

7 Control Panel

The DAPV is equipped with an embedded microcontroller, which actuates the solenoid valves, drain valve, compressor contactor, and reads pressure from a tank mounted pressure transmitter.

7.1 Using the Control Panel

When powering the unit on, the revision level of the firmware is displayed for a few seconds. The unit will then change to its default display as shown below.

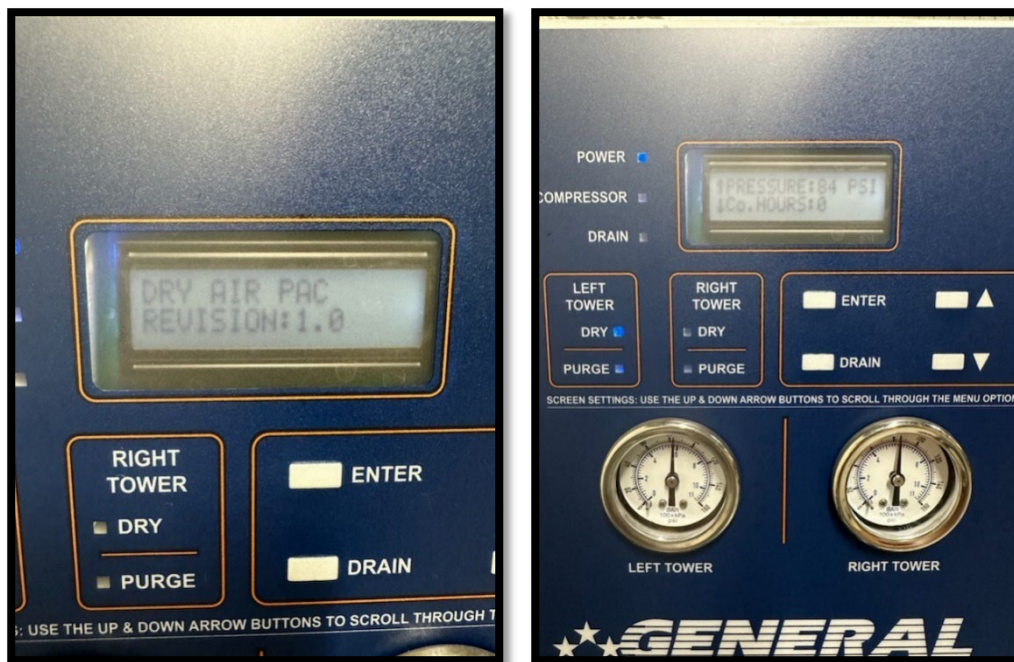

When powering the unit on, the revision level will be displayed as shown above

The default display after powering on

The up and down arrows can be used to toggle through all the information available on the display. Table 1 below is a description of all the available information and other controls on the control panel.

"PRESSURE"	Displays the system pressure in PSI
"Co. HOURS"	Displays the total number of compressor run hours since installation
"Co. CYCLES"	Displays the total number of compressor cycles since installation
"DRY CYCLES"	Displays the total number of dryer cycles since installation
"ALARM ACTIVE"	Only displayed when an alarm is active. When pressing ENTER, the alarms will be displayed.



"POWER ON LED"	This LED will indicate the unit power supply has power.
"COMPRESSOR ON LIGHT"	This LED will indicate the compressor should be running.
"DRAIN VALVE ON LIGHT"	This LED will indicate the drain valve should be open.
"DRY LIGHT"	This LED will indicate either the left or right tower is actively drying.
"PURGE LIGHT"	This LED will indicate either the left or right tower is actively purging.
"ENTER BUTTON"	This button is used to read and reset alarms
"UP & DOWN ARROW"	These buttons are used to navigate up & down through the LCD display
"DRAIN BUTTON"	Pressing this button will manually open the tank drain valve.
"TOWER GAUGES"	These gauges indicate the pressure in the left and right tower.

7.2 Control Panel Alarms

When an alarm becomes active on the DAPV, the display will automatically change such that the “ALARM ACTIVE” text will be displayed on the bottom row of the LCD as shown below. Press ENTER to view the active alarm(s).



When an alarm becomes active, the display will be as shown above. Pressing ENTER will view the alarms.

Use the up and down push buttons to scroll through the alarm list. At the bottom of the list is an option to “Reset” the alarm. All DAPV alarms are shown in the table below.

Alarm Descriptions	
“COMP. CYCLES”	The unit cycles more than 8 times within 1 hour.
“COMP. OVERLOAD”	The motor amp draw exceeded its limit and tripped the overload.
“COMP. EXCESS RUN”	The compressor exceeded its maximum allowable runtime of 45 minutes.

7.3 Resetting an Alarm

If an alarm trips, the ACTIVE ALARM text will be displayed on the bottom row of the LCD. Follow the steps below to reset the alarm.

Step 1: Press ENTER button when in an alarm state. This will take you to the Alarm List.

Note: For an alarm to be properly reset, the problem or reason for the alarm must be resolved or fixed.

Step 2: After resolving the problem, press ENTER to select RESET ALARM under the alarm list.

Step 3: After resetting an alarm, the alarm will disable.

Note: If the cause for the alarm was not addressed, it may become active again.

8 Trouble Shooting Guide

Symptom	Possible Causes	Corrective Action
Poor Dewpoint Performance	Low pressure on desiccant dryer.	<ul style="list-style-type: none"> • A factory marking is applied to the outlet flow valve. Verify the flow valve was not tampered with. • Check to see that Air Maintenance Device bypass valve has not been opened • Check compressor output to ensure compressor is running normally. • Check for leaks on the DAPV. The drain valve or filter drain ports may also be stuck open. Fix as needed.
	Water and/or oil in dryer.	Check pre-filter assembly and float drain operation
	Low purge flow.	Check orifice
	Desiccant contamination	<ul style="list-style-type: none"> • Check compressor intake is not in an area where chemicals can be drawn into the intake filter with air. • Check when the last time the desiccant was changed. Recommended frequency of change, every 3 years. • Check condition of desiccant. It should be pure white. Change desiccant if contaminated. • Check condition of pre-filters #2 and #3.
	High inlet temperature to dryer due to high ambient temperature.	Lower ambient temperature or move unit to area less than 100F
Tower Switch Failure	Solenoid Valve Failure	Check valve operating sequence. Replace valve.
Excessive Pressure Drop	Switching Valve Failure	Check tower operating sequence to verify and identify which valves are operating.
	Desiccant Breakdown	Change desiccant
	Clogged Filters	Change filter elements.
	Valve Closed	Open valve
Repressurization Failure or Purge Failure/ Tower Back-pressure	Orifice Clogged	Clean orifice
	Shuttle valve stuck	Replace
	Purge Exhaust Solenoid Failure	Check valve connection with power OFF. Solenoid valve light should be on when actuated.
Controller Screen Not On	Purge Exhaust Muffler Clogged	Clean or replace.
	Low voltage	Check voltage from 24vdc power supply

9 Warranty Policy

GENERAL PROVISIONS & LIMITATIONS

General Air Products, Inc. (the "Company") warrants to each original purchaser ("Purchaser") of its new products from the Company or its Authorized Distributor that such products are, at the time of delivery to the Purchaser, made with good materials and workmanship. No warranty is made with respect to:

1. Any product, which has been repaired or altered in such a way, in the Companies judgment, as to affect the product adversely.
2. Any product, which has, in the Companies judgment been subjected to negligence, accident, improper storage, improper installation or application.
3. Any product, which has not been operated or maintained in accordance with the recommendations of the Company.
4. Components or accessories manufactured, warranted and serviced by others.
5. Any reconditioned or prior owned product.

Claims for items described in 4. above should be submitted directly to the manufacturer.

WARRANTY PERIOD

The Company's obligation under this Warranty is limited to repair or, at its option, replacing during normal business hours at the designated facility of the Company, any part that in its judgment proved not to be as warranted within the applicable Warranty Period as follows.

COMPONENTS

All non-consumable components are warranted for 12 months from the date of purchase. Consumables are not covered under warranty. The unit must have been installed by either a factory authorized distributor or agent in accordance with the factory recommendations taking into account all other local site conditions not originally noted to the factory. The unit must be operated and maintained in accordance with the Factory recommendations and original design conditions. Failure to provide such proof of the above may void warranty.

LABOR TRANSPORTATION & INSPECTION

The Company will repair or replace any product or part thereof which in the Companies judgment is proved to be not as warranted. Labor costs are not covered under warranty.

All costs of transportation of product, labor or parts claimed not to be as warranted and, of repaired or replaced parts to or from factory shall be borne by purchaser. The Company may require the return of any part claimed not to be as warranted to one of its facilities as designated by the Company, transportation prepaid by Purchaser, to establish a claim under this warranty.

Replacement parts provided under the terms of the warranty are warranted for the remainder of the Warranty Period of the product upon which installed to the same extent as if such parts were original components.

DISCLAIMER

THE FOREGOING WARRANTY IS EXCLUSIVE AND IT IS EXPRESSLY AGREED THAT, EXCEPT AS TO TITLE, THE COMPANY MAKES NO OTHER WARRANTIES, EXPRESSED OR IMPLIED OR STATUTORY, INCLUDING ANY IMPLIED WARRANTY OR MERCHANTABILITY.

THE REMEDY PROVIDED UNDER THIS WARRANTY SHALL BE THE SOLE, EXCLUSIVE AND ONLY REMEDY AVAILABLE TO THE PURCHASER AND IN NO CASE SHALL THE COMPANY BE SUBJECT TO ANY OTHER OBLIGATIONS OR LIABILITIES. UNDER NO CIRCUMSTANCES SHALL THE COMPANY BE LIABLE FOR SPECIAL, INDIRECT, INCIDENTAL OR CONSEQUENTIAL DAMAGES, EXPENSES, LOSSES OR DELAYS HOWSOEVER CAUSED.

No statement, representation, agreement, or understanding, oral or written, made by any agent, distributor, representative or employee of the Company which is not contained in this Warranty will be binding upon the company unless made in writing and executed by an officer of the Company.

This warranty shall not be effective as to any claim which is not presented within 30 days after the date upon which the product is claimed not to have been as warranted. Any action for breach of this warranty must be commenced within one year after the date upon which the cause of action occurred.

Any adjustment made pursuant to this warranty shall not be construed as an admission by the Company that any product was not as warranted.

PROMPT DISPOSITION & RETURNS POLICY

The Company will make a good faith effort for prompt correction or other adjustment with respect to any product, which proves to be defective within the warranty period. Before returning any product, write or call the distributor, agent or authorized company from which the product was purchased, describing defect and giving date and number of original invoice, a well as proof of Factory supplied consumables and proof of scheduled maintenance. No products will be accepted for return without the Company issuing a "Returned Goods Authorization" (RGA) to the Purchaser and unless accompanied by a properly authorized RGA request form initiated by the Purchaser. Return freight must be prepaid and each returned product must have the RGA number clearly marked on the product. Title and risk of loss pass to buyer upon delivery to the common carrier.

PRODUCT SUITABILITY

Many States, Localities and Countries have codes and regulations governing sales, construction, installation, and/or use of products for certain purposes, which may vary from those in neighboring areas. While General Air Products, Inc. attempts to assure that its products comply with such codes, it cannot guarantee compliance, and cannot be responsible for how the product is installed or used? Before purchase and use of a product, please review the product application, and national and local codes and regulations, and be sure that the product, installation, and use will comply with them.



General Air Products, Inc.
118 Summit Drive
Exton, PA 19341
P: 610-524-8950
F: 610-524-8965

For Technical Support, Call 1-800-345-8207

Hours of Operation: 8AM-5PM Eastern, Monday-Friday