

THREE PHASE

80/100 PSI

PRE-WIRED WITH OVERLOAD PROTECTION

Oil-Less Tank Mount Fire Protection Air Compressors

for Dry Pipe & Pre-Action Sprinkler Systems.

General Air Products newly improved OLT Plus Series Oil Less Tank Mounted Fire Protection Air Compressors are specifically designed to fill dry pipe and pre-action fire sprinkler systems to Supervisory Pressure within 30 minutes per NFPA 13.

All tank mounted compressors require an Air Maintenance Device to regulate system pressure.

OLT Plus Series



Includes Vibration Pads, 30" Stainless Steel Flex Hose & Union.



System Capacity (gal)* @40 PSI	Model Number	CFM @10 PSIG	Motor HP	Voltage (volts)	Amperage (amps)		Recommended Wire Size (gage)			Tank Size	Unit Weight (lbs)
					FLA	Start Up	25' Run	50' Run	100' Run		
400	OLT400-B2S	4.85	1/2	208	4.8	33.6	12	12	10	10	98
	OLT400-B3S			230	4.8	33.6	12	12	12		
	OLT400-B4S			460	3.4	23.8	12	12	12		
500	OLT500-B2S	6.06	3/4	208	4.8	33.6	12	12	10	10	98
	OLT500-B3S			230	4.8	33.6	12	12	12		
	OLT500-B4S			460	3.4	23.8	12	12	12		
600	OLT600-B2S	7.28	1	208	4.8	33.6	12	12	10	10	98
	OLT600-B3S			230	4.8	33.6	12	12	12		
	OLT600-B4S			460	3.4	23.8	12	12	12		
915	OLT915-B2S	11.1	1 1/2	208	6.6	46	12	10	8	20	135
	OLT915-B3S			230	7	49	12	12	12		
	OLT915-B4S			460	3.5	24.6	12	12	12		
1100	OLT1095-B2S	13.34	2	208	9.2	64.4	12	10	8	20	135
	OLT1095-B3S			230	9.2	64.4	12	12	12		
	OLT1095-B4S			460	4.6	32.2	12	12	12		

Features and Benefits

- UL 1450, Supplement SC
- CSA C22.2 No.68-Canada
- Oil-Less Piston Compressor
- UL Listed, Pre-Set Pressure Switch
- Fully Automatic, Direct Drive
- ASME Pressure Safety Valve
- Bubble Tight Air Check Valve
- Pre-Wired & Pre-Tested
- Lifetime Technical Support
- Automatic Tank Drain Valve
- Annual Automated Maintenance Reminders
- Includes Vibration Pads, 30" Stainless Steel Flex Hose & Union

* System Capacity based on 30min fill and at 70°F system temperature.

Note: A listed Air Maintenance Device must be installed in conjunction with all Tank Mounted air compressors.

Note: All compressors are pre-wired with overload protection.

Note: All information is subject to change without notice. Consult factory for most up-to-date product details.

WARNING: Cancer and Reproductive Harm – www.p65warnings.ca.gov

System Capacity (gal) by System Pressure

Model Number	@20 PSI	@30 PSI	@40 PSI	@50 PSI	@60 PSI	@70 PSI	@80 PSI	@90 PSI	@100 PSI
OLT400-B	930	595	400	325	255	215	180	155	135
OLT500-B	1030	655	500	360	290	240	200	170	145
OLT600-B	1250	790	600	435	350	285	240	210	180
OLT915-B	2190	1325	915	680	525	420	340	280	240
OLT1095-B	2630	1625	1100	860	690	555	465	390	340

OL Plus Series Tank Mount, Three Phase Fire Protection Air Compressors

MODELS: [OLT400-B](#) | [OLT500-B](#) | [OLT600-B](#)

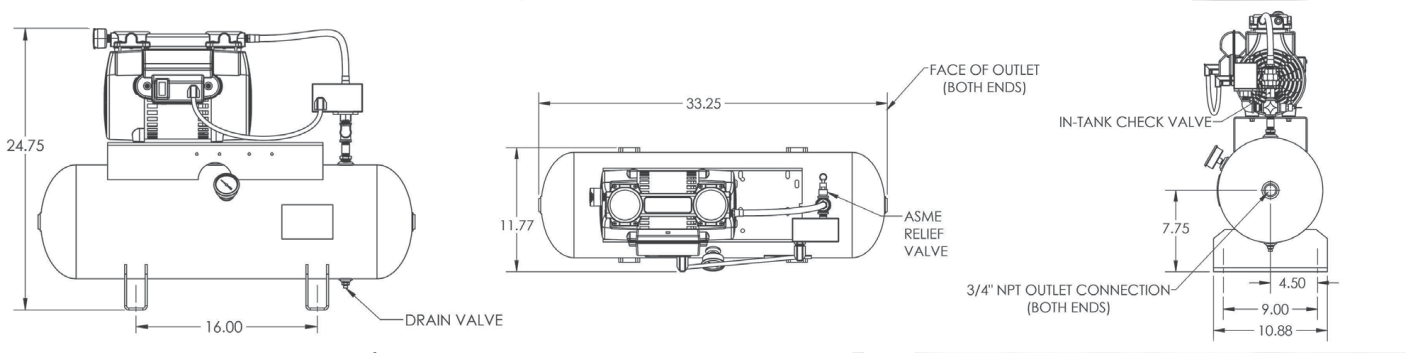

MODELS: [OLT915-B](#) | [OLT1095-B](#)

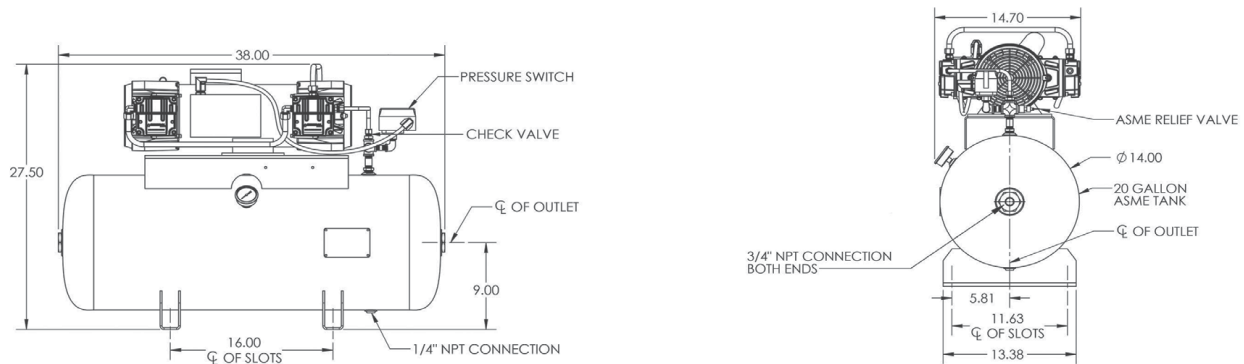

OLT Plus Series Tank Mounted Fire Protection Air Compressors Accessories

VAPOR PIPE SHIELD



Vapor Pipe Shield is a Patented and UL Listed innovative solution for the prevention of corrosion in Dry-Pipe & Pre-Action Fire Sprinkler Systems.

[LEARN MORE](#)

AIR MAINTENANCE DEVICE



Part # AMD-1

The AMD-1 regulates the volume of air being delivered to the sprinkler system by the air compressor.

Per NFPA 13 - An Air Maintenance Device is required on every dry system unless the air compressor has a capacity less than 5.5 ft³/min at 10 PSI.

[LEARN MORE](#)

ANNUAL MAINTENANCE REMINDERS



We Make Maintenance Easy!

You can now sign up for maintenance reminders for all of your General Air Products Equipment and we'll send you reminders when your maintenance dates are approaching. It really is that simple!

[LEARN MORE](#)