

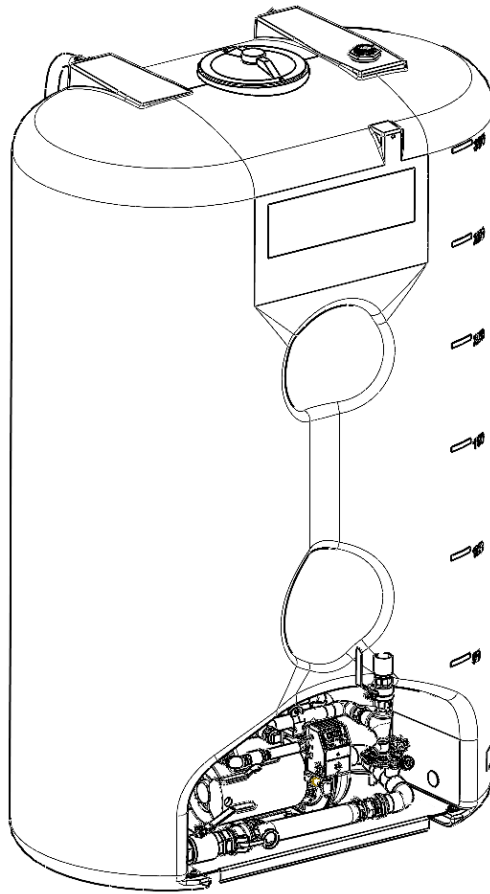

Residential Fire Protection Pump & Tank System
For NFPA 13D Applications

Installation, Operation & Maintenance Manual



Installation Date: _____ Contractor: _____

Person Installing: _____ For Emergency Service Call: _____

Table of Contents

Section 1 - Safety & Warnings

- 1.1 - Safety Guidelines
- 1.2 - Unpacking
- 1.3 - General Safety Information
- 1.4 - Water Tank Safety Information
- 1.5 - Water Tank Lid Safety Tie Down Instructions

Section 2 - System Description

Section 3 - Installation Instructions

- 3.1 - Initial Inspection
- 3.2 - Rigging & Moving
- 3.3 - Location & Installation
- 3.4 - Piping

Section 4 - System Testing & Training

Section 5 - Filling the Sprinkler System

Section 6 - Start-Up Checklist

Section 7 – Wiring Diagrams

Section 8 – General Arrangement Drawing

Section 9 – Troubleshooting

Section 10 – Warranty Policy

**IMPORTANT: ALL INFORMATION SUBJECT TO CHANGE WITHOUT NOTICE.
Consult factory for the most up to date version of this manual.**

- Please take the time to complete the forms on the front and back of this manual.
- Additional information may be found attached to the back of this manual.

Section 1 - Safety & Warnings

1.1 Safety Guidelines

This manual contains information that is very important to know and understand. This information is provided for SAFETY and to PREVENT EQUIPMENT PROBLEMS. To help recognize this information, observe the following symbols.



Danger indicates an imminently hazardous situation which, if not avoided, WILL result in death or serious injury.



Warning indicates a potentially hazardous situation which, if not avoided COULD result in death or serious injury.



Caution indicates a potentially hazardous situation which, if not avoided, MAY result in minor or moderate injury.



Notice indicates important information, that if not followed may cause damage to equipment.

1.2 Unpacking

After unpacking the unit, carefully inspect for any damage that may have occurred during transit. Make sure to tighten fittings, bolts, etc., before putting unit into service.

Do not operate unit if damaged during shipping, handling or use.

1.3 General Safety Information

1. Read all manuals included with this product carefully. Be thoroughly familiar with the controls and the proper use of the equipment
2. Follow all local electrical and safety codes as well as National Electrical Codes (NEC), Occupational Safety and Health Act (OSHA), and National Fire Protection Association (NFPA)
3. Only persons familiar with these rules of safe operation should be allowed to use the equipment.
4. Keep visitors away and NEVER allow children in the work area.
5. Wear safety glasses and use hearing protection when operating the unit.
6. Do not stand on or use the unit as a handhold.
7. Periodic inspection and test of this equipment is required. Consult your installer and local codes to meet all requirements.
8. Check all fasteners at frequent intervals for proper tightness.

**WARNING**

This product can expose you to chemicals including Cumene, which is known to the State of California to cause cancer and birth defects or other reproductive harm. For more information go to www.P65Warnings.ca.gov

Section 1 - Safety & Warnings

1.3 General Safety Information (Continued)



- Motors, Electrical Equipment and Controls can cause electrical arcs that will ignite a flammable gas or vapor.
- Never operate or repair in or near a flammable gas or vapor.
- Never store flammable liquids or gases in the vicinity of the system.



- For up-to-date fire protection information please consult the National Fire Protection Association at www.nfpa.org.



Use a backup wrench when adjusting the water inlet piping on the tank. There is a float and shutoff valve connected to the inlet bulkhead. Moving the inlet bulkhead without the use of a backup wrench will loosen the float and valve out of position. This will cause possible overflow of the tank.

1.4 Water Tank Safety Information

- Confined spaces must be considered hazardous. DO NOT enter tank at any time.
- Fill tank with water and hold for at least 5 hours PRIOR to use to identify leakage through unsecured fittings, shipping damage or manufacturing defects. The manufacturer's warranty of this tank is void unless upon installation of the tank, the tank is water pre-tested as a final test of suitability.
- DO NOT use for vacuum or pressure applications. Tank is supplied properly vented.
- Continuous operating temperatures above 140°F (60°C) are NOT RECOMMENDED. Consult factory for operating temperature above 100°F (38°C).
- Protect tanks from impact (especially sharp blows).
- Installation sites for tanks should be on a reinforced concrete pad. Soil sites for smaller tanks must be solid, stable and compacted. All sites must be level, flat, free of rocks or other objects, and above known flood plains.
- Weight of strainers, valves, hose or pipe must not be carried by the tank outlets.
- User is responsible for determining compatibility of chemicals with tank and fitting materials. TESTING IS RECOMMENDED. Tank should not be used for anything other than water.
- Use expansion joints or other flexible connection methods at all tank fittings to prevent damage from differential expansion and contraction of piping and tank. The use of rigid piping or the failure to provide for the expansion of the tank will void all warranties.
- Observe all local, state and federal codes.

Section 1 - Safety & Warnings

1.5 Water Tank Lid Safety Screw Instructions

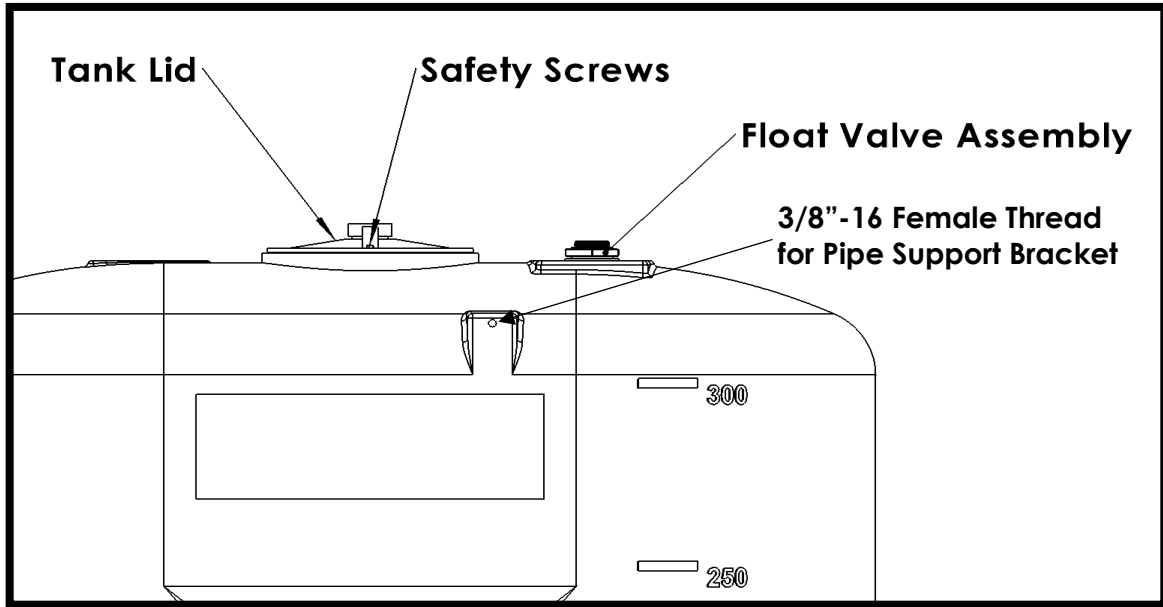

- For safety reasons the tank lid is secured with safety screws.
Do not remove safety screws in the tank lid. If screws are removed for service reasons, they must be reinstalled when work is completed.

Section 2 - System Description

This unit is a pump & tank package specifically designed for installation in residential / light commercial installations.



This system is used on the sprinkler system to supplement, or provide, from the tank, a sufficient volume of water to meet the system design limits (at the time of installation). If Code changes are made, you should consult your installer to ensure revisions are incorporated into your system as the code changes take effect.

The tank holds a given volume of water to be supplied to the sprinklers if they activate. The pump will turn on if the pressure, sensed by the pressure switch, drops to the lower set point (consult QC sheet). As long as the water pressure in the fire sprinkler system is above the lower set point the pump will not turn on.



The optional flow switch is designed to be tied into the alarm and control system. It incorporates an adjustable retard (time delay) to avoid false alarms. The installing technician should tie the flow switch, if installed, into the system as required by the AHJ or the system designer during initial installation.

This system was custom designed to meet given flow rates and set to activate at given pressures. Consult the design limit sheet or pump curve to verify the design criteria. If the design limit sheet has not been completed, contact your installer for the information.

Section 3 - Installation Instructions

3.1 Initial Inspection

When the equipment and accessories are received, they should be immediately inspected for shortages and damage. If the equipment has been damaged in shipment or shortages are noticed, immediately notify the carrier and file a claim. If hidden damage to the residential pump system is suspected, it is recommended that the system be filled with water as a leak check prior to rigging and/or final placement.

3.2 Rigging & Moving

The H2home unit was designed where the pump/tray assembly can be easily removed to lighten the weight during handling. Once the tank is in its resting place the pump/tray assembly can be easily reconnected and installation completed.

The exact method of handling and setting the residential pump system depends on the available equipment, the size of the unit, its final location and other variables. It is the rigger's or mover's responsibility to determine the specific method of safely handling each unit.



UNDER NO CIRCUMSTANCES SHOULD THE PIPING BE USED IN LIFTING OR MOVING THE SYSTEMS.

3.3 Location & Installation

Residential pump systems must be mounted indoors unless specifically ordered for special locations.



THE SYSTEM MUST BE INSTALLED LEVEL.



THE SYSTEM MUST BE KEPT ABOVE FREEZING (32° F) AT ALL TIMES.



THE ENTIRE SURFACE OF THE TANK BOTTOM MUST BE IN CONTACT WITH THE FLOOR SURFACE. NEVER ELEVATE THE TANK.

Section 3 - Installation Instructions



NOTICE

The H2hOme pump assembly can be removed for transporting and servicing the unit.

Pump Assembly Removal Instructions:



Remove the bolts on both sides of base plate.

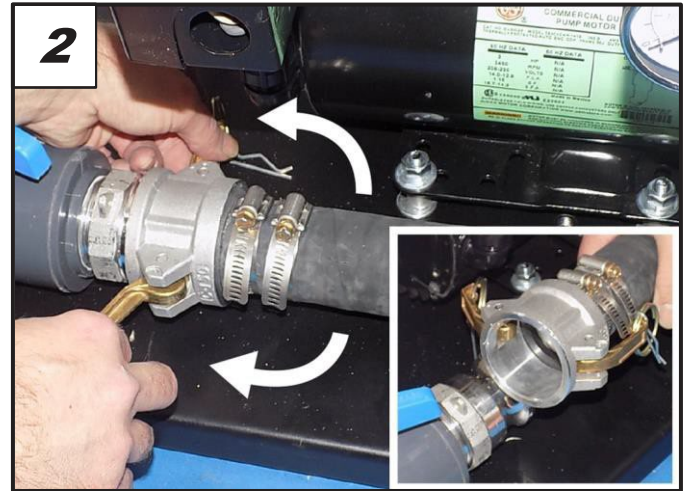

Loosen clamps on cam fitting & disconnect hose.

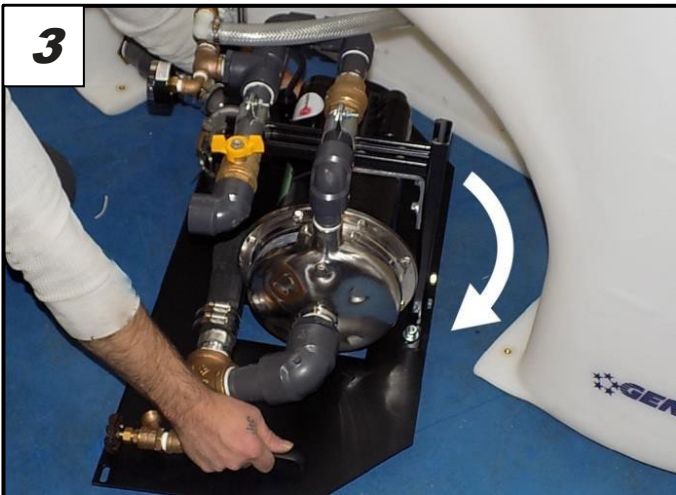

Slide the right side of pump assembly out first using the handles on the sides of the base plate.

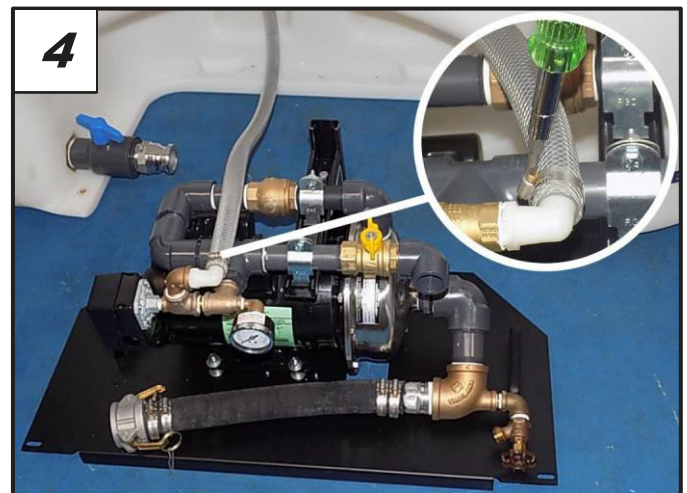

Continue to pull the pump assembly out by the base plate handles & disconnect the test hose.

3.4 Piping

Riser Installation Instructions:

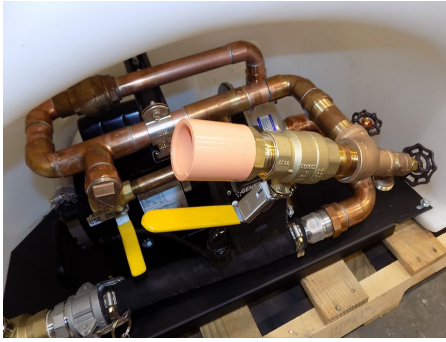

Thread the riser into manifold and tighten until riser is in an upright position.



NOTICE

All fluid piping practices should be in accordance with local codes. The systems are constructed using non-ferrous piping. Whenever components made from different material are piped in a system, use dielectric isolation of the material to help prevent galvanic corrosion. All threaded pipe connections must be sealed.

Correct sizing of pipe is critical to assure proper operation. **The fire protection contractor is responsible for calculation of the piping system attached to this system.** Once all piping and accessory installation has been completed, the system is ready to leak test. Pressurize the system with water and check around each connection and joint for leaks.



NOTICE

Do not use the system pump to fill the fire system with the initial fill of water. Use the domestic water source to prime the system and tank.



NOTICE

Riser MUST be properly supported or braced before startup

3.4 Piping (Cont'd)
H2hOme System Water Inlet Connection Diagram

Top Mount Inlet Connection (Autofill Connection)

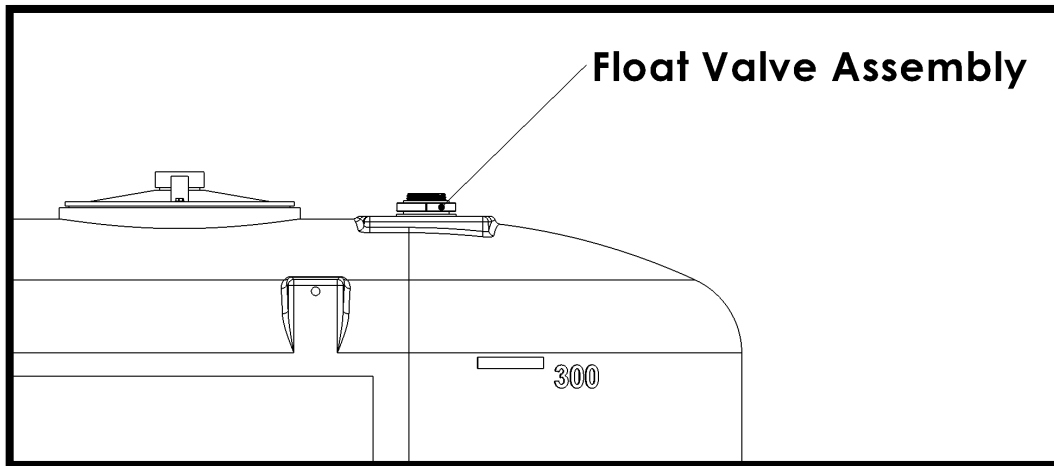

No pipe dope allowed on piping from water supply to fill valve connection. WARRANTY VOID if pipe dope is used on fill supply line.



If using copper piping, all soldering must be done away from the plastic tank and bulkhead.



Pressure reducing valve must be used if pressure at the inlet of the auto fill is greater than 70 PSI.



Install a 'backflow prevention device' upstream of the autofill to protect supply water from possible contamination.



Debris, pipe sealant, and other contaminants entering the auto-fill valve will cause the valve to malfunction. Run water through supply line until it runs clear before connecting to fill connection on tank. This will help ensure debris does not enter the auto-fill valve.

Overflow Piping Instructions:

Minimize vertical piping to overflow bulkhead



WARRANTY VOID if overflow is not piped to a drain.

Section 4 - System Testing & Training



NOTICE

Periodic testing of the system is required. We recommend a fire sprinkler system run test be performed monthly. This run test should be conducted annually at a minimum to ensure the fire sprinkler system is operating correctly.

For Testing Requirements and Training Information, consult your installation company.



WARNING

The test connection between the pump discharge and the top of the tank is for testing the pump circulation. Never connect the discharge test connection to the pump inlet. This will cause excessive heat and damage to the system.



WARNING

Rapid turning on and off (short cycling) of the pump must be avoided. Short or rapid cycling of the fire/water pump is an indication there is a system leak present that should be corrected/fixe immediately. Short or rapid cycling can cause damage to the fire/water pump making the system inoperable if not corrected.

Section 5 - Filling the Sprinkler System



NOTICE

Fill system using domestic water supply. Do not use pump and tank for initial fill of the sprinkler system.

Instructions for filling fire sprinkler system:

(DO NOT use pump for initial fill of sprinkler system)

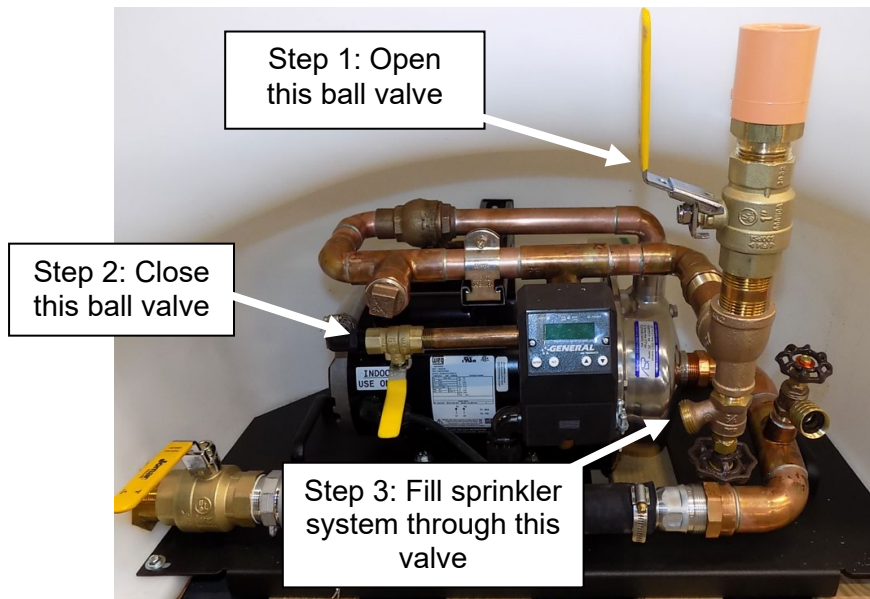

NOTICE

System is full when all air is expelled from the test connection. No air is to remain in system before energizing pump or damage to the pump can occur.

Section 6 - Start-Up Checklist

Pump Assembly Components:

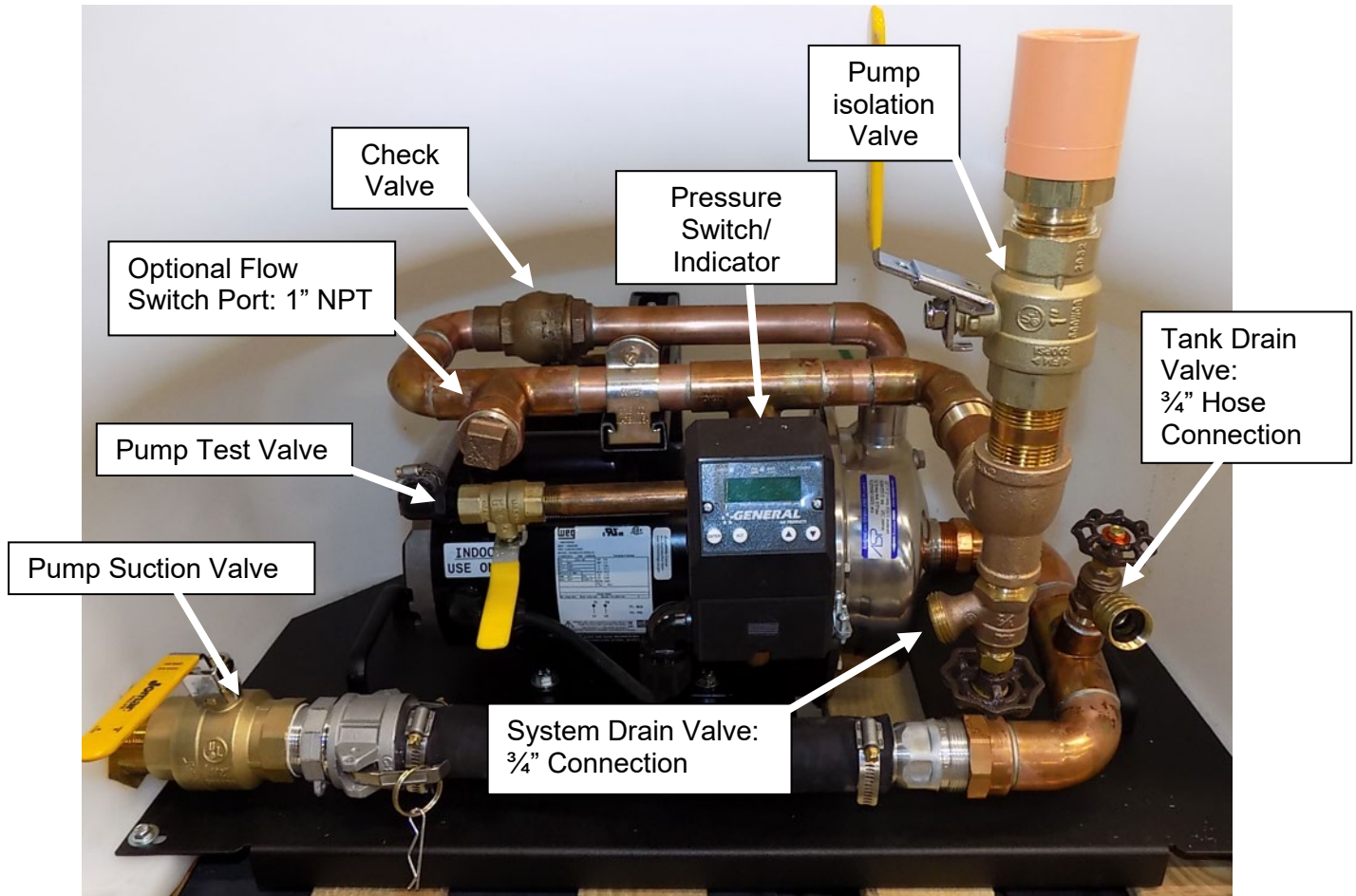

H2hOme System Start-up Checklist:

- 1.) Check that motor is securely fastened to the base plate.
- 2.) Connect sprinkler piping to 'Riser' connection on pump piping.
Note: sprinkler piping must be independently supported and not impart stress to unit piping
- 3.) Wire power to system
- 4.) Ensure correct voltage is applied. See product label for voltage of system.
Note: do not run pump dry
- 5.) Fill the tank with water.
- 6.) Pump start-up instructions:
 - 6a.) Open the following valves: Pump suction valve, pump test valve, pump isolation valve, and sprinkler system inspector test valve. Do not power pump yet.
 - 6b.) The pump is supplied with a hex bolt on the housing (see below) that allows the pump casing to be vented. Loosen the hex bolt to allow air to escape. Once the pump casing is filled with water, tighten the hex bolt. If the pump does not have a hex bolt, ignore this step

Section 6 - Start-Up Checklist

Stainless Steel Pump

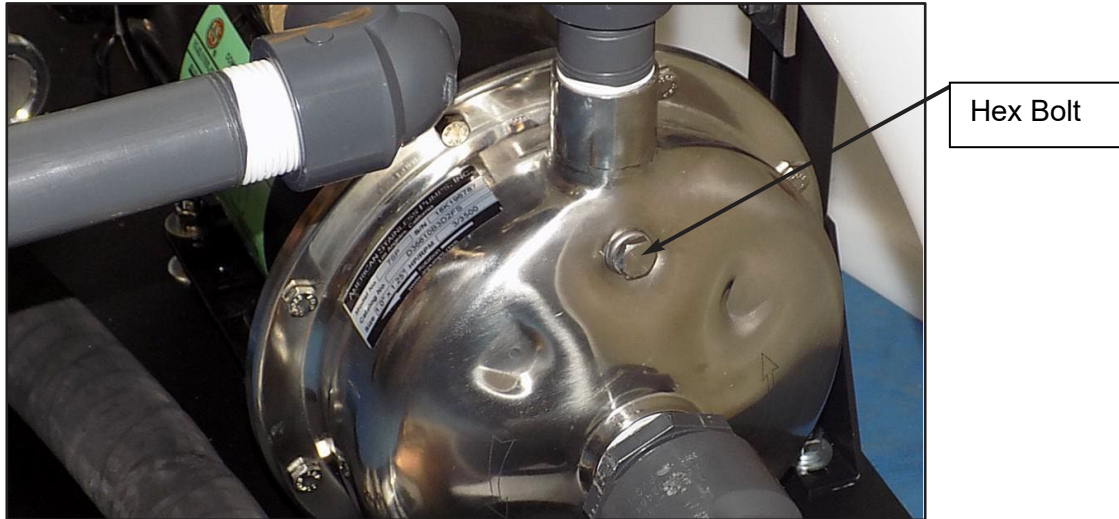

6c.) Turn power on to the pump Note: if pump starts rapidly turning 'on' and 'off' repeatedly immediately shut power to pump off or damage to pump may occur. Then call 800-345-8207

6d.) Close inspector test valve when steady stream of water is achieved

6e.) Close pump test valve last: Ball valve must go from "open position" to "Fully closed position" in one quick motion or pump will short cycle (rapidly turning 'on' and 'off' repeatedly) and damage may occur to pump



Closed position: ball valve and handle form a "T" shape



Open position: ball valve and handle form an "I" shape

- 7.) Check the tank and piping connections for leaks.
- 8.) Test unit in accordance with local procedures.
- 9.) Ensure all valves are in their correct open or closed normal operating position. Reference IOM Manual for correct valve positions.
- 10.) Post warning signs as required by local codes.

Section 7 – Wiring Diagrams

7.1 Wiring Diagram for D0 electrical option

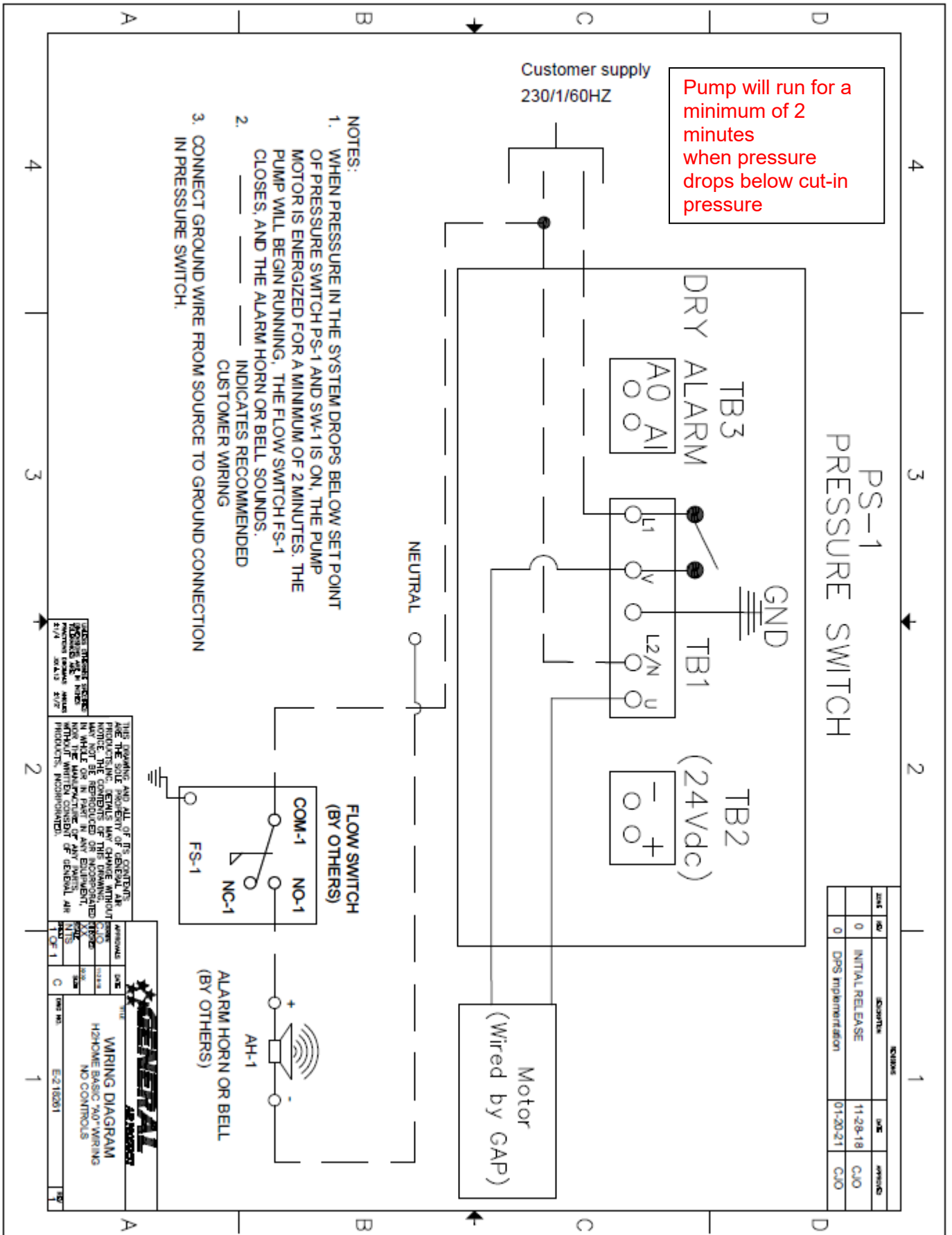

Section 7 – Wiring Diagrams

7.1 Wiring Diagram for D0 electrical option

Digital Pressure Switch (DPS)

230Vac Diagram

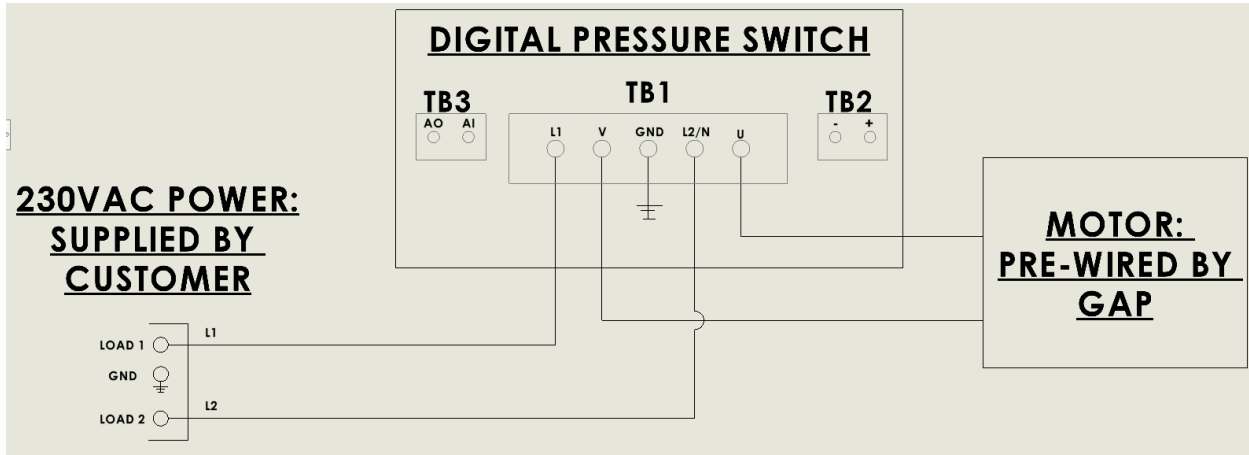

Pump will run for a minimum of 2 minutes when pressure drops below cut-in pressure

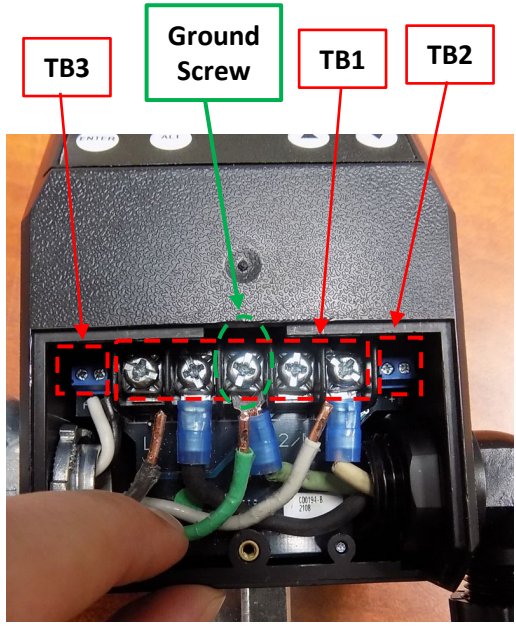
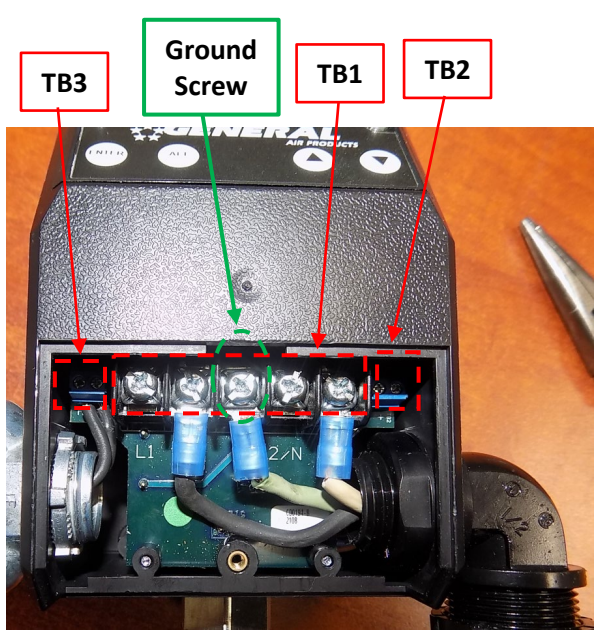

Section 7 – Wiring Diagrams

7.1 Alarm Wiring Diagram: Dry Contact alarm wiring

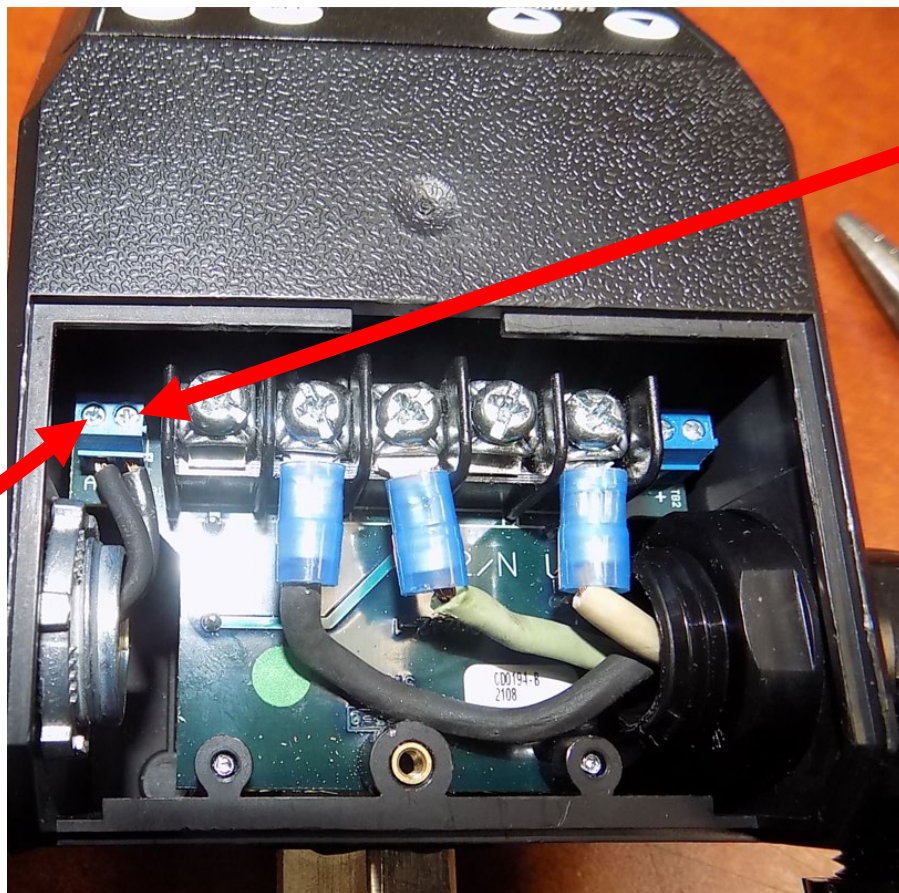
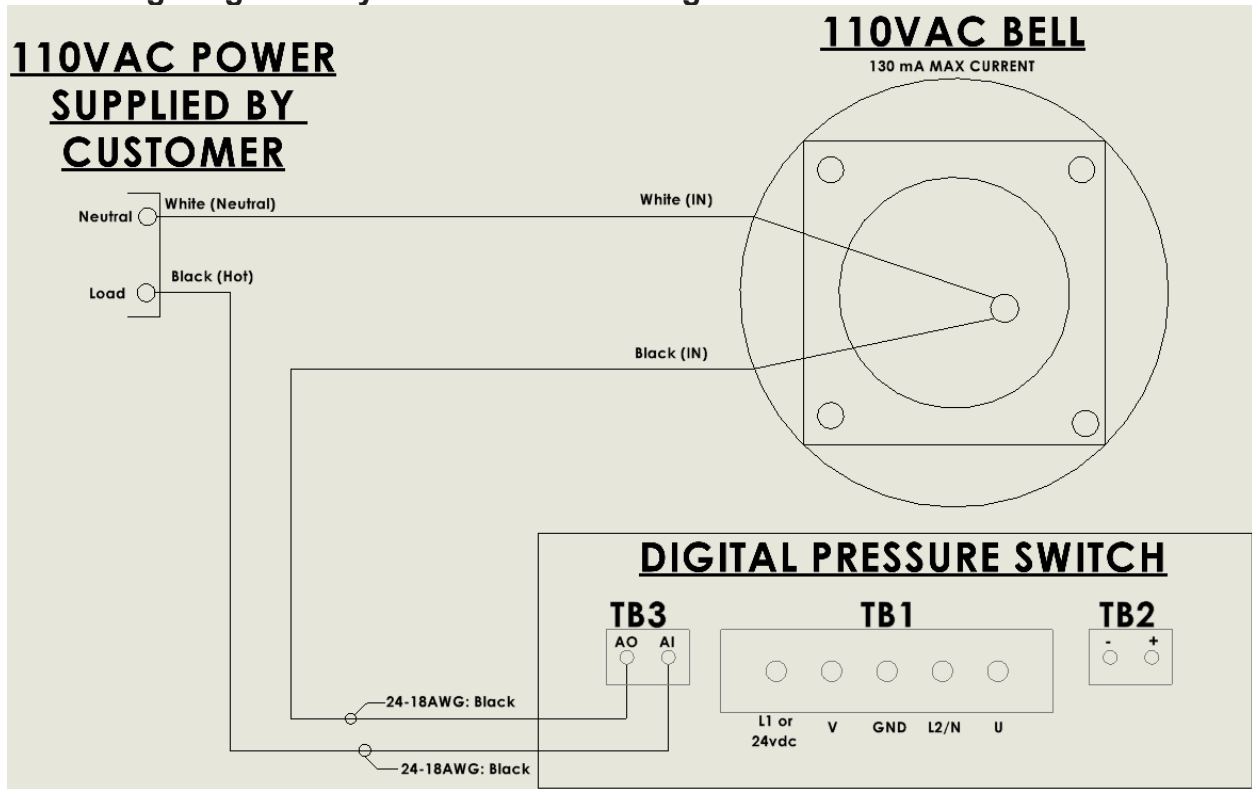

**TB3:
A0**

**TB3:
A1**

Section 8 – General Arrangement Drawing
General Arrangement

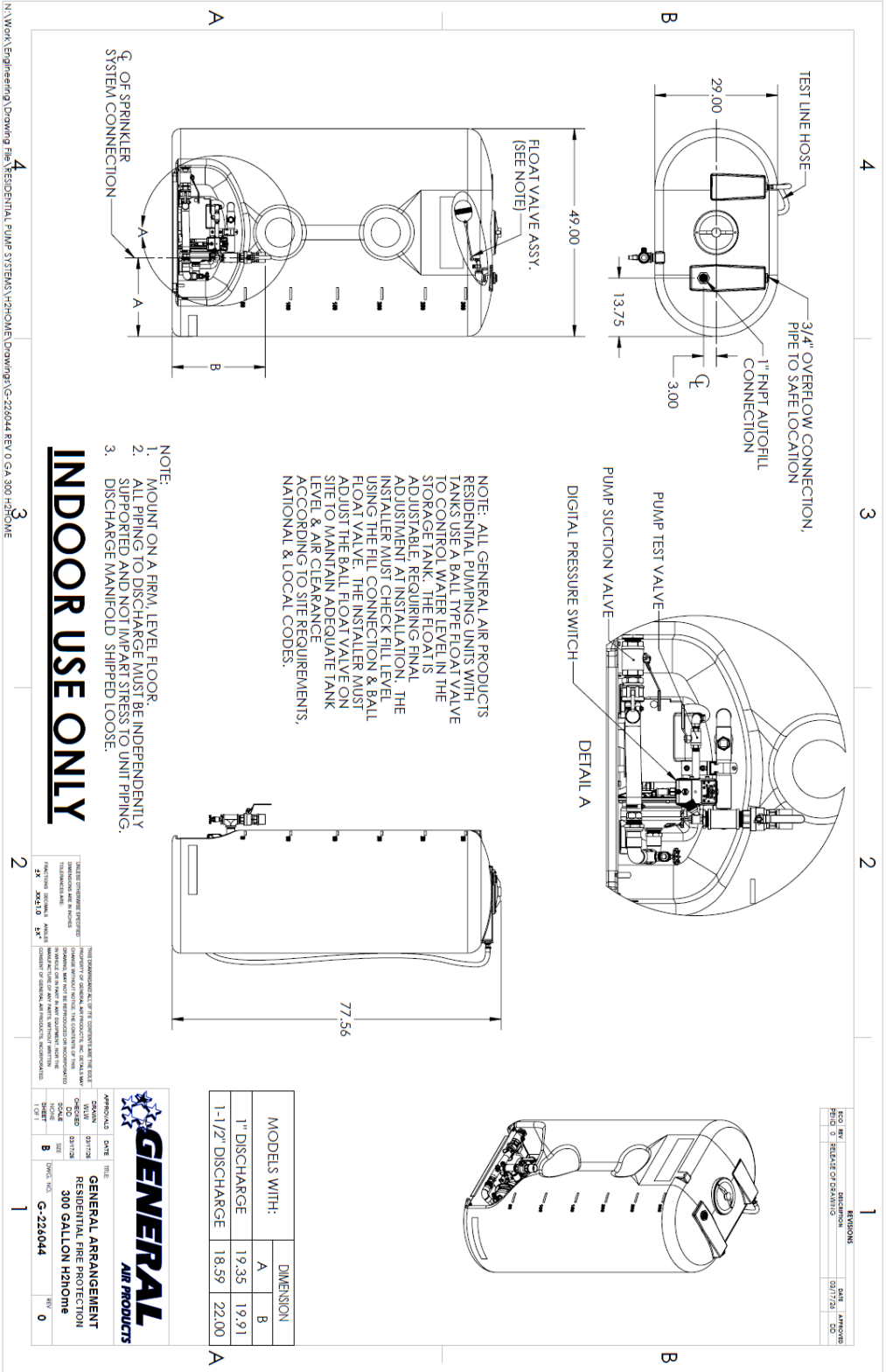

N:\Work\Engineering\Drawing File\RESIDENTIAL PUMP SYSTEMS\H2HOME\Drawing\G-224044 REV. 0 GA 300 H2HOME

Section 9 – Troubleshooting

Symptom	Possible Cause(s)	Corrective Action
Motor hums and runs slowly or not at all.	<ol style="list-style-type: none"> 1. Low or no voltage 2. Shortened or open motor winding 3. Defective pressure switch - contacts will not close 	<ol style="list-style-type: none"> 1. Check voltage during start. Voltage must be within +/- 10% of nominal voltage to start motor. Increase wire size if necessary to lower voltage drop. 2. Replace motor 3. Repair or replace pressure switch
Pump will not stop running	<ol style="list-style-type: none"> 1. 2-minute minimum run time function engaged (Digital pressure switch) 2. Insufficient voltage to motor 3. Pressure switch set too high 4. Piping too restrictive 5. Power hooked directly into motor or on the 'motor' contacts of pressure switch 	<ol style="list-style-type: none"> 1. Turn system on and wait two minutes to see if pump turns off 2. Check voltage during start. Voltage must be within +/- 10% of nominal voltage to start motor. Increase wire size if necessary to lower voltage drop. 3. Consult factory, adjust or replace 4. Add receiver vessel or increase pipe volume after compressor 5. Rewire to have incoming power into the 'line' contacts of pressure switch
Unit short cycles repeatedly	<ol style="list-style-type: none"> 1. Air pockets in sprinkler piping 2. Piping too restrictive 3. Check Valve has debris stuck in it 	<ol style="list-style-type: none"> 1. Prime sprinkler piping with domestic water source or use digit pressure switch 2. Add pressure relief valve downstream of the check valve 3. Repair or replace the check valve
Pump creates too much pressure	<ol style="list-style-type: none"> 1. 2-minute minimum run time function engaged: Digital pressure switch 2. Cut-out pressure set over pump deadhead (churn pressure): mechanical pressure switch 	<ol style="list-style-type: none"> 1. Install pressure relief valve and line -or replace Digital switch with mechanical switch 2. Consult factory
Alarm on Digital pressure switch display	<ol style="list-style-type: none"> 1. 'AL 4' Alarm but system is at required pressure 2. All other alarms 	<ol style="list-style-type: none"> 1. Hold "Enter" button for 3 seconds to clear 2. Consult factory for instructions

Pump Test

To initiate a pump test, simply hold the UP and DOWN arrow buttons for 3 seconds.



During a pump test, the pump will run for 15 seconds. After 10 seconds of runtime, the low-pressure alarm, AL 4, will turn on.

To reset the alarm, hold the "Enter" button for 3 seconds.

Section 10 - Warranty Policy

GENERAL PROVISIONS & LIMITATIONS

General Air Products, Inc. (the "Company") warrants to each original purchaser ("Purchaser") of its new products from the Company or its Authorized Distributor that such products are, at the time of delivery to the Purchaser, made with good materials and workmanship. No warranty is made with respect to:

1. Any product, which has been repaired or altered in such a way, in the Companies judgment, as to affect the product adversely.
2. Any product, which has, in the Companies judgment been subjected to negligence, accident, improper storage, improper installation or application.
3. Any product, which has not been operated or maintained in accordance with the recommendations of the Company.
4. Components or accessories manufactured, warranted and serviced by others.
5. Any reconditioned or prior owned product.

Claims for items described in 4. above should be submitted directly to the manufacturer.

WARRANTY PERIOD

The Company's obligation under this Warranty is limited to repair or, at its option, replacing during normal business hours at the designated facility of the Company, any part that in its judgment proved not to be as warranted within the applicable Warranty Period as follows.

COMPONENTS

All non-consumable components are warranted for 12 months from the date of purchase. Consumables are not covered under warranty. The unit must have been installed by either a factory authorized distributor or agent in accordance with the factory recommendations taking into account all other local site conditions not originally noted to the factory. The unit must be operated and maintained in accordance with the Factory recommendations and original design conditions. Failure to provide such proof of the above may void warranty.

LABOR TRANSPORTATION & INSPECTION

The Company will repair or replace any product or part thereof which in the Companies judgment is proved to be not as warranted. Labor costs are not covered under warranty.

All costs of transportation of product, labor or parts claimed not to be as warranted and, of repaired or replaced parts to or from factory shall be borne by purchaser. The Company may require the return of any part claimed not to be as warranted to one of its facilities as designated by the Company, transportation prepaid by Purchaser, to establish a claim under this warranty.

Replacement parts provided under the terms of the warranty are warranted for the remainder of the Warranty Period of the product upon which installed to the same extent as if such parts were original components.

DISCLAIMER

THE FOREGOING WARRANTY IS EXCLUSIVE AND IT IS EXPRESSLY AGREED THAT, EXCEPT AS TO TITLE, THE COMPANY MAKES NO OTHER WARRANTIES, EXPRESSED OR IMPLIED OR STATUTORY, INCLUDING ANY IMPLIED WARRANTY OR MERCHANTABILITY.

THE REMEDY PROVIDED UNDER THIS WARRANTY SHALL BE THE SOLE, EXCLUSIVE AND ONLY REMEDY AVAILABLE TO THE PURCHASER AND IN NO CASE SHALL THE COMPANY BE SUBJECT TO ANY OTHER OBLIGATIONS OR LIABILITIES. UNDER NO CIRCUMSTANCES SHALL THE COMPANY BE LIABLE FOR SPECIAL, INDIRECT, INCIDENTAL OR CONSEQUENTIAL DAMAGES, EXPENSES, LOSSES OR DELAYS HOWSOEVER CAUSED.

No statement, representation, agreement, or understanding, oral or written, made by any agent, distributor, representative or employee of the Company which is not contained in this Warranty will be binding upon the company unless made in writing and executed by an officer of the Company.

This warranty shall not be effective as to any claim which is not presented within 30 days after the date upon which the product is claimed not to have been as warranted. Any action for breach of this warranty must be commenced within one year after the date upon which the cause of action occurred.

Any adjustment made pursuant to this warranty shall not be construed as an admission by the Company that any product was not as warranted.

PROMPT DISPOSITION & RETURNS POLICY

The Company will make a good faith effort for prompt correction or other adjustment with respect to any product, which proves to be defective within the warranty period. Before returning any product, write or call the distributor, agent or authorized company from which the product was purchased, describing defect and giving date and number of original invoice, a well as proof of Factory supplied consumables and proof of scheduled maintenance. No products will be accepted for return without the Company issuing a "Returned Goods Authorization" (RGA) to the Purchaser and unless accompanied by a properly authorized RGA request form initiated by the Purchaser. Return freight must be prepaid and each returned product must have the RGA number clearly marked on the product. Title and risk of loss pass to buyer upon delivery to the common carrier.

PRODUCT SUITABILITY

Many States, Localities and Countries have codes and regulations governing sales, construction, installation, and/or use of products for certain purposes, which may vary from those in neighboring areas. While General Air Products, Inc. attempts to assure that its products comply with such codes, it cannot guarantee compliance, and cannot be responsible for how the product is installed or used? Before purchase and use of a product, please review the product application, and national and local codes and regulations, and be sure that the product, installation, and use will comply with them.

